

**LECTURE NOTES  
ON**

**MOBILE COMPUTING**

**IV B. Tech I semester  
(JNTU)**

JNTU World

# Unit-1

## Introduction to Mobile Computing

The rapidly expanding technology of cellular communication, wireless LANs, and satellite services will make information accessible anywhere and at any time. Regardless of size, most mobile computers will be equipped with a wireless connection to the fixed part of the network, and, perhaps, to other mobile computers. The resulting computing environment, which is often referred to as mobile or nomadic computing, no longer requires users to maintain a fixed and universally known position in the network and enables almost unrestricted mobility. Mobility and portability will create an entire new class of applications and, possibly, new massive markets combining personal computing and consumer electronics.

- Mobile Computing is an umbrella term used to describe technologies that enable people to access network services anyplace, anytime, and anywhere.

A communication device can exhibit any one of the following characteristics:

- **Fixed and wired:** This configuration describes the typical desktop computer in an office. Neither weight nor power consumption of the devices allow for mobile usage. The devices use fixed networks for performance reasons.
- **Mobile and wired:** Many of today's laptops fall into this category; users carry the laptop from one hotel to the next, reconnecting to the company's network via the telephone network and a modem.
- **Fixed and wireless:** This mode is used for installing networks, e.g., in historical buildings to avoid damage by installing wires, or at trade shows to ensure fast network setup.
- **Mobile and wireless:** This is the most interesting case. No cable restricts the user, who can roam between different wireless networks. Most technologies discussed in this book deal with this type of device and the networks supporting them. Today's most successful example for this category is GSM with more than 800 million users.

## APPLICATIONS OF MOBILE COMPUTING

In many fields of work, the ability to keep on the move is vital in order to utilise time efficiently. The importance of Mobile Computers has been highlighted in many fields of which a few are described below:

- a. **Vehicles:** Music, news, road conditions, weather reports, and other broadcast information are received via digital audio broadcasting (DAB) with 1.5 Mbit/s. For personal communication, a universal mobile telecommunications system (UMTS) phone might be available offering voice and data connectivity with 384 kbit/s. The current position of the car is determined via the global positioning system (GPS). Cars driving in the same area build a local ad-hoc network for the fast exchange of information in emergency situations or to help each other keep a safe distance. In case of an accident, not only will the airbag be triggered, but the police and ambulance service will be informed via an emergency call to a service provider. Buses, trucks, and trains are already transmitting maintenance and logistic information to their home base, which helps to improve organization (fleet management), and saves time and money.
- b. **Emergencies:** An ambulance with a high-quality wireless connection to a hospital can carry vital information about injured persons to the hospital from the scene of the accident. All the necessary steps for this particular type of accident can be prepared and specialists can be consulted for an early diagnosis. Wireless networks are the only means of communication in the case of natural disasters such as hurricanes or earthquakes. In the worst cases, only decentralized, wireless ad-hoc networks survive.
- c. **Business:** Managers can use mobile computers say, critical presentations to major customers. They can access the latest market share information. At a small recess, they can revise the presentation to take advantage of this information. They can communicate with the office about possible new offers and call meetings for discussing responds to the new proposals. Therefore, mobile computers can leverage competitive advantages. A travelling salesman today needs instant access to the company's database: to ensure that files on his or her laptop reflect the current situation, to enable the company to keep track of all activities of their travelling employees, to keep databases consistent etc. With wireless access, the laptop can be turned into a true mobile office, but efficient and powerful synchronization mechanisms are needed to ensure data consistency.

- d. **Credit Card Verification**: At Point of Sale (POS) terminals in shops and supermarkets, when customers use credit cards for transactions, the intercommunication required between the bank central computer and the POS terminal, in order to effect verification of the card usage, can take place quickly and securely over cellular channels using a mobile computer unit. This can speed up the transaction process and relieve congestion at the POS terminals.
- e. **Replacement of Wired Networks**: wireless networks can also be used to replace wired networks, e.g., remote sensors, for tradeshows, or in historic buildings. Due to economic reasons, it is often impossible to wire remote sensors for weather forecasts, earthquake detection, or to provide environmental information. Wireless connections, e.g., via satellite, can help in this situation. Other examples for wireless networks are computers, sensors, or information displays in historical buildings, where excess cabling may destroy valuable walls or floors.
- f. **Infotainment**: wireless networks can provide up-to-date information at any appropriate location. The travel guide might tell you something about the history of a building (knowing via GPS, contact to a local base station, or triangulation where you are) downloading information about a concert in the building at the same evening via a local wireless network. Another growing field of wireless network applications lies in entertainment and games to enable, e.g., ad-hoc gaming networks as soon as people meet to play together.

### Limitations of Mobile Computing

- Resource constraints: Battery
- Interference: Radio transmission cannot be protected against interference using shielding and result in higher loss rates for transmitted data or higher bit error rates respectively
- Bandwidth: Although they are continuously increasing, transmission rates are still very low for wireless devices compared to desktop systems. Researchers look for more efficient communication protocols with low overhead.
- Dynamic changes in communication environment: variations in signal power within a region, thus link delays and connection losses
- Network Issues: discovery of the connection-service to destination and connection stability
- Interoperability issues: the varying protocol standards

- Security constraints: Not only can portable devices be stolen more easily, but the radio interface is also prone to the dangers of eavesdropping. Wireless access must always include encryption, authentication, and other security mechanisms that must be efficient and simple to use.

### A simplified reference model

The figure shows the **protocol stack** implemented in the system according to the reference model. **End-systems**, such as the PDA and computer in the example, need a full protocol stack comprising the application layer, transport layer, network layer, data link layer, and physical layer. Applications on the end-systems communicate with each other using the lower layer services. **Intermediate systems**, such as the interworking unit, do not necessarily need all of the layers.

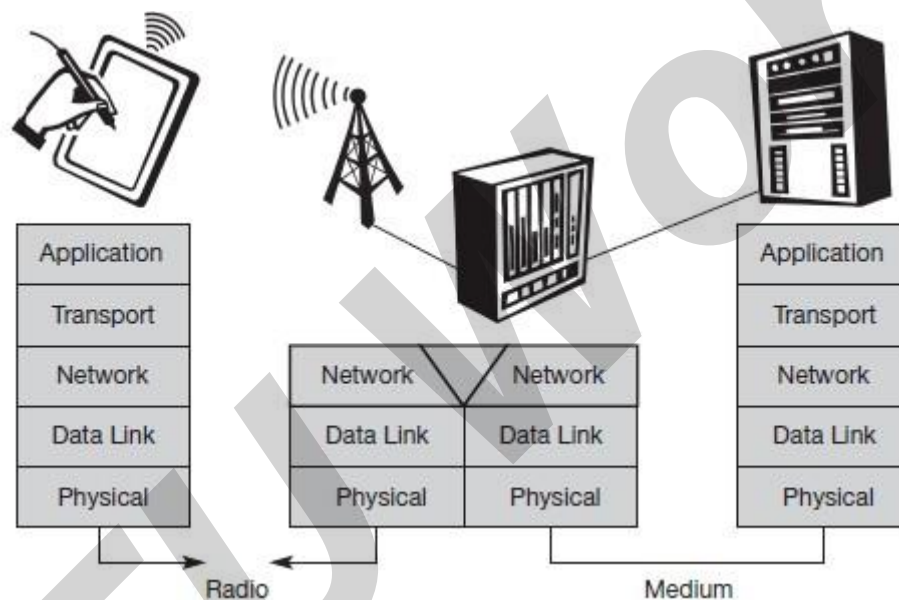

**A Simplified Reference Model**

- **Physical layer:** This is the lowest layer in a communication system and is responsible for the conversion of a stream of bits into signals that can be transmitted on the sender side. The physical layer of the receiver then transforms the signals back into a bit stream. For wireless communication, the physical layer is responsible for frequency selection, generation of the carrier frequency, signal detection (although heavy interference may disturb the signal), modulation of data onto a carrier frequency and (depending on the transmission scheme) encryption.

- **Data link layer:** The main tasks of this layer include accessing the medium, multiplexing of different data streams, correction of transmission errors, and synchronization (i.e., detection of a data frame). Altogether, the data link layer is responsible for a reliable point-to-point

connection between two devices or a point-to-multipoint connection between one sender and several receivers.

- **Network layer:** This third layer is responsible for routing packets through a network or establishing a connection between two entities over many other intermediate systems. Important functions are addressing, routing, device location, and handover between different networks.
- **Transport layer:** This layer is used in the reference model to establish an end-to-end connection
- **Application layer:** Finally, the applications (complemented by additional layers that can support applications) are situated on top of all transmission oriented layers. Functions are service location, support for multimedia applications, adaptive applications that can handle the large variations in transmission characteristics, and wireless access to the world-wide web using a portable device.

### GSM : Mobile services, System architecture, Radio interface, Protocols, Localization and calling, Handover, Security, and New data services.

#### **GSM Services**

GSM is the most successful digital mobile telecommunication system in the world today. It is used by over 800 million people in more than 190 countries. GSM permits the integration of different voice and data services and the interworking with existing networks. Services make a network interesting for customers. GSM has defined three different categories of services: **bearer, tele and supplementary services.**

**Bearer services:** GSM specifies different mechanisms for data transmission, the original GSM allowing for data rates of up to 9600 bit/s for non-voice services. Bearer services permit transparent and non-transparent, synchronous or asynchronous data transmission. **Transparent bearer services** only use the functions of the physical layer (layer 1) to transmit data. Data transmission has a constant delay and throughput if no transmission errors occur. Transmission quality can be improved with the use of **forward error correction (FEC)**, which codes redundancy into the data stream and helps to reconstruct the original data in case of transmission errors. Transparent bearer services do not try to recover lost data in case of, for example, shadowing or interruptions due to handover. **Non-transparent bearer services** use protocols of layers two and three to implement error correction and flow control. These services use the transparent bearer services, adding a **radio link protocol (RLP)**. This protocol comprises mechanisms of **high-level data link control (HDLC)**, and special selective-reject mechanisms to trigger retransmission of erroneous data.

Using transparent and non-transparent services, GSM specifies several bearer services for interworking with PSTN, ISDN, and packet switched public data networks (PSPDN) like X.25, which is available worldwide. Data transmission can be full-duplex, synchronous with data rates of 1.2, 2.4, 4.8, and 9.6 kbit/s or full-duplex, asynchronous from 300 to 9,600 bit/s.

**Tele services:** GSM mainly focuses on voice-oriented tele services. These comprise encrypted voice transmission, message services, and basic data communication with terminals as known from the PSTN or ISDN (e.g., fax). The primary goal of GSM was the provision of high-quality digital voice transmission. Special codecs (coder/decoder) are used for voice transmission, while other codecs are used for the transmission of analog data for communication with traditional computer modems used in, e.g., fax machines. Another service offered by GSM is the **emergency number** (eg 911, 999). This service is mandatory for all providers and free of charge. This connection also has the highest priority, possibly pre-empting other connections, and will automatically be set up with the closest emergency center. A useful service for very simple message transfer is the **short message service (SMS)**, which offers transmission of messages of up to 160 characters. Sending and receiving of SMS is possible during data or voice transmission. It can be used for “serious” applications such as displaying road conditions, e-mail headers or stock quotes, but it can also transfer logos, ring tones, horoscopes and love letters.

The successor of SMS, the **enhanced message service (EMS)**, offers a larger message size, formatted text, and the transmission of animated pictures, small images and ring tones in a standardized way. But with MMS, EMS was hardly used. MMS offers the transmission of larger pictures (GIF, JPG, WBMP), short video clips etc. and comes with mobile phones that integrate small cameras. Another non-voice tele service is **group 3 fax**, which is available worldwide. In this service, fax data is transmitted as digital data over the analog telephone network according to the ITU-T standards T.4 and T.30 using modems.

**Supplementary services:** In addition to tele and bearer services, GSM providers can offer **supplementary services**. these services offer various enhancements for the standard telephony service, and may vary from provider to provider. Typical services are user **identification**, call **redirection**, or **forwarding** of ongoing calls, barring of incoming/outgoing calls, Advice of Charge (AoC) etc. Standard ISDN features such as **closed user groups** and **multiparty** communication may be available.

## GSM Architecture

A GSM system consists of three subsystems, the radio sub system (RSS), the network and switching subsystem (NSS), and the operation subsystem (OSS).

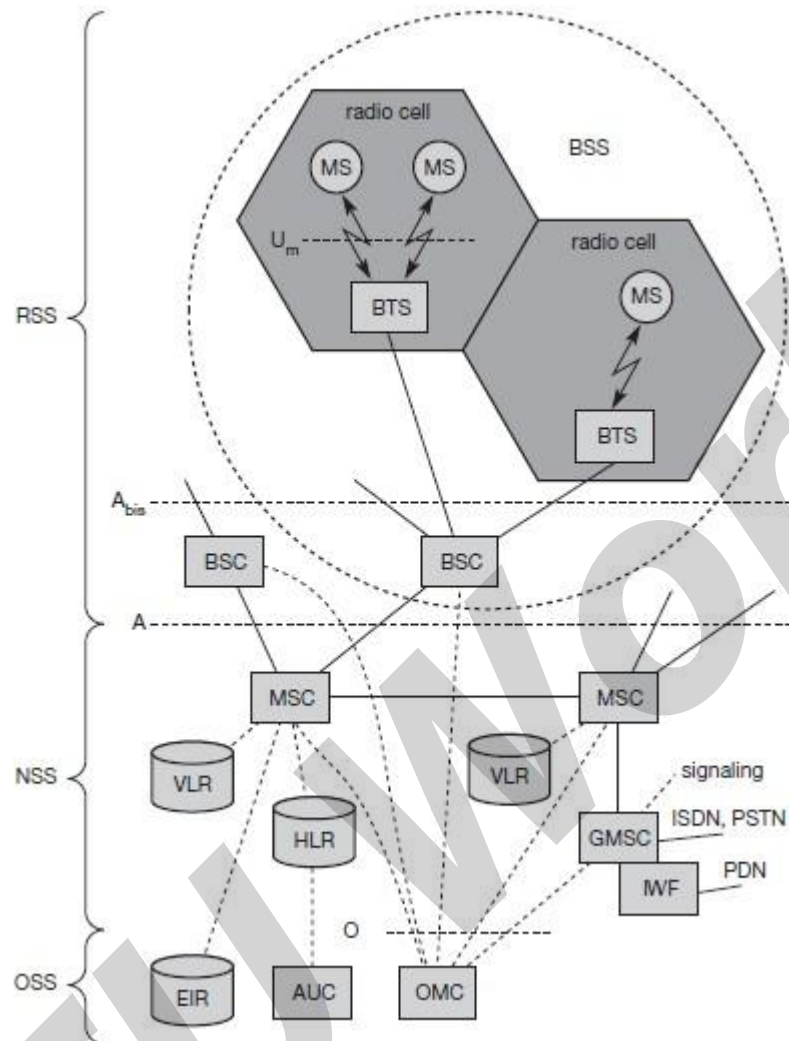

**Functional Architecture of a GSM System**

**Network Switching Subsystem:** The NSS is responsible for performing call processing and subscriber related functions. The switching system includes the following functional units:

- **Home location register (HLR):** It is a database used for storage and management of subscriptions. HLR stores permanent data about subscribers, including a subscribers service profile, location information and activity status. When an individual buys a subscription from the PCS provider, he or she is registered in the HLR of that operator.
- **Visitor location register (VLR):** It is a database that contains temporary information about subscribers that is needed by the MSC in order to service visiting subscribers. VLR is always integrated with the MSC. When a MS roams into a new MSC area, the VLR



connected to that MSC will request data about the mobile station from the HLR. Later if the mobile station needs to make a call, VLR will be having all the information needed for call setup.

- **Authentication center (AUC)**: A unit called the AUC provides authentication and encryption parameters that verify the users identity and ensure the confidentiality of each call.
- **Equipment identity register (EIR)**: It is a database that contains information about the identity of mobile equipment that prevents calls from stolen, unauthorized or defective mobile stations.
- **Mobile switching center (MSC)**: The MSC performs the telephony switching functions of the system. It controls calls to and from other telephone and data systems.

**Radio Subsystem (RSS)**: the **radio subsystem (RSS)** comprises all radio specific entities, i.e., the **mobile stations (MS)** and the **base station subsystem (BSS)**. The figure shows the connection between the RSS and the NSS via the **A interface** (solid lines) and the connection to the OSS via the **O interface** (dashed lines).

- **Base station subsystem (BSS)**: A GSM network comprises many BSSs, each controlled by a base station controller (BSC). The BSS performs all functions necessary to maintain radio connections to an MS, coding/decoding of voice, and rate adaptation to/from the wireless network part. Besides a BSC, the BSS contains several BTSs.
- **Base station controllers (BSC)**: The BSC provides all the control functions and physical links between the MSC and BTS. It is a high capacity switch that provides functions such as handover, cell configuration data, and control of radio frequency (RF) power levels in BTS. A number of BSC's are served by and MSC.
- **Base transceiver station (BTS)**: The BTS handles the radio interface to the mobile station. A BTS can form a radio cell or, using sectorized antennas, several and is connected to MS via the **Um interface**, and to the BSC via the **Abis interface**. The Um interface contains all the mechanisms necessary for wireless transmission (TDMA, FDMA etc.)The BTS is the radio equipment (transceivers and antennas) needed to service each cell in the network. A group of BTS's are controlled by an BSC.

**Operation and Support system**: The operations and maintenance center (OMC) is connected to all equipment in the switching system and to the BSC. Implementation of OMC is called operation and support system (OSS). The OSS is the functional entity from which the network operator monitors and controls the system. The purpose of OSS is to offer the customer cost-effective support for centralized, regional and local operational and maintenance activities that are required for a GSM network. OSS provides a network overview and allows engineers to monitor, diagnose and troubleshoot every aspect of the GSM network.

The mobile station (MS) consists of the mobile equipment (the terminal) and a smart card called the Subscriber Identity Module (SIM). The SIM provides personal mobility, so that the user can have access to subscribed services irrespective of a specific terminal. By inserting the SIM card into another GSM terminal, the user is able to receive calls at that terminal, make calls from that terminal, and receive other subscribed services.

The mobile equipment is uniquely identified by the International Mobile Equipment Identity (IMEI). The SIM card contains the International Mobile Subscriber Identity (IMSI) used to identify the subscriber to the system, a secret key for authentication, and other information. The IMEI and the IMSI are independent, thereby allowing personal mobility. The SIM card may be protected against unauthorized use by a password or personal identity number.

## Radio Interface

The most interesting interface in a GSM system is Um, the radio interface, as it comprises various multiplexing and media access mechanisms. GSM implements SDMA using cells with BTS and assigns an MS to a BTS.

### GSM - TDMA/FDMA

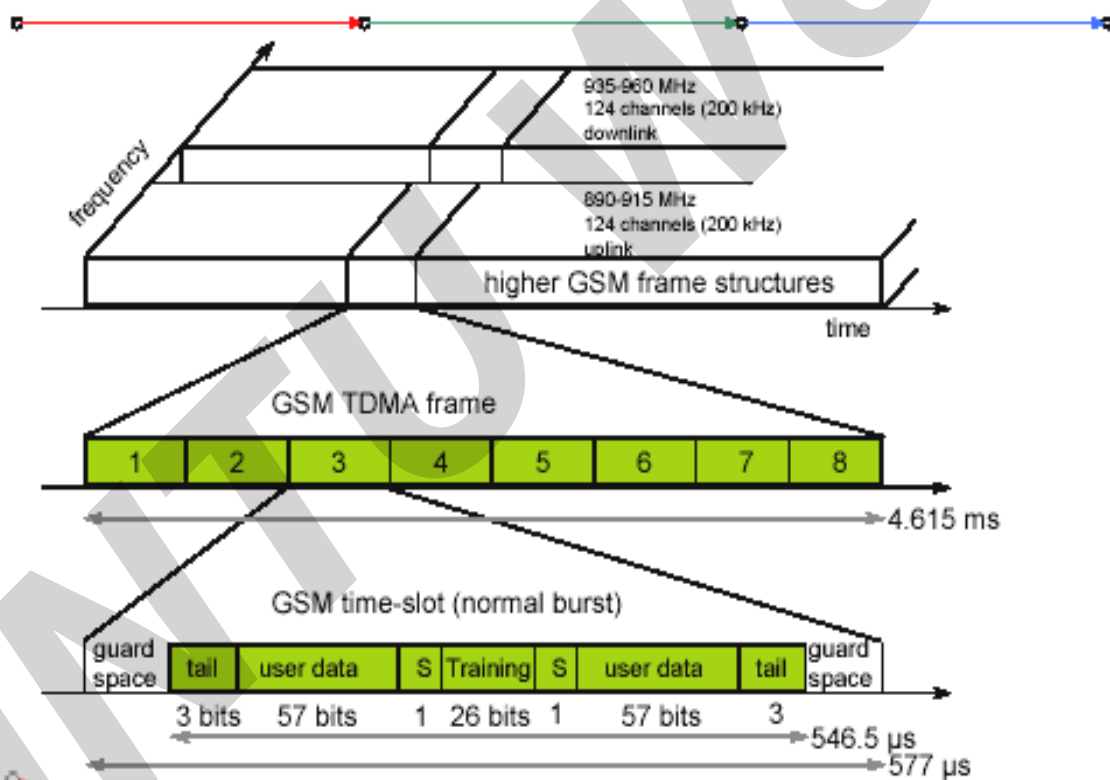

**GSM TDMA Frame, Slots and Bursts**

Each of the 248 channels is additionally separated in time via a **GSM TDMA frame**, i.e., each 200 kHz carrier is subdivided into frames that are repeated continuously. The duration of a frame is 4.615 ms. A frame is again subdivided into 8 **GSM time slots**, where each slot represents a physical TDM channel and lasts for 577  $\mu\text{s}$ . Each TDM channel occupies the 200 kHz carrier for 577  $\mu\text{s}$  every 4.615 ms. Data is transmitted in small portions, called **bursts**. The following figure shows a so called **normal burst** as used for data transmission inside a time slot. As shown, the burst is only 546.5  $\mu\text{s}$  long and contains 148 bits. The remaining 30.5  $\mu\text{s}$  are used as **guard space** to avoid overlapping with other bursts due to different path delays and to give the transmitter time to turn on and off.

The first and last three bits of a normal burst (**tail**) are all set to 0 and can be used to enhance the receiver performance. The **training** sequence in the middle of a slot is used to adapt the parameters of the receiver to the current path propagation characteristics and to select the strongest signal in case of multi-path propagation. A flag **S** indicates whether the **data** field contains user or network control data.

Apart from the normal burst, ETSI (1993a) defines four more bursts for data transmission: a **frequency correction** burst allows the MS to correct the local oscillator to avoid interference with neighbouring channels, a **synchronization burst** with an extended training sequence synchronizes the MS with the BTS in time, an **access burst** is used for the initial connection setup between MS and BTS, and finally a **dummy burst** is used if no data is available for a slot.

### Logical channels and frame hierarchy

Two types of channels, namely physical channels and logical channels are present. **Physical channel:** channel defined by specifying both, a carrier frequency and a TDMA timeslot number. **Logic channel:** logical channels are multiplexed into the physical channels. Each logic channel performs a specific task. Consequently the data of a logical channel is transmitted in the corresponding timeslots of the physical channel. During this process, logical channels can occupy a part of the physical channel or even the entire channel.

Each of the frequency carriers is divided into frames of 8 timeslots of approximately 577  $\mu\text{s}$  (15/26  $\mu\text{s}$ ) duration with 156.25 bits per timeslot. The duration of a TDMA frame is 4.615ms (577  $\mu\text{s}$  x 8 = 4.615 ms). The bits per timeslot and frame duration yield a gross bit rate of about 271kbps per TDMA frame.

TDMA frames are grouped into two types of multiframes:

- 26-frame multiframe (4.615ms x 26 = 120 ms) comprising of 26 TDMA frames. This multiframe is used to carry traffic channels and their associated control channels.

- 51-frame multiframe (4.615ms x 51 = 235.4 ms) comprising 51 TDMA frames.

This multiframe is exclusively used for control channels.

The multiframe structure is further multiplexed into a single superframe of duration of 6.12sec. This means a superframe consists of

- 51 multiframes of 26 frames.
- 26 multiframes of 51 frames.

The last multiplexing level of the frame hierarchy, consisting of 2048 superframes (2715648 TDMA frames), is a hyperframe. This long time period is needed to support the GSM data encryption mechanisms. The frame hierarchy is shown below:

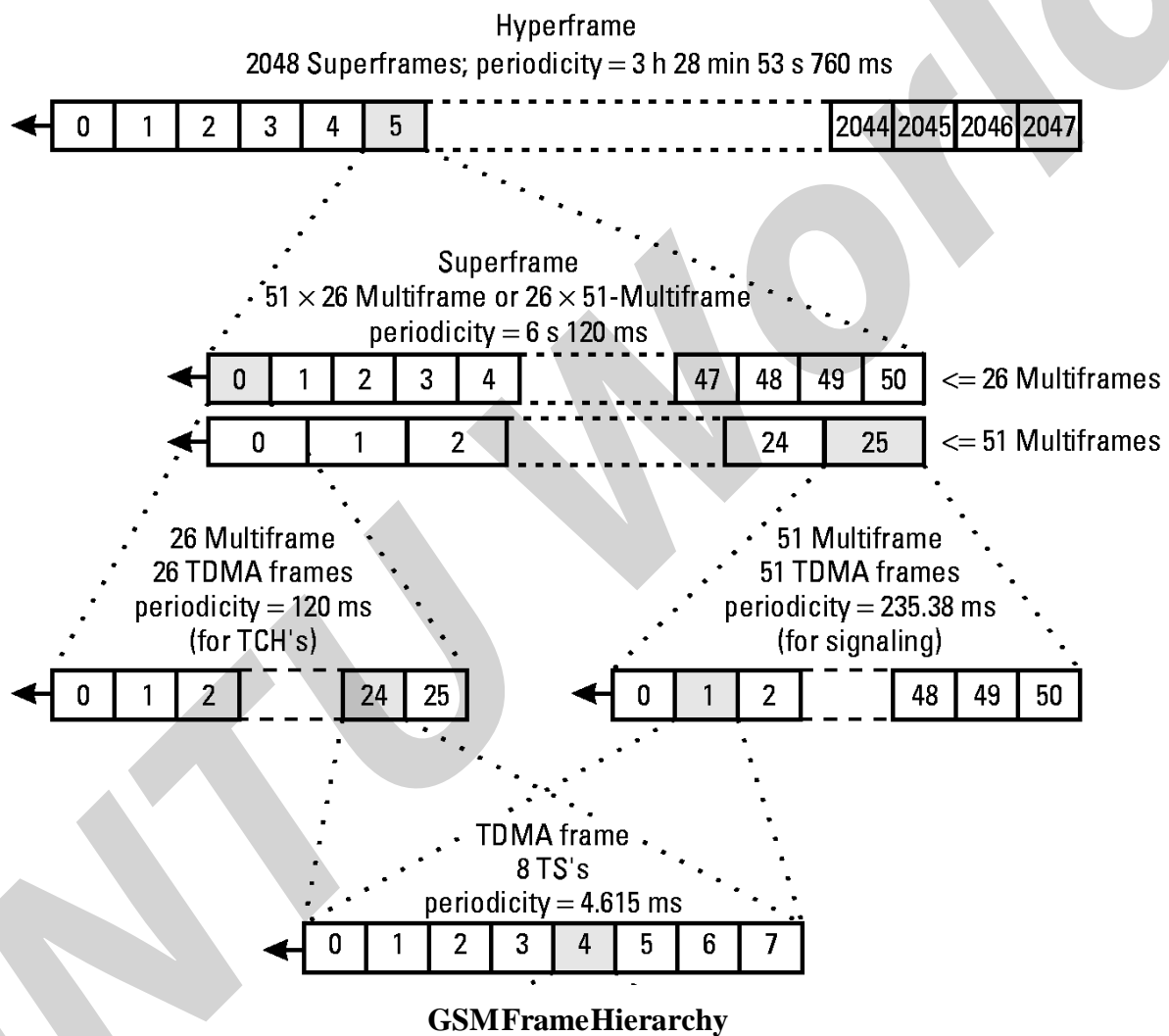

There are two different types of logical channel within the GSM system: Traffic channels (TCHs), Control channels (CCHs).

**Traffic Channels:** Traffic channels carry user information such as encoded speech or user data. Traffic channels are defined by using a 26-frame multiframe. Two general forms are defined:

- i. Full rate traffic channels (TCH/F), at a gross bit rate of 22.8 kbps (456bits / 20ms)
- ii. Half rate traffic channels (TCH/H), at a gross bit rate of 11.4 kbps.

Uplink and downlink are separated by three slots (bursts) in the 26-multiframe structure. This simplifies the duplexing function in mobile terminals design, as mobiles will not need to transmit and receive at the same time. The 26-frame multiframe structure, shown below multiplexes two types of logical channels, a TCH and a Slow Associated Control Channel (SACCH).

However, if required, a Fast Associated Control Channel (FACCH) can steal TCH in order to transmit control information at a higher bit rate. This is usually the case during the handover process. In total 24 TCH/F are transmitted and one SACCH.

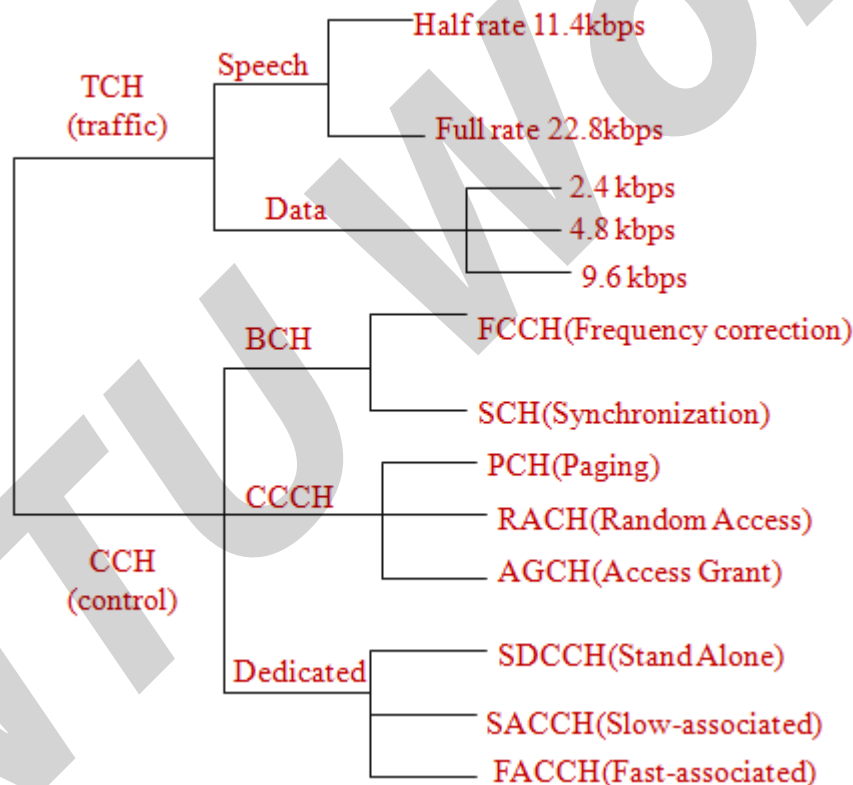

**Control Channels:** Control channels carry system signalling and synchronisation data for control procedures such as location registration, mobile station synchronisation, paging, random access etc. between base station and mobile station. Three categories of control channel are defined: Broadcast, Common and Dedicated. Control channels are multiplexed into the 51-frame multiframe.

- **Broadcast control channel (BCCH):** A BTS uses this channel to signal information to all MSs within a cell. Information transmitted in this channel is, e.g., the cell identifier, options available within this cell (frequency hopping), and frequencies available inside the cell and in neighboring cells. The BTS sends information for frequency correction via the **frequency correction channel (FCCH)** and information about time synchronization via the **synchronization channel (SCH)**, where both channels are subchannels of the BCCH.
- **Common control channel (CCCH):** All information regarding connection setup between MS and BS is exchanged via the CCCH. For calls toward an MS, the BTS uses the **paging channel (PCH)** for paging the appropriate MS. If an MS wants to set up a call, it uses the **random access channel (RACH)** to send data to the BTS. The RACH implements multiple access (all MSs within a cell may access this channel) using slotted Aloha. This is where a collision may occur with other MSs in a GSM system. The BTS uses the **access grant channel (AGCH)** to signal an MS that it can use a TCH or SDCCH for further connection setup.
- **Dedicated control channel (DCCH):** While the previous channels have all been unidirectional, the following channels are bidirectional. As long as an MS has not established a TCH with the BTS, it uses the **stand-alone dedicated control channel (SDCCH)** with a low data rate (782 bit/s) for signaling. This can comprise authentication, registration or other data needed for setting up a TCH. Each TCH and SDCCH has a **slow associated dedicated control channel (SACCH)** associated with it, which is used to exchange system information, such as the channel quality and signal power level. Finally, if more signaling information needs to be transmitted and a TCH already exists, GSM uses a **fast associated dedicated control channel (FACCH)**. The FACCH uses the time slots which are otherwise used by the TCH. This is necessary in the case of handovers where BTS and MS have to exchange larger amounts of data in less time.

## GSM Protocols

The signalling protocol in GSM is structured into three general layers depending on the interface, as shown below. Layer 1 is the physical layer that handles all **radio**-specific functions. This includes the creation of bursts according to the five different formats, **multiplexing** of bursts into a TDMA frame, **synchronization** with the BTS, detection of idle channels, and measurement of the **channel quality** on the downlink. The physical layer at Um uses GMSK for digital **modulation** and performs **encryption/decryption** of data, i.e., encryption is not performed end-to-end, but only between MS and BSS over the air interface.

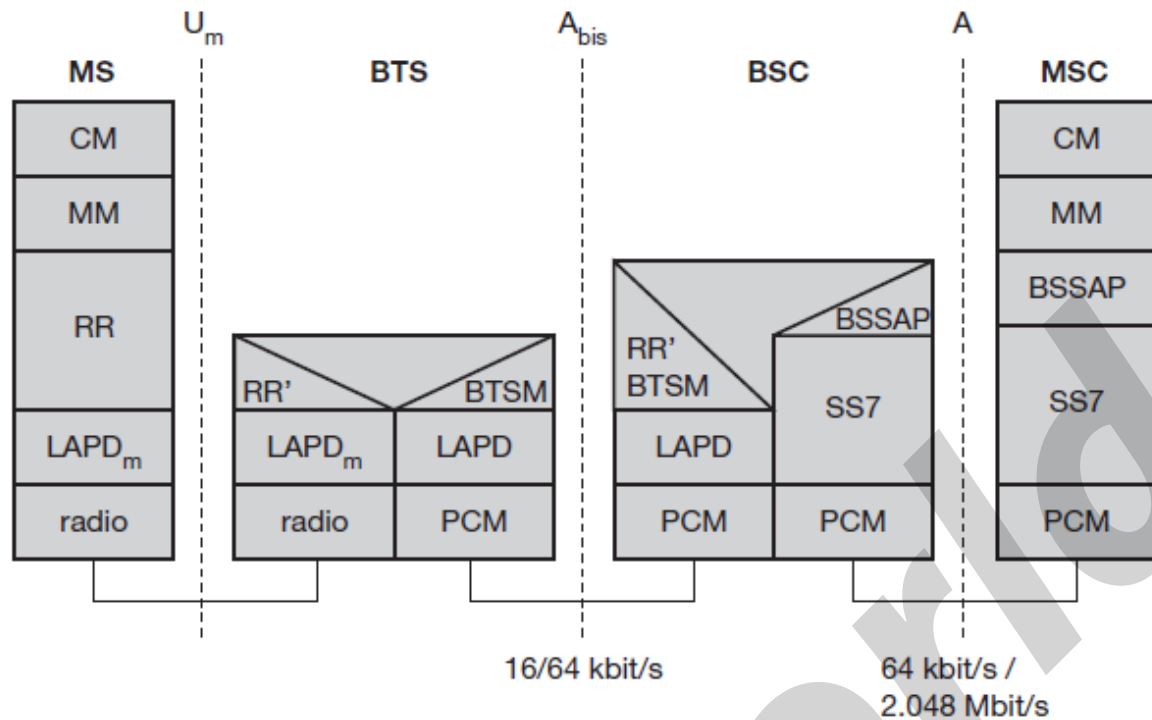

### Protocol architecture for Signaling

The main tasks of the physical layer comprise **channel coding** and **error detection/correction**, which is directly combined with the coding mechanisms. Channel coding makes extensive use of different **forward error correction (FEC)** schemes. Signaling between entities in a GSM network requires higher layers. For this purpose, the **LAPD<sub>m</sub>** protocol has been defined at the  $U_m$  interface for **layer two**. LAPD<sub>m</sub> has been derived from link access procedure for the D-channel (**LAPD**) in ISDN systems, which is a version of HDLC. LAPD<sub>m</sub> is a lightweight LAPD because it does not need synchronization flags or checksumming for error detection. LAPD<sub>m</sub> offers reliable data transfer over connections, re-sequencing of data frames, and flow control.

The network layer in GSM, layer three, comprises several sublayers. The lowest sublayer is the radio resource management (RR). Only a part of this layer, RR', is implemented in the BTS, the remainder is situated in the BSC. The functions of RR' are supported by the BSC via the BTS management (BTSM). The main tasks of RR are setup, maintenance, and release of radio channels. Mobility management (MM) contains functions for registration, authentication, identification, location updating, and the provision of a temporary mobile subscriber identity (TMSI).

Finally, the call management (CM) layer contains three entities: call control (CC), short message service (SMS), and supplementary service (SS). SMS allows for message transfer using the control channels SDCCH and SACCH, while SS offers the services like user identification, call redirection, or forwarding of ongoing calls. CC provides a point-to-point

connection between two terminals and is used by higher layers for call establishment, call clearing and change of call parameters. This layer also provides functions to send in-band tones, called dual tone multiple frequency (DTMF), over the GSM network. These tones are used, e.g., for the remote control of answering machines or the entry of PINs in electronic banking and are, also used for dialing in traditional analog telephone systems.

Additional protocols are used at the Abis and A interfaces. Data transmission at the physical layer typically uses **pulse code modulation (PCM)** systems. LAPD is used for layer two at Abis, BTSM for BTS management. **Signaling system No. 7 (SS7)** is used for signaling between an MSC and a BSC. This protocol also transfers all management information between MSCs, HLR, VLRs, AuC, EIR, and OMC. An MSC can also control a BSS via a **BSS application part (BSSAP)**.

### Localization and Calling

The fundamental feature of the GSM system is the automatic, worldwide localization of users for which, the system performs periodic location updates. The HLR always contains information about the current location and the VLR currently responsible for the MS informs the HLR about the location changes. Changing VLRs with uninterrupted availability is called roaming. Roaming can take place within a network of one provider, between two providers in a country and also between different providers in different countries.

To locate and address an MS, several numbers are needed:

- **Mobile station international ISDN number (MSISDN)**:- The only important number for a user of GSM is the phone number. This number consists of the country code (CC), the national destination code (NDC) and the subscriber number (SN).
- **International mobile subscriber identity (IMSI)**: GSM uses the IMSI for internal unique identification of a subscriber. IMSI consists of a mobile country code (MCC), the mobile network code (MNC), and finally the mobile subscriber identification number (MSIN).
- **Temporary mobile subscriber identity (TMSI)**: To hide the IMSI, which would give away the exact identity of the user signalling over the air interface, GSM uses the 4 byte TMSI for local subscriber identification.
- **Mobile station roaming number (MSRN)**: Another temporary address that hides the identity and location of a subscriber is MSRN. The VLR generates this address on request from the MSC, and the address is also stored in the HLR. MSRN contains the current visitor country code (VCC), the visitor national destination code (VNDC), the identification of the current MSC together with the subscriber number. The MSRN helps the HLR to find a subscriber for an incoming call.



For a mobile terminated call (MTC), the following figure shows the different steps that take place:

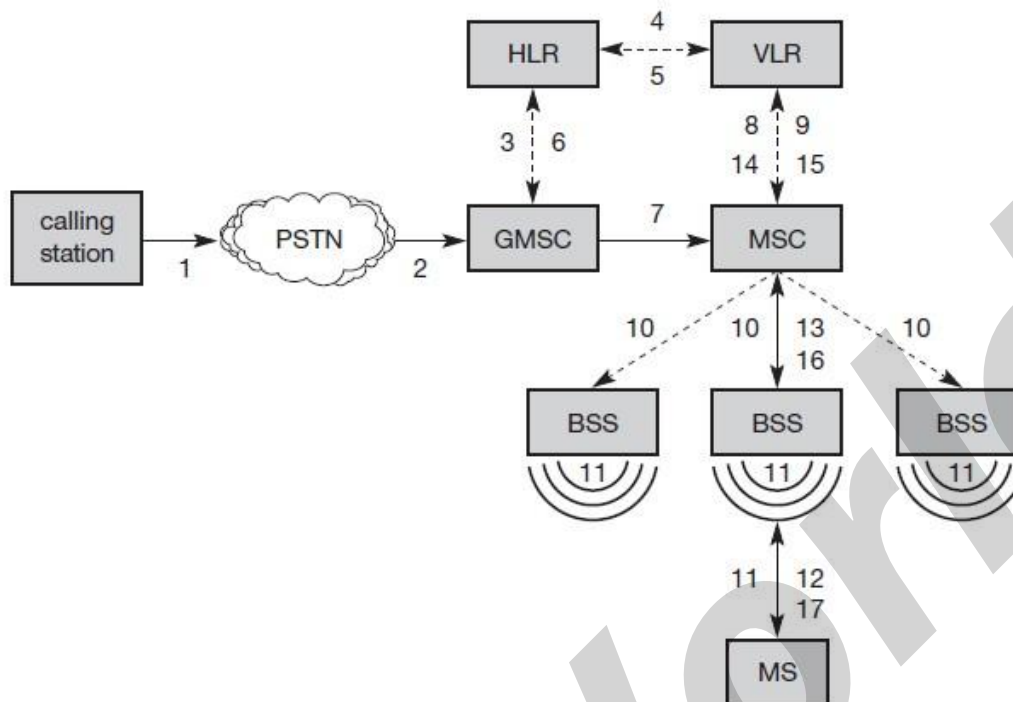

### Mobile Terminated Call (MTC)

- step 1:** User dials the phone number of a GSM subscriber.
- step 2:** The fixed network (PSTN) identifies the number belongs to a user in GSM network and forwards the call setup to the Gateway MSC (GMSC).
- step 3:** The GMSC identifies the HLR for the subscriber and signals the call setup to HLR
- step 4:** The HLR checks for number existence and its subscribed services and requests an MSRN from the current VLR.
- step 5:** VLR sends the MSRN to HLR
- step 6:** Upon receiving MSRN, the HLR determines the MSC responsible for MS and forwards the information to the GMSC
- step 7:** The GMSC can now forward the call setup request to the MSC indicated
- step 8:** The MSC requests the VLR for the current status of the MS
- step 9:** VLR sends the requested information
- step 10:** If MS is available, the MSC initiates paging in all cells it is responsible for.
- step 11:** The BTSs of all BSSs transmit the paging signal to the MS
- step 12:** **Step 13:** If MS answers, VLR performs security checks
- step 15:** **Till step 17:** Then the VLR signals to the MSC to setup a connection to the MS

For a **mobile originated call (MOC)**, the following steps take place:

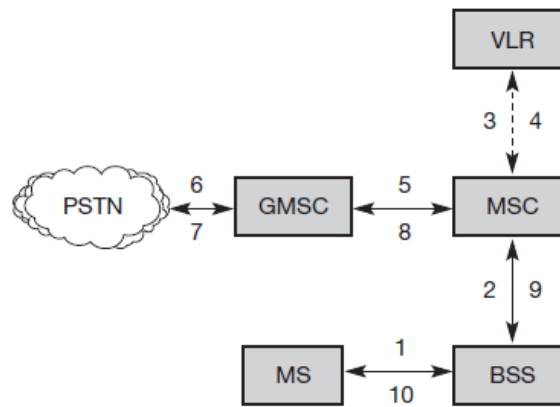

**step 1:** The MS transmits a request for a new connection

**step 2:** The BSS forwards this request to the MSC

**step 3: Step 4:** The MSC then checks if this user is allowed to set up a call with the requested and checks the availability of resources through the GSM network and into the PSTN. If all resources are available, the MSC sets up a connection between the MS and the fixed network.

In addition to the steps mentioned above, other messages are exchanged between an MS and BTS during connection setup (in either direction).

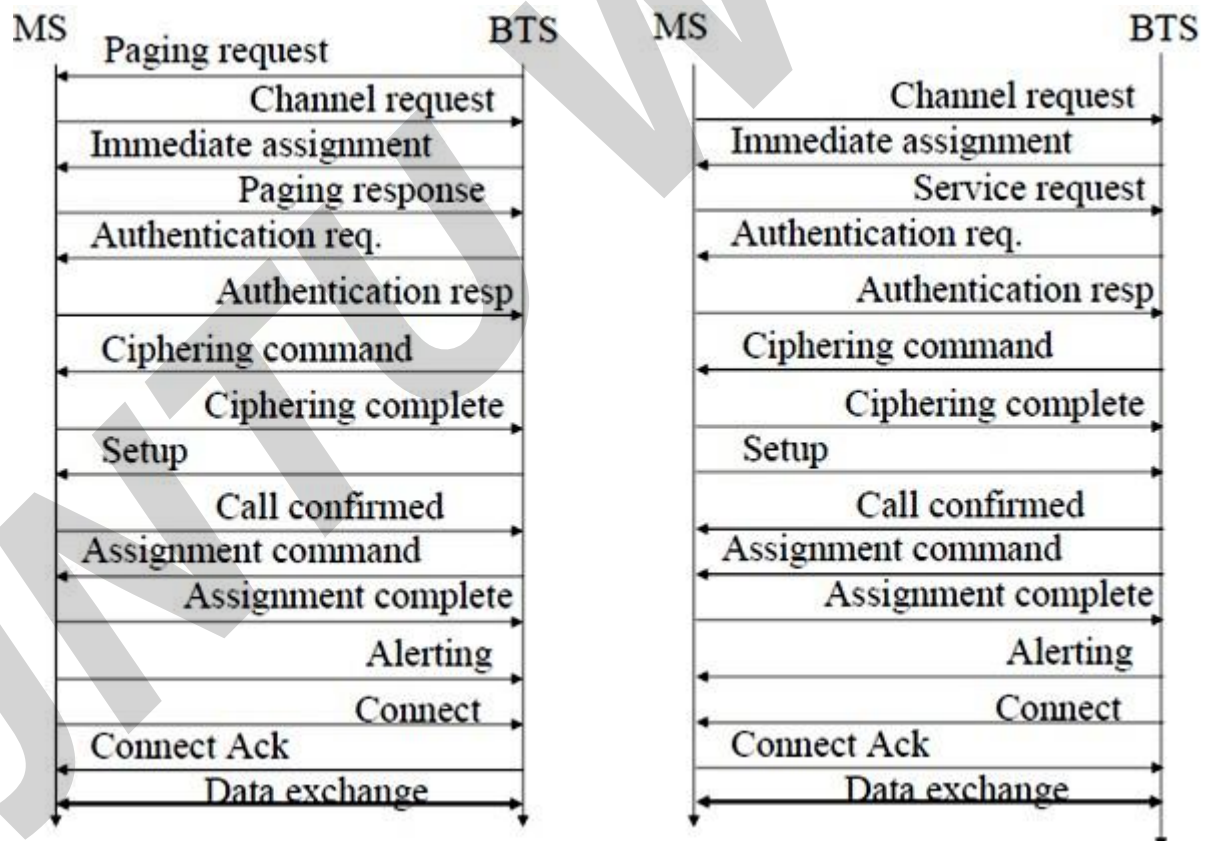

Message flow for MTC and MOC

## Handover

Cellular systems require **handover** procedures, as single cells do not cover the whole service area. However, a handover should not cause a cut-off, also called **call drop**. GSM aims at maximum handover duration of 60 ms. There are two basic reasons for a handover:

1. The mobile station **moves out of the range** of a BTS, decreasing the received **signal level** increasing the **error rate** thereby diminishing the **quality of the radio link**.
2. Handover may be due to **load balancing**, when an MSC/BSC decides the traffic is too high in one cell and shifts some MS to other cells with a lower load.

The four possible handover scenarios of GSM are shown below:

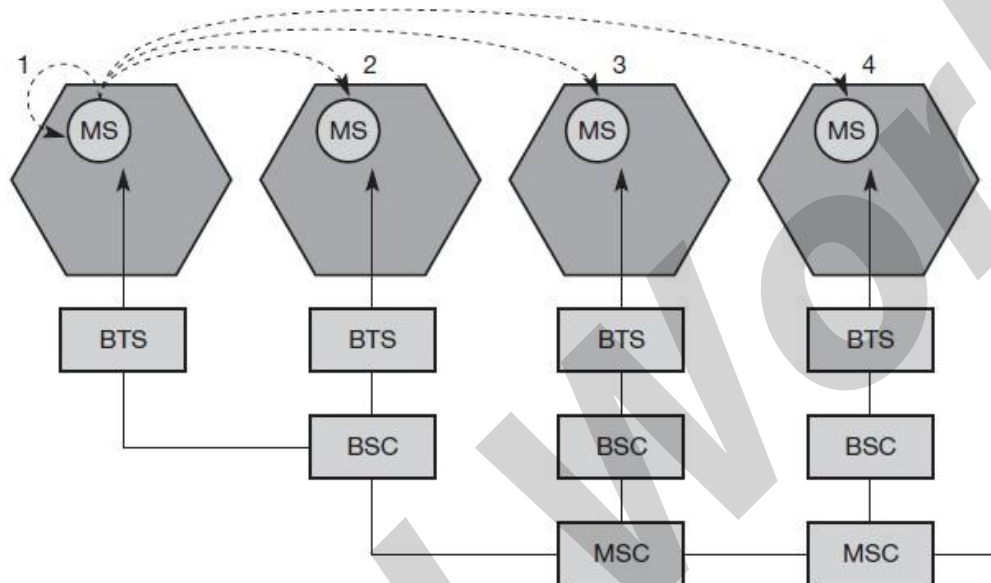

- **Intra-cell handover:** Within a cell, narrow-band interference could make transmission at a certain frequency impossible. The BSC could then decide to change the carrier frequency (scenario 1).
- **Inter-cell, intra-BSC handover:** This is a typical handover scenario. The mobile station moves from one cell to another, but stays within the control of the same BSC. The BSC then performs a handover, assigns a new radio channel in the new cell and releases the old one (scenario 2).
- **Inter-BSC, intra-MSC handover:** As a BSC only controls a limited number of cells; GSM also has to perform handovers between cells controlled by different BSCs. This handover then has to be controlled by the MSC (scenario 3).
- **Inter MSC handover:** A handover could be required between two cells belonging to different MSCs. Now both MSCs perform the handover together (scenario 4).

To provide all the necessary information for a handover due to a weak link, MS and BTS both perform periodic measurements of the downlink and uplink quality respectively. Measurement reports are sent by the MS about every half-second and contain the quality of the current link used for transmission as well as the quality of certain channels in neighboring cells (the BCCHs).

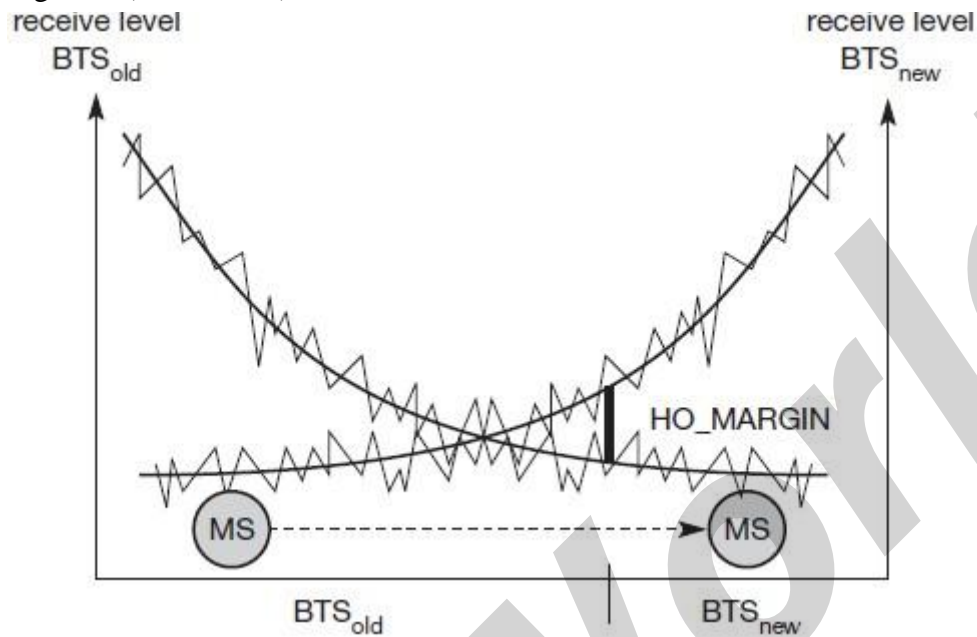

**Handover decision depending on receive level**

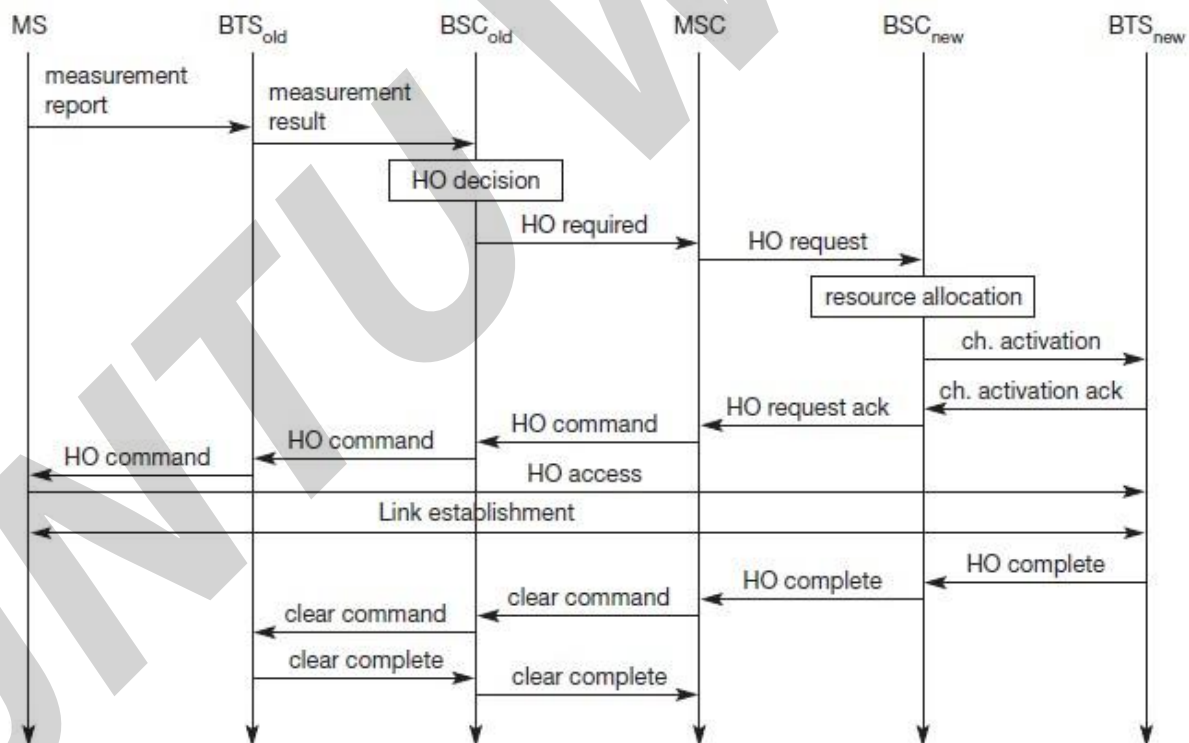

**Intra-MS handover**

More sophisticated handover mechanisms are needed for seamless handovers between different systems.

## Security

GSM offers several security services using confidential information stored in the AuC and in the individual SIM. The SIM stores personal, secret data and is protected with a PIN against unauthorized use. Three algorithms have been specified to provide security services in GSM. **Algorithm A3** is used for **authentication**, **A5** for **encryption**, and **A8** for the **generation of a cipher key**. The various security services offered by GSM are:

**Access control and authentication:** The first step includes the authentication of a valid user for the SIM. The user needs a secret PIN to access the SIM. The next step is the subscriber authentication. This step is based on a challenge-response scheme as shown below:

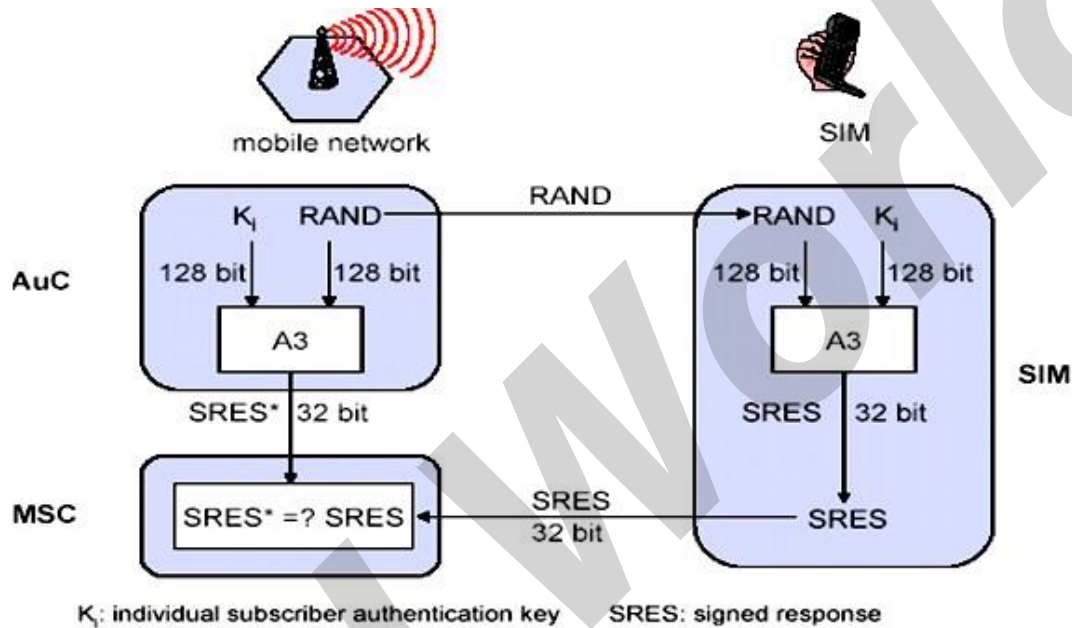

### Subscriber Authentication

Authentication is based on the SIM, which stores the **individual authentication key  $K_i$** , the **user identification IMSI**, and the algorithm used for authentication **A3**. The AuC performs the basic generation of random values RAND, signed responses SRES, and cipher keys  $K_c$  for each IMSI, and then forwards this information to the HLR. The current VLR requests the appropriate values for RAND, SRES, and  $K_c$  from the HLR. For authentication, the VLR sends the random value RAND to the SIM. Both sides, network and subscriber module, perform the same operation with RAND and the key  $K_i$ , called **A3**. The MS sends back the SRES generated by the SIM; the VLR can now compare both values. If they are the same, the VLR accepts the subscriber, otherwise the subscriber is rejected.

**Confidentiality:** All user-related data is encrypted. After authentication, BTS and MS apply encryption to voice, data, and signalling as shown below.

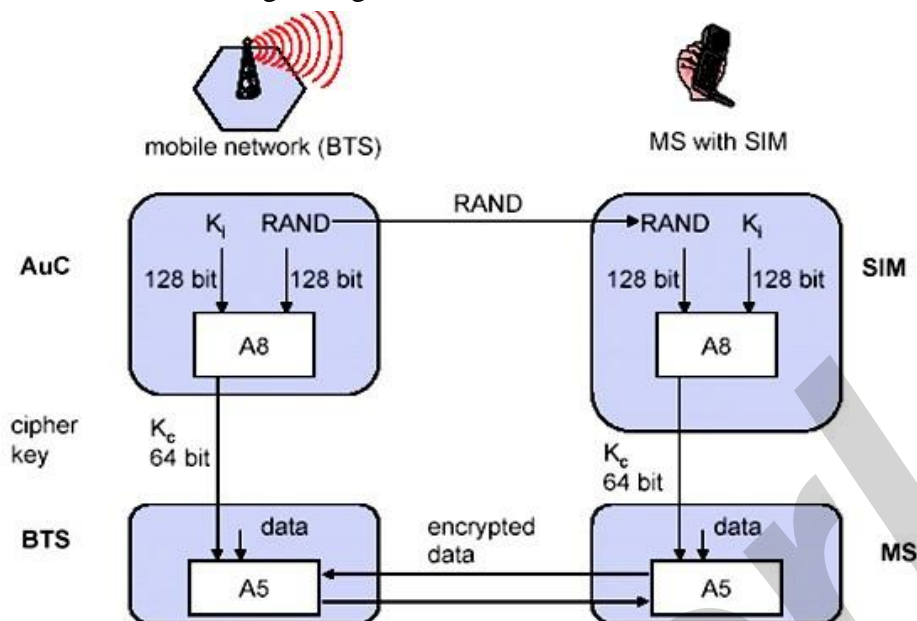

To ensure privacy, all messages containing user-related information are encrypted in GSM over the air interface. After authentication, MS and BSS can start using encryption by applying the cipher key  $K_c$ , which is generated using the individual key  $K_i$  and a random value by applying the algorithm A8. Note that the SIM in the MS and the network both calculate the same  $K_c$  based on the random value  $RAND$ . The key  $K_c$  itself is not transmitted over the air interface. MS and BTS can now encrypt and decrypt data using the algorithm A5 and the cipher key  $K_c$ .

**Anonymity:** To provide user anonymity, all data is encrypted before transmission, and user identifiers are not used over the air. Instead, GSM transmits a temporary identifier (TMSI), which is newly assigned by the VLR after each location update. Additionally, the VLR can change the TMSI at any time.

### New Data Services

To enhance the data transmission capabilities of GSM, two basic approaches are possible. As the basic GSM is based on connection-oriented traffic channels, e.g., with 9.6 kbit/s each, several channels could be combined to increase bandwidth. This system is called **HSCSD**

{**high speed circuit switched data**}. A more progressive step is the introduction of packet-oriented traffic in GSM, i.e., shifting the paradigm from connections/telephone thinking to packets/internet thinking. The system is called **GPRS** {**general packet radio service**}.

**HSCD:** A straightforward improvement of GSM's data transmission capabilities is high speed circuit switched data (HSCSD) in which higher data rates are achieved by bundling several TCHs. An MS requests one or more TCHs from the GSM network, i.e., it allocates several TDMA slots within a TDMA frame. This allocation can be asymmetrical, i.e. more slots can be allocated on the downlink than on the uplink, which fits the typical user behaviour of downloading more data compared to uploading. A major disadvantage of HSCD is that it still uses the connection-oriented mechanisms of GSM, which is not efficient for computer data traffic.

**GPRS:** The next step toward more flexible and powerful data transmission avoids the problems of HSCSD by being fully packet-oriented. The **general packet radio service (GPRS)** provides packet mode transfer for applications that exhibit traffic patterns such as frequent transmission of small volumes (e.g., typical web requests) or infrequent transmissions of small or medium volumes (e.g., typical web responses) according to the requirement specification. For the new GPRS radio channels, the GSM system can allocate between one and eight time slots within a TDMA frame. Time slots are not allocated in a fixed, pre-determined manner but on demand. All time slots can be shared by the active users; up- and downlink are allocated separately. Allocation of the slots is based on current load and operator preferences. The GPRS concept is independent of channel characteristics and of the type of channel (traditional GSM traffic or control channel), and does not limit the maximum data rate (only the GSM transport system limits the rate). All GPRS services can be used in parallel to conventional services. GPRS includes several **security services** such as authentication, access control, user identity confidentiality, and user information confidentiality.

The GPRS architecture introduces two new network elements, which are called GPRS support nodes (GSN) and are in fact routers. All GSNs are integrated into the standard GSM architecture, and many new interfaces have been defined. The gateway GPRS support node (GGSN) is the interworking unit between the GPRS network and external packet data networks (PDN). This node contains routing information for GPRS users, performs address conversion, and tunnels data to a user via encapsulation. The GGSN is connected to external networks (e.g., IP or X.25) via the Gi interface and transfers packets to the SGSN via an IP- based GPRS backbone network (Gn interface). The other new element is the **serving GPRS support node (SGSN)** which supports the MS via the Gb interface. The SGSN, for example, requests user addresses from the **GPRS register (GR)**, keeps track of the individual MSs' location, is responsible for collecting billing information (e.g., counting bytes), and performs several security functions such as access control. The SGSN is connected to a BSC via frame

relay and is basically on the same hierarchy level as an MSC. The GR, which is typically a part of the HLR, stores all GPRS-relevant data.

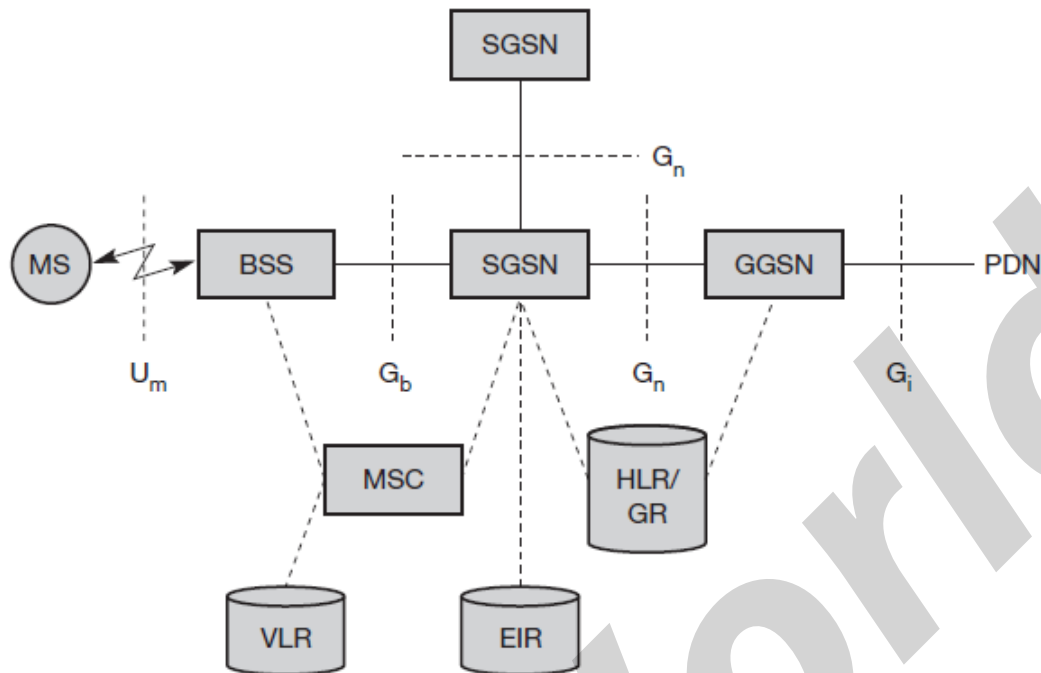

#### GPRS Architecture Reference Model

As shown above, packet data is transmitted from a PDN, via the GGSN and SGSN directly to the BSS and finally to the MS. The MSC, which is responsible for data transport in the traditional circuit-switched GSM, is only used for signalling in the GPRS scenario. Before sending any data over the GPRS network, an MS must attach to it, following the procedures of the **mobility management**. The attachment procedure includes assigning a temporal identifier, called a **temporary logical link identity (TLLI)**, and a **ciphering key sequence number (CKSN)** for data encryption. For each MS, a **GPRS context** is set up and stored in the MS and in the corresponding SGSN. Besides attaching and detaching, mobility management also comprises functions for authentication, location management, and ciphering.

The following figure shows the protocol architecture of the transmission plane for GPRS. All data within the GPRS backbone, i.e., between the GSNs, is transferred using the **GPRS tunnelling protocol (GTP)**. GTP can use two different transport protocols, either the reliable **TCP** (needed for reliable transfer of X.25 packets) or the non-reliable **UDP** (used for IP packets). The network protocol for the GPRS backbone is **IP** (using any lower layers). To adapt to the different characteristics of the underlying networks, the **subnetwork dependent convergence protocol (SNDCP)** is used between an SGSN and the MS. On top of SNDCP and GTP, user packet data is tunneled from the MS to the GGSN and vice versa. To achieve a high reliability of packet transfer between SGSN and MS, a special LLC is used, which comprises ARQ and FEC mechanisms for PTP (and later PTM) services.



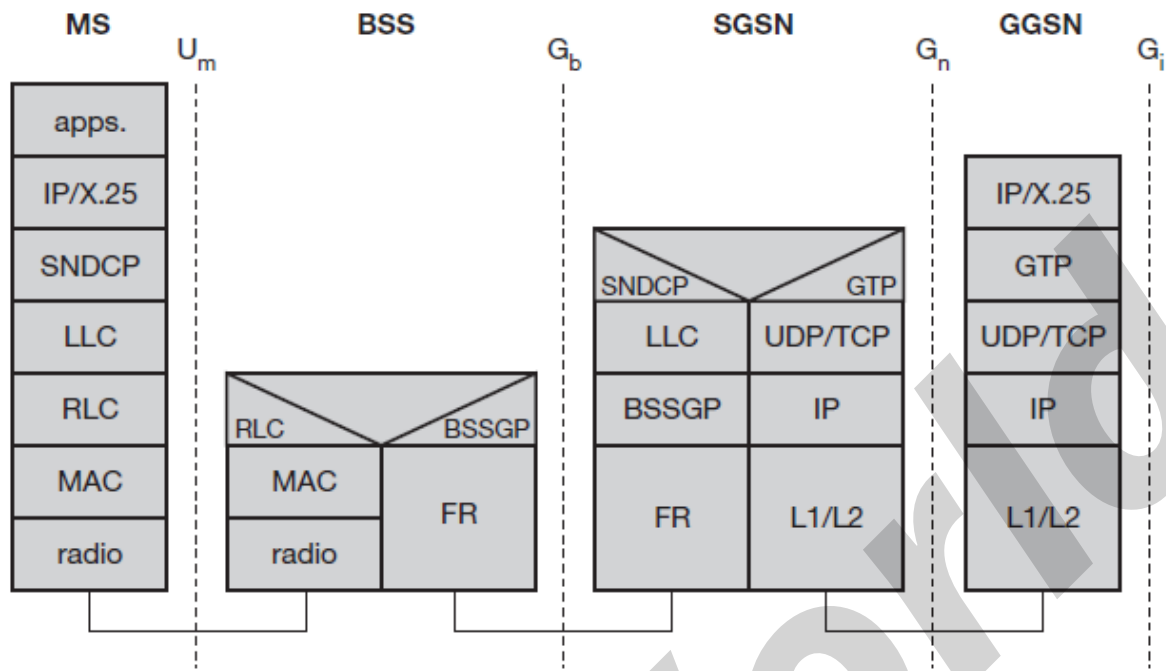

**GPRS transmission plane protocol reference model**

A base station subsystem GPRS protocol (BSSGP) is used to convey routing and QoS- related information between the BSS and SGSN. BSSGP does not perform error correction and works on top of a frame relay (FR) network. Finally, radio link dependent protocols are needed to transfer data over the Um interface. The radio link protocol (RLC) provides a reliable link, while the MAC controls access with signalling procedures for the radio channel and the mapping of LLC frames onto the GSM physical channels. The radio interface at Um needed for GPRS does not require fundamental changes compared to standard GSM.

## Unit:2

The **Media Access Control (MAC)** data communication protocol sub-layer, also known as the Medium Access Control, is a sublayer of the Data Link Layer specified in the seven-layer OSI model (layer 2). The hardware that implements the MAC is referred to as a **Medium Access Controller**. The MAC sub-layer acts as an interface between the Logical Link Control (LLC) sublayer and the network's physical layer. The MAC layer emulates a full-duplex logical communication channel in a multi-point network. This channel may provide unicast, multicast or broadcast communication service.

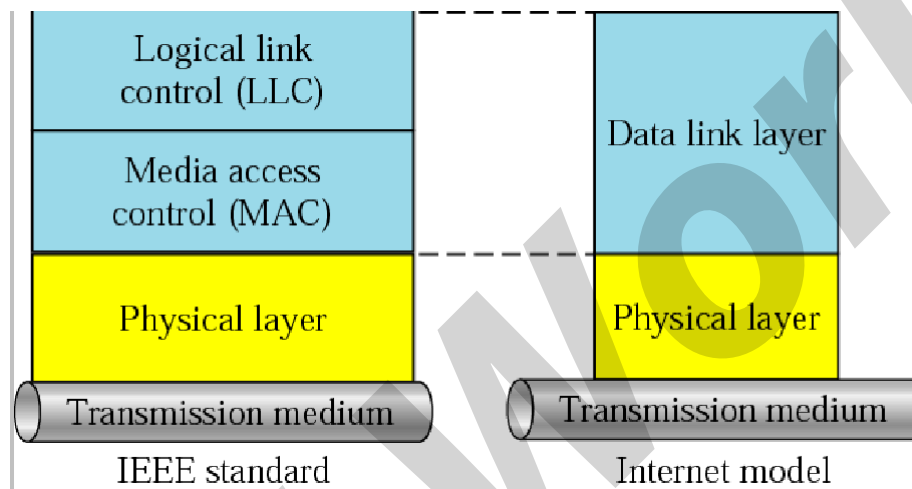

*LLC and MAC sublayers*

### Motivation for a specialized MAC

One of the most commonly used MAC schemes for wired networks is carrier sense multiple access with collision detection (CSMA/CD). In this scheme, a sender senses the medium (a wire or coaxial cable) to see if it is free. If the medium is busy, the sender waits until it is free. If the medium is free, the sender starts transmitting data and continues to listen into the medium. If the sender detects a collision while sending, it stops at once and sends a jamming signal. But this scheme does not work well with wireless networks. The problems are:

- Signal strength decreases proportional to the square of the distance
- The sender would apply CS and CD, but the collisions happen at the receiver
- It might be a case that a sender cannot “hear” the collision, i.e., CD does not work
- Furthermore, CS might not work, if for e.g., a terminal is “hidden”

### Hidden and Exposed Terminals

Consider the scenario with three mobile phones as shown below. The transmission range of A reaches B, but not C (the detection range does not reach C either). The transmission range of C reaches B, but not A. Finally, the transmission range of B reaches A and C, i.e., A cannot detect C and vice versa.

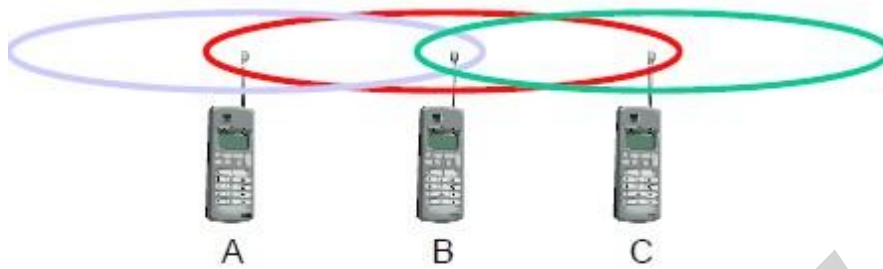

### Hidden terminals

- A sends to B, C cannot hear A
- C wants to send to B, C senses a “free” medium (CS fails) and starts transmitting
- Collision at B occurs, A cannot detect this collision (CD fails) and continues with its transmission to B
- A is “hidden” from C and vice versa

### Exposed terminals

- B sends to A, C wants to send to another terminal (not A or B) outside the range
- C senses the carrier and detects that the carrier is busy.
- C postpones its transmission until it detects the medium as being idle again
- but A is outside radio range of C, waiting is **not** necessary
- C is “exposed” to B

Hidden terminals cause collisions, whereas Exposed terminals cause unnecessary delay.

### Near and far terminals

Consider the situation shown below. A and B are both sending with the same transmission power.

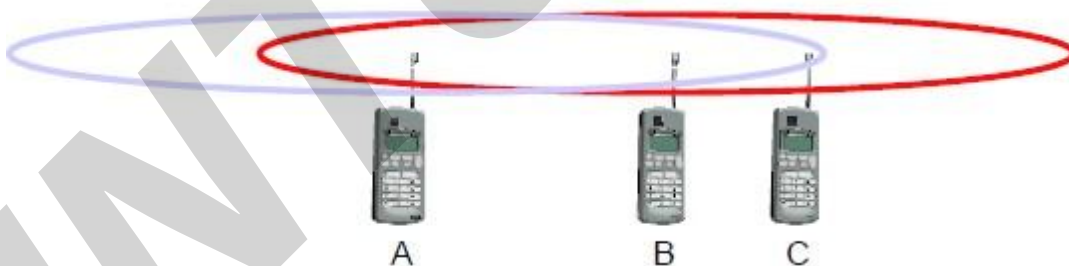

- Signal strength decreases proportional to the square of the distance
- So, B’s signal drowns out A’s signal making C unable to receive A’s transmission
- If C is an arbiter for sending rights, B drowns out A’s signal on the physical layer making C unable to hear out A.

The **near/far effect** is a severe problem of wireless networks using CDM. All signals should arrive at the receiver with more or less the same strength for which Precise power control is to be implemented.

### SDMA

**Space Division Multiple Access (SDMA)** is used for allocating a separated space to users in wireless networks. A typical application involves assigning an optimal base station to a mobile phone user. The mobile phone may receive several base stations with different quality. A MAC algorithm could now decide which base station is best, taking into account which frequencies (FDM), time slots (TDM) or code (CDM) are still available. The basis for the SDMA algorithm is formed by cells and sectorized antennas which constitute the infrastructure implementing **space division multiplexing (SDM)**. SDM has the unique advantage of not requiring any multiplexing equipment. It is usually combined with other multiplexing techniques to better utilize the individual physical channels.

### FDMA

Frequency division multiplexing (FDM) describes schemes to subdivide the frequency dimension into several non-overlapping frequency bands.

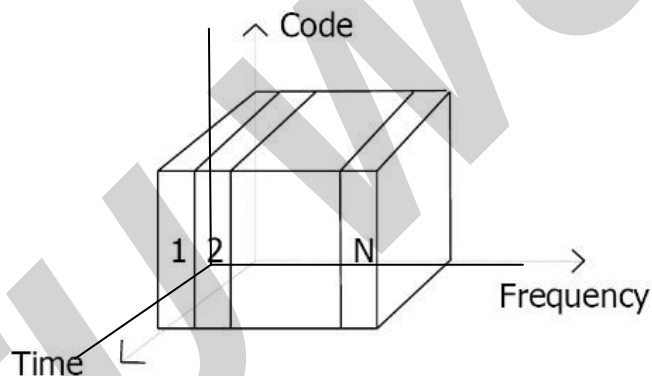

Frequency Division Multiple Access is a method employed to permit several users to transmit simultaneously on one satellite transponder by assigning a specific frequency within the channel to each user. Each conversation gets its own, unique, radio channel. The channels are relatively narrow, usually 30 KHz or less and are defined as either transmit or receive channels. A full duplex conversation requires a transmit & receive channel pair. FDM is often used for simultaneous access to the medium by base station and mobile station in cellular networks establishing a duplex channel. A scheme called **frequency division duplexing (FDD)** in which the two directions, mobile station to base station and vice versa are now separated using different frequencies.

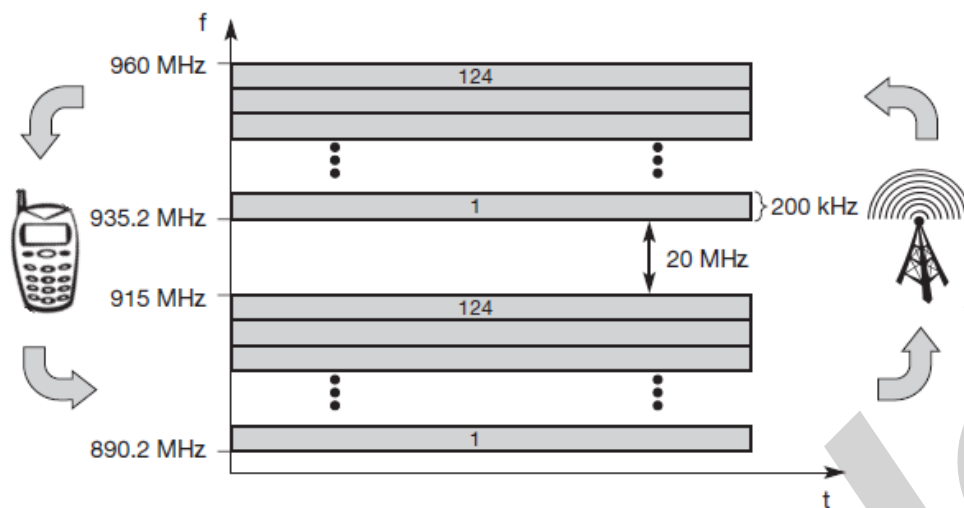

### FDMA for multiple access and duplex

The two frequencies are also known as **uplink**, i.e., from mobile station to base station or from ground control to satellite, and as **downlink**, i.e., from base station to mobile station or from satellite to ground control. The basic frequency allocation scheme for GSM is fixed and regulated by national authorities. All uplinks use the band between 890.2 and 915 MHz, all downlinks use 935.2 to 960 MHz. According to FDMA, the base station, shown on the right side, allocates a certain frequency for up- and downlink to establish a duplex channel with a mobile phone. Up- and downlink have a fixed relation. If the uplink frequency is  $f_u = 890 \text{ MHz} + n \cdot 0.2 \text{ MHz}$ , the downlink frequency is  $f_d = f_u + 45 \text{ MHz}$ ,

- **.,  $f_d = 935 \text{ MHz} + n \cdot 0.2 \text{ MHz}$**  for a certain channel  $n$ . The base station selects the channel. Each channel (uplink and downlink) has a bandwidth of 200 kHz.

This scheme also has disadvantages. While radio stations broadcast 24 hours a day, mobile communication typically takes place for only a few minutes at a time. Assigning a separate frequency for each possible communication scenario would be a tremendous waste of (scarce) frequency resources. Additionally, the fixed assignment of a frequency to a sender makes the scheme very inflexible and limits the number of senders.

### **TDMA**

A more flexible multiplexing scheme for typical mobile communications is time division multiplexing (TDM). Compared to FDMA, time division multiple access (TDMA) offers a much more flexible scheme, which comprises all technologies that allocate certain time slots for communication. Now synchronization between sender and receiver has to be achieved in the time domain. Again this can be done by using a fixed pattern similar to FDMA techniques, i.e., allocating a certain time slot for a channel, or by using a dynamic allocation scheme.

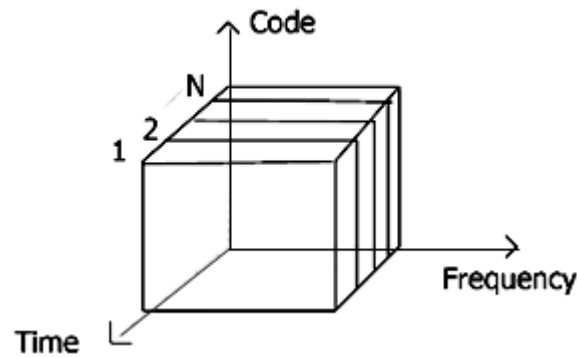

Listening to different frequencies at the same time is quite difficult, but listening to many channels separated in time at the same frequency is simple. Fixed schemes do not need identification, but are not as flexible considering varying bandwidth requirements.

### Fixed TDM

The simplest algorithm for using TDM is allocating time slots for channels in a fixed pattern. This results in a fixed bandwidth and is the typical solution for wireless phone systems. MAC is quite simple, as the only crucial factor is accessing the reserved time slot at the right moment. If this synchronization is assured, each mobile station knows its turn and no interference will happen. The fixed pattern can be assigned by the base station, where competition between different mobile stations that want to access the medium is solved.

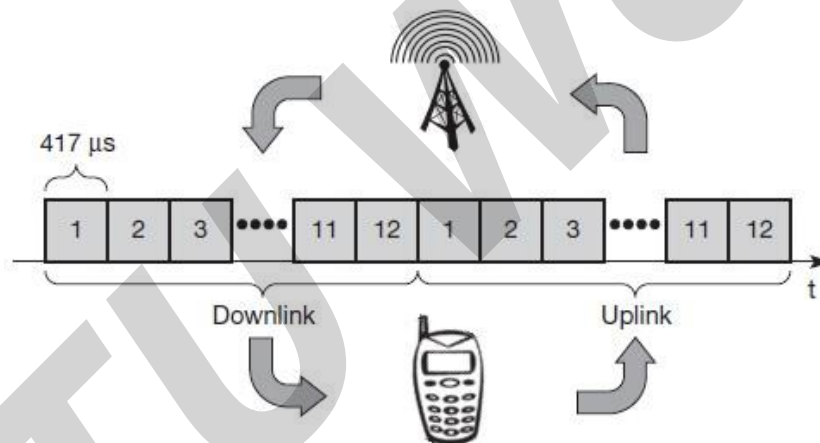

The above figure shows how these fixed TDM patterns are used to implement multiple access and a duplex channel between a base station and mobile station. Assigning different slots for uplink and downlink using the same frequency is called **time division duplex (TDD)**. As shown in the figure, the base station uses one out of 12 slots for the downlink, whereas the mobile station uses one out of 12 different slots for the uplink. Uplink and downlink are separated in time. Up to 12 different mobile stations can use the same frequency without interference using this scheme. Each connection is allotted its own up- and downlink pair. This general scheme still wastes a lot of bandwidth. It is too static, too inflexible for data communication. In this case, connectionless, demand-oriented TDMA schemes can be used

### Classical Aloha

In this scheme, TDM is applied without controlling medium access. Here each station can access the medium at any time as shown below:

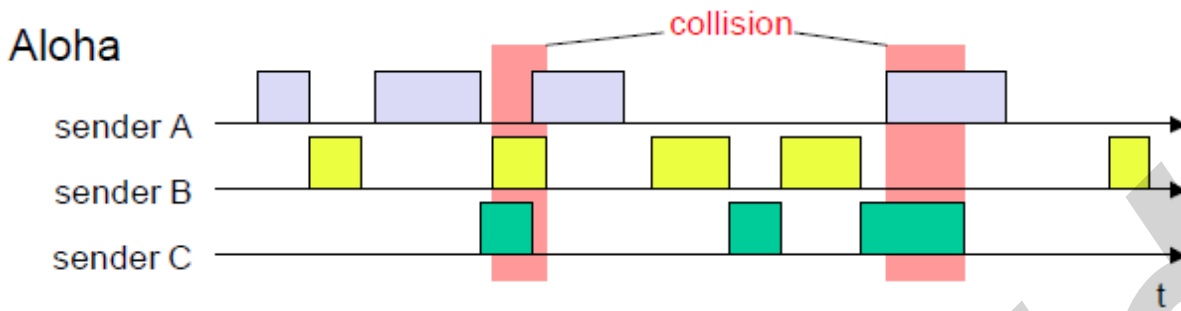

This is a random access scheme, without a central arbiter controlling access and without coordination among the stations. If two or more stations access the medium at the same time, a **collision** occurs and the transmitted data is destroyed. Resolving this problem is left to higher layers (e.g., retransmission of data). The simple Aloha works fine for a light load and does not require any complicated access mechanisms.

### Slotted Aloha

The first refinement of the classical Aloha scheme is provided by the introduction of time slots (**slotted Aloha**). In this case, all senders have to be **synchronized**, transmission can only start at the beginning of a **time slot** as shown below.

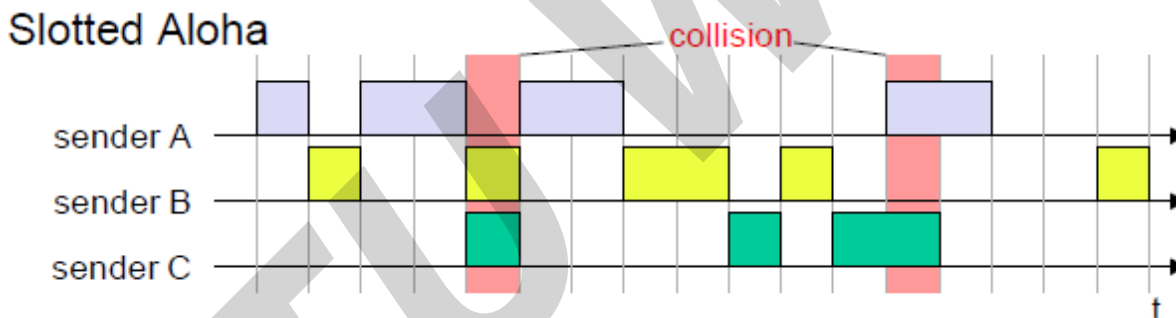

The introduction of slots raises the throughput from 18 per cent to 36 per cent, i.e., slotting doubles the throughput. Both basic Aloha principles occur in many systems that implement distributed access to a medium. Aloha systems work perfectly well under a light load, but they cannot give any hard transmission guarantees, such as maximum delay before accessing the medium or minimum throughput.

### Carrier sense multiple access

One improvement to the basic Aloha is sensing the carrier before accessing the medium. Sensing the carrier and accessing the medium only if the carrier is idle decreases the probability of a

collision. But, as already mentioned in the introduction, hidden terminals cannot be detected, so, if a hidden terminal transmits at the same time as another sender, a collision might occur at the receiver. This basic scheme is still used in most wireless LANs. The different versions of CSMA are:

- **1-persistent CSMA:** Stations sense the channel and listens if its busy and transmit immediately, when the channel becomes idle. It's called 1-persistent CSMA because the host transmits with a probability of 1 whenever it finds the channel idle.
- **non-persistent CSMA:** stations sense the carrier and start sending immediately if the medium is idle. If the medium is busy, the station pauses a random amount of time before sensing the medium again and repeating this pattern.
- **p-persistent CSMA:** systems nodes also sense the medium, but only transmit with a probability of  $p$ , with the station deferring to the next slot with the probability  $1-p$ , i.e., access is slotted in addition

CSMA with collision avoidance (CSMA/CA) is one of the access schemes used in wireless LANs following the standard IEEE 802.11. Here sensing the carrier is combined with a back-off scheme in case of a busy medium to achieve some fairness among competing stations.

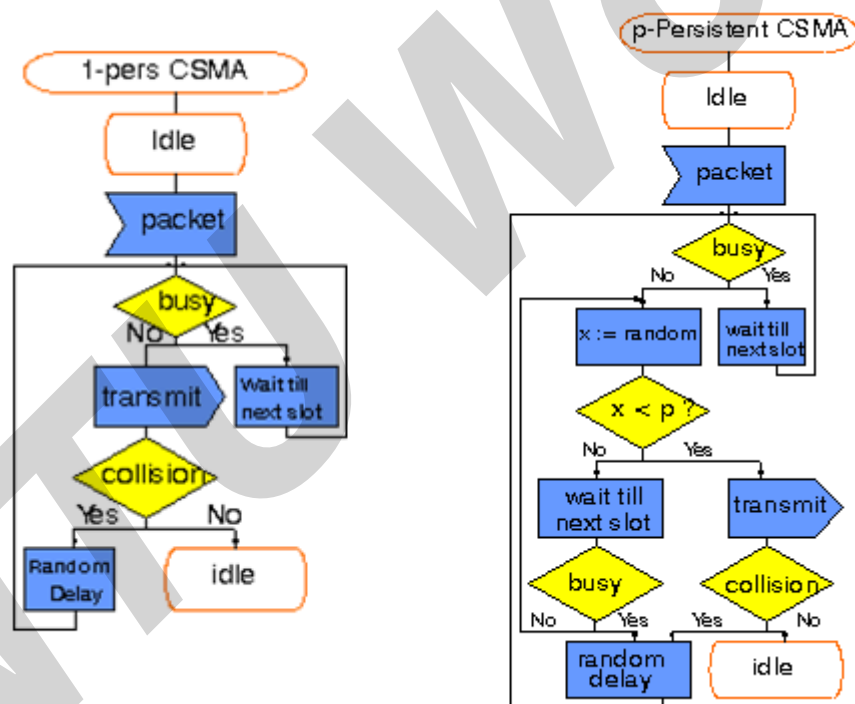

### Demand assigned multiple access

Channel efficiency for Aloha is 18% and for slotted Aloha is 36%. It can be increased to 80% by implementing reservation mechanisms and combinations with some (fixed) TDM patterns. These schemes typically have a reservation period followed by a transmission period. During the



reservation period, stations can reserve future slots in the transmission period. While, depending on the scheme, collisions may occur during the reservation period, the transmission period can then be accessed without collision.

One basic scheme is **demand assigned multiple access (DAMA)** also called **reservation Aloha**, a scheme typical for satellite systems. It increases the amount of users in a pool of satellite channels that are available for use by any station in a network. It is assumed that not all users will need simultaneous access to the same communication channels. So that a call can be established, DAMA assigns a pair of available channels based on requests issued from a user. Once the call is completed, the channels are returned to the pool for an assignment to another call. Since the resources of the satellite are being used only in proportion to the occupied channels for the time in which they are being held, it is a perfect environment for voice traffic and data traffic in batch mode.

It has two modes as shown below.



During a contention phase following the slotted Aloha scheme; all stations can try to reserve future slots. Collisions during the reservation phase do not destroy data transmission, but only the short requests for data transmission. If successful, a time slot in the future is reserved, and no other station is allowed to transmit during this slot. Therefore, the satellite collects all successful requests (the others are destroyed) and sends back a reservation list indicating access rights for future slots. All ground stations have to obey this list. To maintain the fixed TDM pattern of reservation and transmission, the stations have to be synchronized from time to time. DAMA is an **explicit reservation** scheme. Each transmission slot has to be reserved explicitly.

### **PRMA packet reservation multiple access**

It is a kind of implicit reservation scheme where, slots can be reserved implicitly. A certain number of slots form a frame. The frame is repeated in time i.e., a fixed TDM pattern is applied. A base station, which could be a satellite, now broadcasts the status of each slot to all mobile stations. All stations receiving this vector will then know which slot is occupied and which slot is currently free.

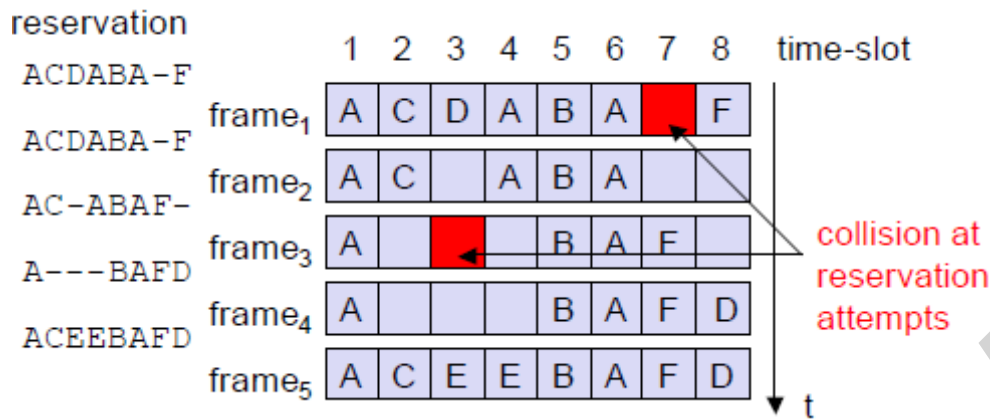

The base station broadcasts the reservation status 'ACDABA-F' to all stations, here A to F. This means that slots one to six and eight are occupied, but slot seven is free in the following transmission. All stations wishing to transmit can now compete for this free slot in Aloha fashion. The already occupied slots are not touched. In the example shown, more than one station wants to access this slot, so a collision occurs. The base station returns the reservation status 'ACDABA-F', indicating that the reservation of slot seven failed (still indicated as free) and that nothing has changed for the other slots. Again, stations can compete for this slot. Additionally, station D has stopped sending in slot three and station F in slot eight. This is noticed by the base station after the second frame. Before the third frame starts, the base station indicates that slots three and eight are now idle. Station F has succeeded in reserving slot seven as also indicated by the base station.

As soon as a station has succeeded with a reservation, all future slots are implicitly reserved for this station. This ensures transmission with a guaranteed data rate. The slotted aloha scheme is used for idle slots only; data transmission is not destroyed by collision.

### Reservation TDMA

In a fixed TDM scheme  $N$  mini-slots followed by  $N \cdot k$  data-slots form a frame that is repeated. Each station is allotted its own mini-slot and can use it to reserve up to  $k$  data-slots.

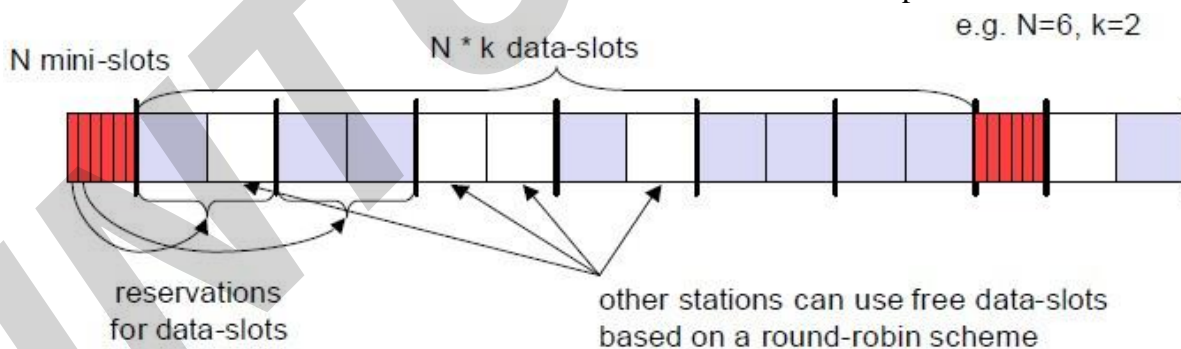

This guarantees each station a certain bandwidth and a fixed delay. Other stations can now send data in unused data-slots as shown. Using these free slots can be based on a simple round-robin scheme or can be uncoordinated using an Aloha scheme. This scheme allows for the combination of, e.g., isochronous traffic with fixed bitrates and best-effort traffic without any guarantees.

### Multiple access with collision avoidance

Multiple access with collision avoidance (MACA) presents a simple scheme that solves the hidden terminal problem, does not need a base station, and is still a random access Aloha scheme – but with dynamic reservation. Consider the hidden terminal problem scenario.

A starts sending to B, C does not receive this transmission. C also wants to send something to B and senses the medium. The medium appears to be free, the carrier sense fails. C also starts sending causing a collision at B. But A cannot detect this collision at B and continues with its transmission. A is **hidden** for C and vice versa.

With MACA, A does not start its transmission at once, but sends a **request to send (RTS)** first. B receives the RTS that contains the name of sender and receiver, as well as the length of the future transmission. This RTS is not heard by C, but triggers an acknowledgement from B, called **clear to send (CTS)**. The CTS again contains the names of sender (A) and receiver (B) of the user data, and the length of the future transmission.

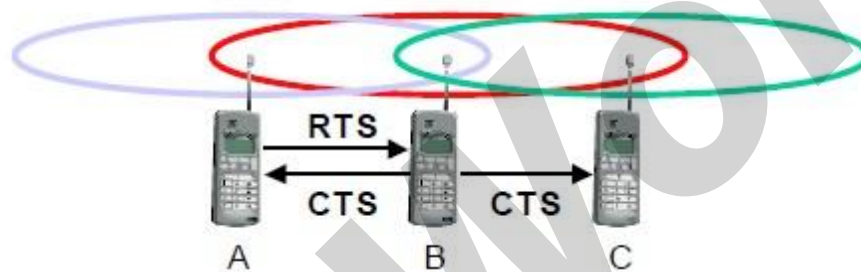

This CTS is now heard by C and the medium for future use by A is now reserved for the duration of the transmission. After receiving a CTS, C is not allowed to send anything for the duration indicated in the CTS toward B. A collision cannot occur at B during data transmission, and the hidden terminal problem is solved. Still collisions might occur when A and C transmits a RTS at the same time. B resolves this contention and acknowledges only one station in the CTS. No transmission is allowed without an appropriate CTS.

Now MACA tries to avoid the **exposed terminals** in the following way:

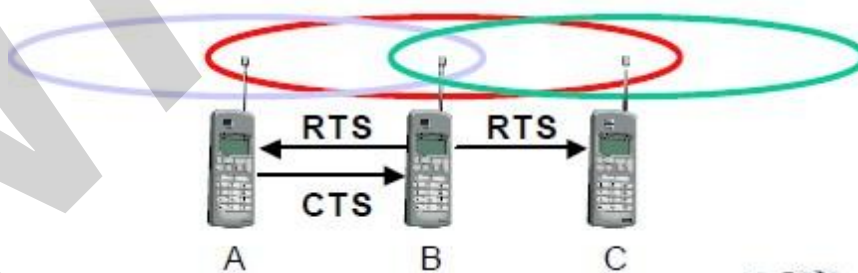

With MACA, B has to transmit an RTS first containing the name of the receiver (A) and the sender (B). C does not react to this message as it is not the receiver, but A acknowledges using a CTS which identifies B as the sender and A as the receiver of the following data transmission. C does not receive this CTS and concludes that A is outside the detection range. C can start its transmission

assuming it will not cause a collision at A. The problem with exposed terminals is solved without fixed access patterns or a base station.

### Polling

Polling schemes are used when one station wants to be heard by others. Polling is a strictly centralized scheme with one master station and several slave stations. The master can poll the slaves according to many schemes: round robin (only efficient if traffic patterns are similar over all stations), randomly, according to reservations (the classroom example with polite students) etc. The master could also establish a list of stations wishing to transmit during a contention phase. After this phase, the station polls each station on the list.

Example: Randomly Addressed Polling

- base station signals readiness to all mobile terminals
- terminals ready to send transmit random number without collision using CDMA or FDMA
- the base station chooses one address for polling from list of all random numbers (collision if two terminals choose the same address)
- the base station acknowledges correct packets and continues polling the next terminal
- this cycle starts again after polling all terminals of the list

### Inhibit sense multiple access

This scheme, which is used for the packet data transmission service Cellular Digital Packet Data (CDPD) in the AMPS mobile phone system, is also known as **digital sense multiple access (DSMA)**. Here, the base station only signals a busy medium via a busy tone (called BUSY/IDLE indicator) on the downlink.

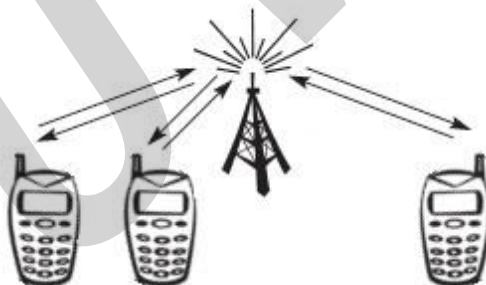

After the busy tone stops, accessing the uplink is not coordinated any further. The base station acknowledges successful transmissions; a mobile station detects a collision only via the missing positive acknowledgement. In case of collisions, additional back-off and retransmission mechanisms are implemented.

## CDMA

Code division multiple access systems apply codes with certain characteristics to the transmission to separate different users in code space and to enable access to a shared medium without interference.

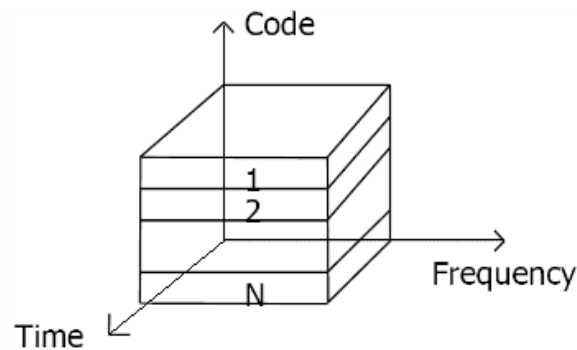

All terminals send on the same frequency probably at the same time and can use the whole bandwidth of the transmission channel. Each sender has a unique random number, the sender XORs the signal with this random number. The receiver can “tune” into this signal if it knows the pseudo random number, tuning is done via a correlation function

### Disadvantages:

- higher complexity of a receiver (receiver cannot just listen into the medium and start receiving if there is a signal)
- all signals should have the same strength at a receiver

### Advantages:

- all terminals can use the same frequency, no planning needed
- huge code space (e.g.  $2^{32}$ ) compared to frequency space
- interferences (e.g. white noise) is not coded
- forward error correction and encryption can be easily integrated

- Sender A
  - sends  $A_d = 1$ , key  $A_k = 010011$  (assign: “0”= -1, “1”= +1)
  - sending signal  $A_s = A_d * A_k = (-1, +1, -1, -1, +1, +1)$
- Sender B
  - sends  $B_d = 0$ , key  $B_k = 110101$  (assign: “0”= -1, “1”= +1)
  - sending signal  $B_s = B_d * B_k = (-1, -1, +1, -1, +1, -1)$
- Both signals superimpose in space
  - interference neglected (noise etc.)
  - $A_s + B_s = (-2, 0, 0, -2, +2, 0)$
- Receiver wants to receive signal from sender A
  - apply key  $A_k$  bitwise (inner product)
    - $A_e = (-2, 0, 0, -2, +2, 0) \bullet A_k = 2 + 0 + 0 + 2 + 2 + 0 = 6$
    - result greater than 0, therefore, original bit was “1”
  - receiving B
    - $B_e = (-2, 0, 0, -2, +2, 0) \bullet B_k = -2 + 0 + 0 - 2 - 2 + 0 = -6$ , i.e. “0”

The following figure shows a sender A that wants to transmit the bits 101. The key of A is shown as signal and binary sequence  $A_k$ . The binary “0” is assigned a positive signal value, the binary “1” a negative signal value. After spreading, i.e., XORing  $A_d$  and  $A_k$ , the resulting signal is  $A_s$ .

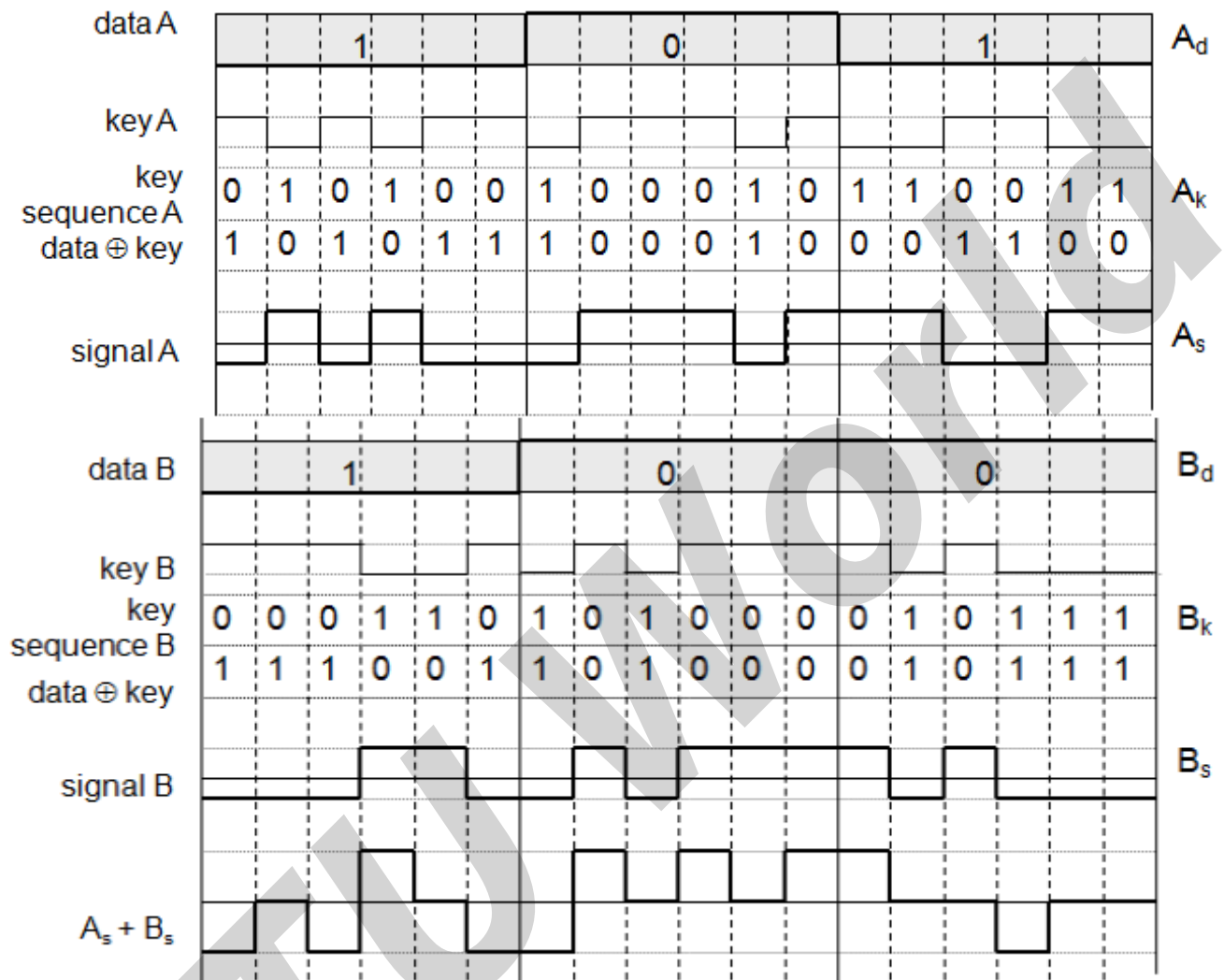

**Coding and spreading of data from sender A and sender B**

The same happens with data from sender B with bits 100. The result is  $B_s$ .  $A_s$  and  $B_s$  now superimpose during transmission. The resulting signal is simply the sum  $A_s + B_s$  as shown above. A now tries to reconstruct the original data from  $A_d$ . The receiver applies A’s key,  $A_k$ , to the received signal and feeds the result into an integrator. The integrator adds the products, a comparator then has to decide if the result is a 0 or a 1 as shown below. As clearly seen, although the original signal form is distorted by B’s signal, the result is quite clear. The same happens if a receiver wants to receive B’s data.

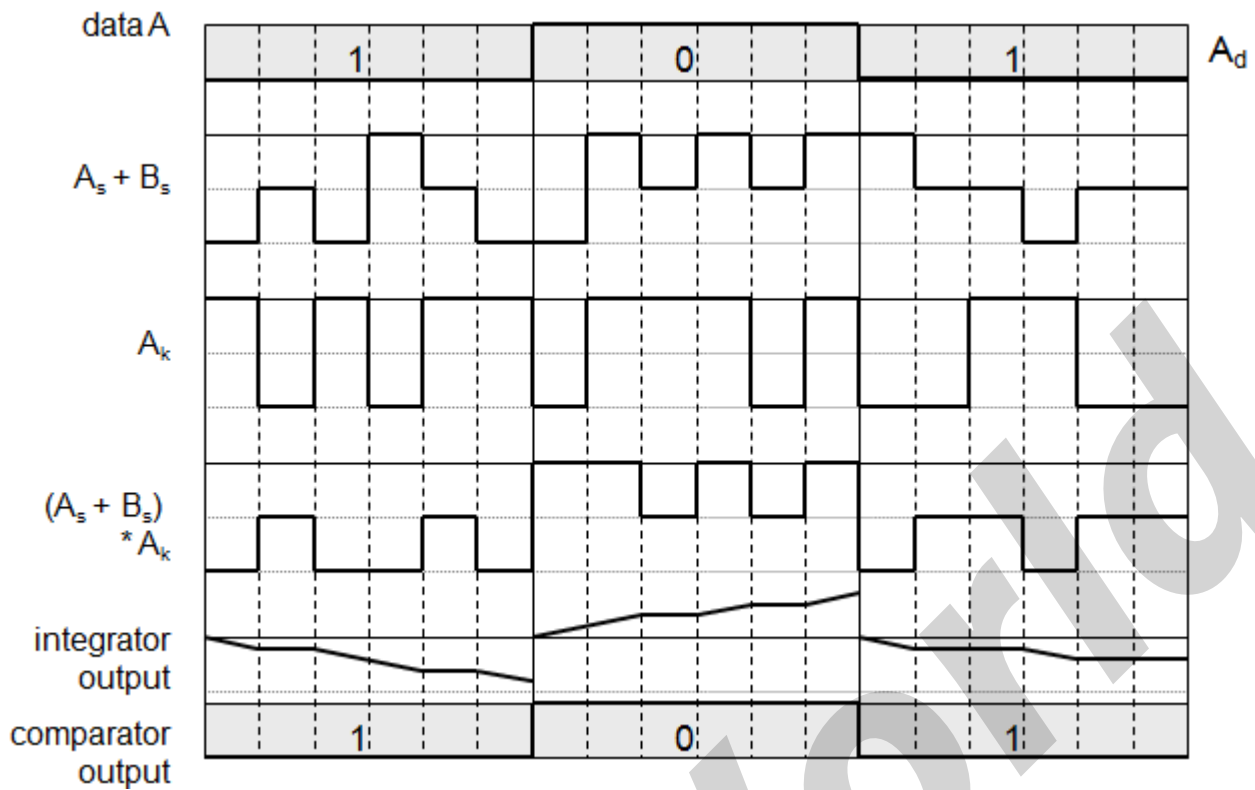

Reconstruction of A's data

**Soft handover** or **soft handoff** refers to a feature used by the CDMA and WCDMA standards, where a cell phone is simultaneously connected to two or more cells (or cell sectors) during a call. If the sectors are from the same physical cell site (a sectorised site), it is referred to as **softer handoff**. This technique is a form of mobile-assisted handover, for IS-95/CDMA2000 CDMA cell phones continuously make power measurements of a list of neighboring cell sites, and determine whether or not to request or end soft handover with the cell sectors on the list.

Soft handoff is different from the traditional hard-handoff process. With hard handoff, a definite decision is made on whether to hand off or not. The handoff is initiated and executed without the user attempting to have simultaneous traffic channel communications with the two base stations. With soft handoff, a *conditional* decision is made on whether to hand off. Depending on the changes in pilot signal strength from the two or more base stations involved, a hard decision will eventually be made to communicate with only one. This normally happens after it is evident that the signal from one base station is considerably stronger than those from the others. In the interim period, the user has simultaneous traffic channel communication with all candidate base stations. It is desirable to implement soft handoff in power-controlled CDMA systems because implementing hard handoff is potentially difficult in such systems.

### Spread Aloha multiple access (SAMA)

CDMA senders and receivers are not really simple devices. Communicating with  $n$  devices requires programming of the receiver to be able to decode  $n$  different codes. Aloha was a very simple scheme, but could only provide a relatively low bandwidth due to collisions. SAMA uses spread spectrum with only one single code (chipping sequence) for spreading for all senders accessing according to aloha.

In SAMA, each sender uses the same spreading code, for ex 110101 as shown below. Sender A and B access the medium at the same time in their narrowband spectrum, so that the three bits shown causes collisions. The same data could also be sent with higher power for shorter periods as show.

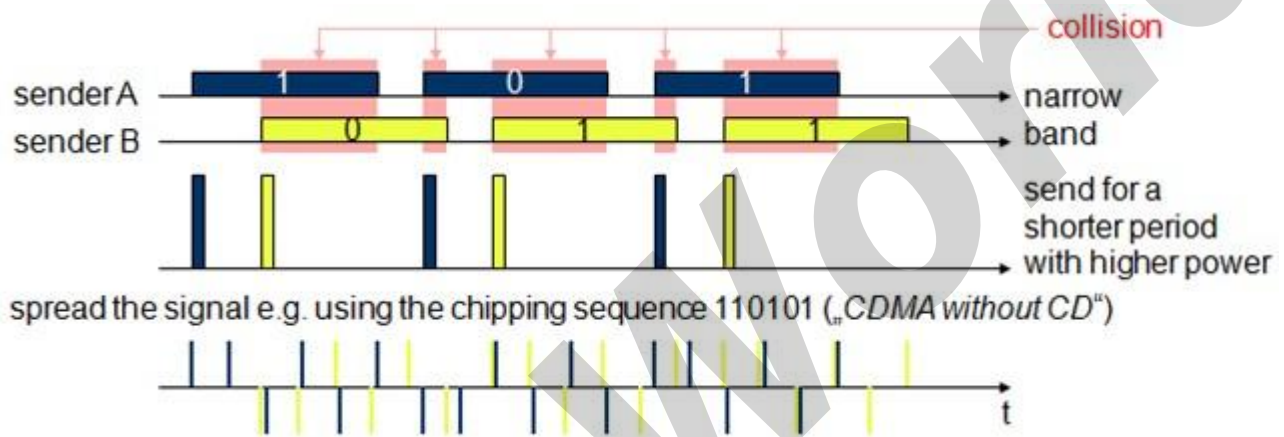

The main problem in using this approach is finding good chipping sequences. The maximum throughput is about 18 per cent, which is very similar to Aloha, but the approach benefits from the advantages of spread spectrum techniques: robustness against narrowband interference and simple coexistence with other systems in the same frequency band.



## UNIT-3

### MOBILE NETWORK LAYER

#### Need for Mobile IP

The IP addresses are designed to work with stationary hosts because part of the address defines the network to which the host is attached. A host cannot change its IP address without terminating on-going sessions and restarting them after it acquires a new address. Other link layer mobility solutions exist but are not sufficient enough for the global Internet.

*Mobility* is the ability of a node to change its point-of-attachment while maintaining all existing communications and using the same IP address.

- *Nomadcity* allows a node to move but it must terminate all existing communications and then can initiate new connections with a new address.

*Mobile IP is a network layer solution for homogenous and heterogeneous mobility on the global Internet which is scalable, robust, secure and which allows nodes to maintain all ongoing communications while moving.*

---

**Design Goals:** Mobile IP was developed as a means for transparently dealing with problems of mobile users. Mobile IP was designed to make the size and the frequency of required routing updates as small as possible. It was designed to make it simple to implement mobile node software. It was designed to avoid solutions that require mobile nodes to use multiple addresses.

**Requirements:** There are several requirements for Mobile IP to make it as a standard. Some of them are:

1. **Compatibility:** The whole architecture of internet is very huge and a new standard cannot introduce changes to the applications or network protocols already in use. Mobile IP is to be integrated into the existing operating systems. Also, for routers also it may be possible to enhance its capabilities to support mobility instead of changing the routers which is highly impossible. Mobile IP must not require special media or MAC/LLC protocols, so it must use the same interfaces and mechanisms to access the lower layers as IP does. Finally, end-systems enhanced with a mobile IP implementation should still be able to communicate with fixed systems without mobile IP.
2. **Transparency:** Mobility remains invisible for many higher layer protocols and applications. Higher layers continue to work even if the mobile computer has

changed its point of attachment to the network and even notice a lower bandwidth and some interruption in the service. As many of today's applications have not been designed to use in mobile environments, the effects of mobility will be higher delay and lower bandwidth.

3. *Scalability and efficiency*: The efficiency of the network should not be affected even if a new mechanism is introduced into the internet. Enhancing IP for mobility must not generate many new messages flooding the whole network. Special care is necessary to be taken considering the lower bandwidth of wireless links. Many mobile systems have a wireless link to an attachment point. Therefore, only some additional packets must be necessary between a mobile system and a node in the network. It is indispensable for a mobile IP to be scalable over a large number of participants in the whole internet, throughout the world.
4. *Security*: Mobility possesses many security problems. A minimum requirement is the authentication of all messages related to the management of mobile IP. It must be sure for the IP layer if it forwards a packet to a mobile host that this host really is the receiver of the packet. The IP layer can only guarantee that the IP address of the receiver is correct. There is no way to prevent faked IP addresses and other attacks.

The goal of a mobile IP can be summarized as: 'supporting end-system mobility while maintaining scalability, efficiency, and compatibility in all respects with existing applications and Internet protocols'.

### **Entities and terminology**

The following defines several entities and terms needed to understand mobile IP as defined in RFC 3344.

- **Mobile Node (MN)**: A mobile node is an end-system or router that can change its point of attachment to the internet using mobile IP. The MN keeps its IP address and can continuously communicate with any other system in the internet as long as link-layer connectivity is given. Examples are laptop, mobile phone, router on an aircraft etc.
- **Correspondent node (CN)**: At least one partner is needed for communication. In the following the CN represents this partner for the MN. The CN can be a fixed or mobile node.
- **Home network**: The home network is the subnet the MN belongs to with respect to its IP address. No mobile IP support is needed within the home network.
- **Foreign network**: The foreign network is the current subnet the MN visits and which is not the home network.

- **Foreign agent (FA):** The FA can provide several services to the MN during its visit to the foreign network. The FA can have the COA, acting as tunnel endpoint and forwarding packets to the MN. The FA can be the default router for the MN. FAs can also provide security services because they belong to the foreign network as opposed to the MN which is only visiting. FA is implemented on a router for the subnet the MN attaches to.
- **Care-of address (COA):** The COA defines the current location of the MN from an IP point of view. All IP packets sent to the MN are delivered to the COA, not directly to the IP address of the MN. Packet delivery toward the MN is done using a tunnel, i.e., the COA marks the tunnel endpoint, i.e., the address where packets exit the tunnel. There are two different possibilities for the location of the COA:

**Foreign agent COA:** The COA could be located at the FA, i.e., the COA is an IP address of the FA. The FA is the tunnel end-point and forwards packets to the MN. Many MN using the FA can share this COA as common COA.

**Co-located COA:** The COA is co-located if the MN temporarily acquired an additional IP address which acts as COA. This address is now topologically correct, and the tunnel endpoint is at the MN. Co-located addresses can be acquired using services such as DHCP.

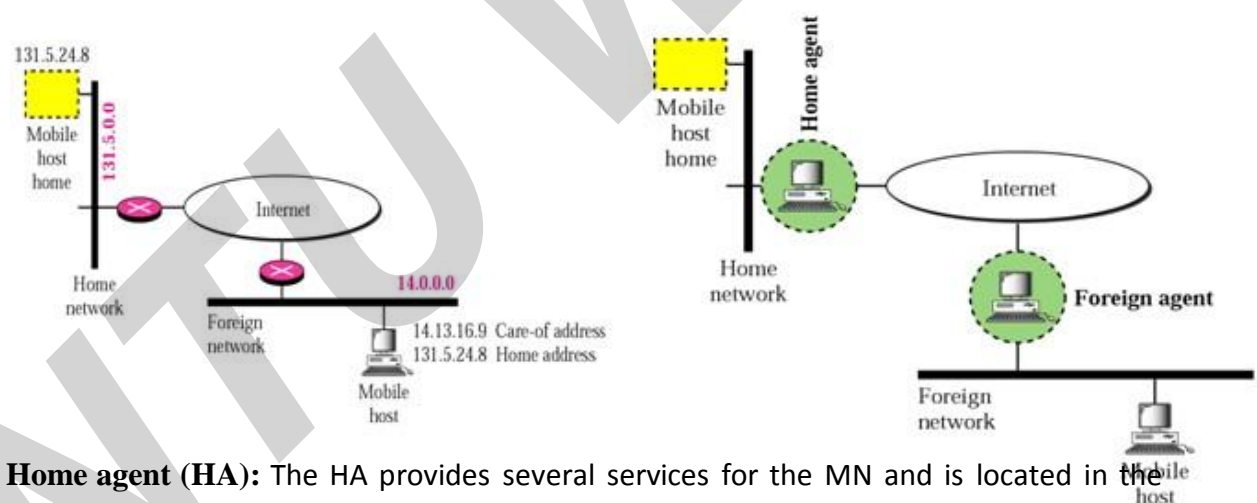

- **Home agent (HA):** The HA provides several services for the MN and is located in the home network. The tunnel for packets toward the MN starts at the HA. The HA maintains a location registry, i.e., it is informed of the MN's location by the current COA. Three alternatives for the implementation of an HA exist.
  1. The HA can be implemented on a router that is responsible for the home network. This is obviously the best position, because without optimizations to mobile IP, all packets for the MN have to go through the router anyway.
  2. If changing the router's software is not possible, the HA could also be implemented on an arbitrary node in the subnet. One disadvantage of this solution is the double

crossing of the router by the packet if the MN is in a foreign network. A packet for the MN comes in via the router; the HA sends it through the tunnel which again crosses the router.

- Finally, a home network is not necessary at all. The HA could be again on the 'router' but this time only acting as a manager for MNs belonging to a virtual home network. All MNs are always in a foreign network with this solution.

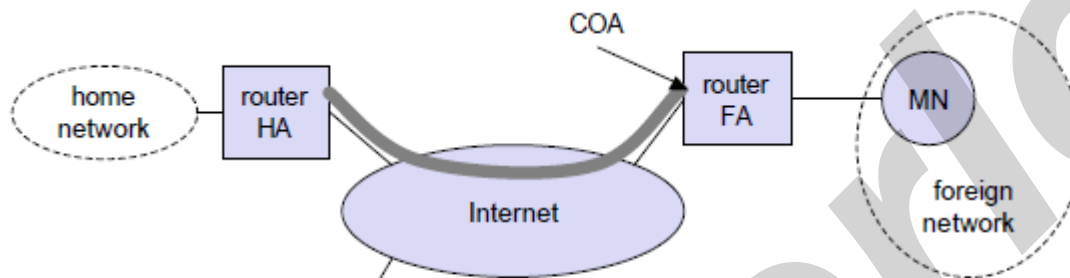

A CN is connected via a router to the internet, as are the home network and the foreign network. The HA is implemented on the router connecting the home network with the internet, an FA is implemented on the router to the foreign network. The MN is currently in the foreign network. The tunnel for packets toward the MN starts at the HA and ends at the FA, for the FA has the COA in the above example.

## IP packet delivery

Consider the above example in which a correspondent node (CN) wants to send an IP packet to the MN. One of the requirements of mobile IP was to support hiding the mobility of the MN. CN does not need to know anything about the MN's current location and sends the packet as usual to the IP address of MN as shown below.

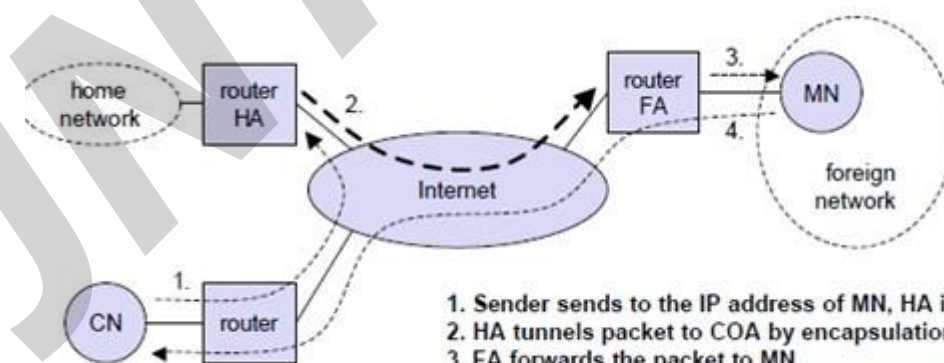

1. Sender sends to the IP address of MN, HA intercepts packet
2. HA tunnels packet to COA by encapsulation
3. FA forwards the packet to MN
4. Reverse: sender sends to IP address of receiver, FA is default router

The internet, not having information on the current location of MN, routes the packet to the router responsible for the home network of MN. This is done using the standard routing

mechanisms of the internet. The HA now intercepts the packet, knowing that MN is currently not in its home network. The packet is not forwarded into the subnet as usual, but encapsulated and tunnelled to the COA. A new header is put in front of the old IP header showing the COA as new destination and HA as source of the encapsulated packet (step 2). The foreign agent now decapsulates the packet, i.e., removes the additional header, and forwards the original packet with CN as source and MN as destination to the MN (step 3). Again, for the MN mobility is not visible. It receives the packet with the same sender and receiver address as it would have done in the home network.

### Data transfer to the mobile system

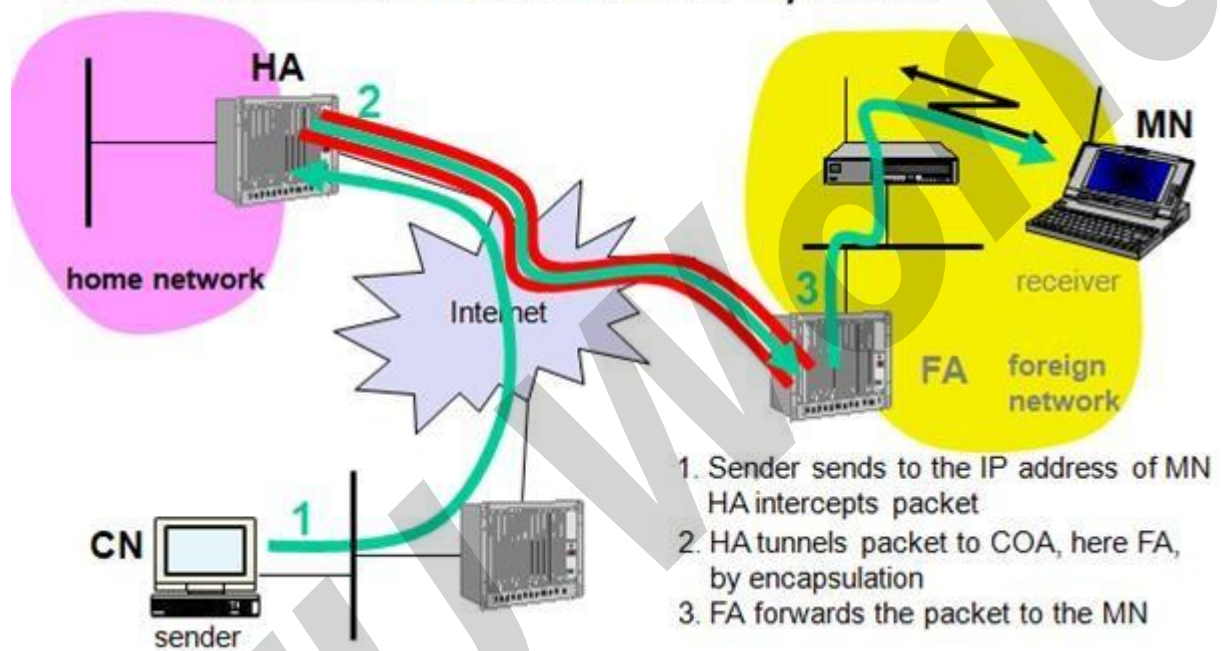

### Data transfer from the mobile system

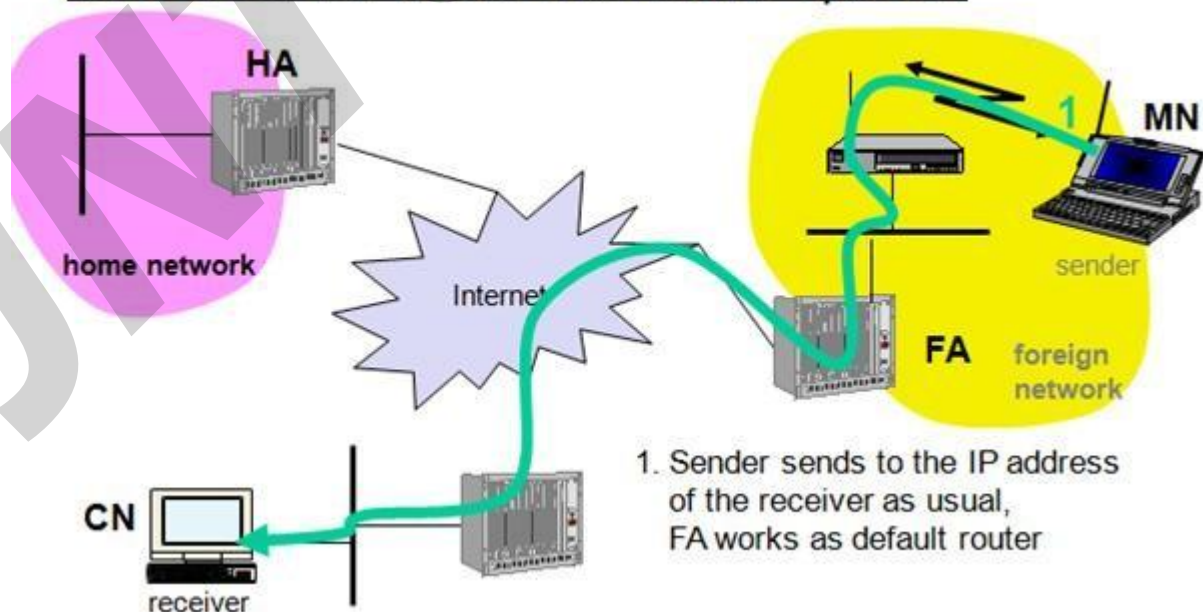

Sending packets from the mobile node (MN) to the CN is comparatively simple. The MN sends the packet as usual with its own fixed IP address as source and CN's address as destination (step 4). The router with the FA acts as default router and forwards the packet in the same way as it would do for any other node in the foreign network. As long as CN is a fixed node the remainder is in the fixed internet as usual. If CN were also a mobile node residing in a foreign network, the same mechanisms as described in steps 1 through 3 would apply now in the other direction.

**Working of Mobile IP:-** Mobile IP has two addresses for a mobile host: one home address and one care-of address. The home address is permanent; the care-of address changes as the mobile host moves from one network to another. To make the change of address transparent to the rest of the Internet requires a home agent and a foreign agent. The specific function of an agent is performed in the application layer. When the mobile host and the foreign agent are the same, the care-of address is called a co-located care-of address. To communicate with a remote host, a mobile host goes through three phases: agent discovery, registration, and data transfer.

## Agent Discovery

A mobile node has to find a foreign agent when it moves away from its home network. To solve this problem, mobile IP describes two methods: agent advertisement and agent solicitation.

### Agent advertisement

For this method, foreign agents and home agents advertise their presence periodically using special **agent advertisement** messages, which are broadcast into the subnet. Mobile IP does not use a new packet type for agent advertisement; it uses the router advertisement packet of ICMP, and appends an agent advertisement message. The agent advertisement packet according to RFC 1256 with the extension for mobility is shown below:

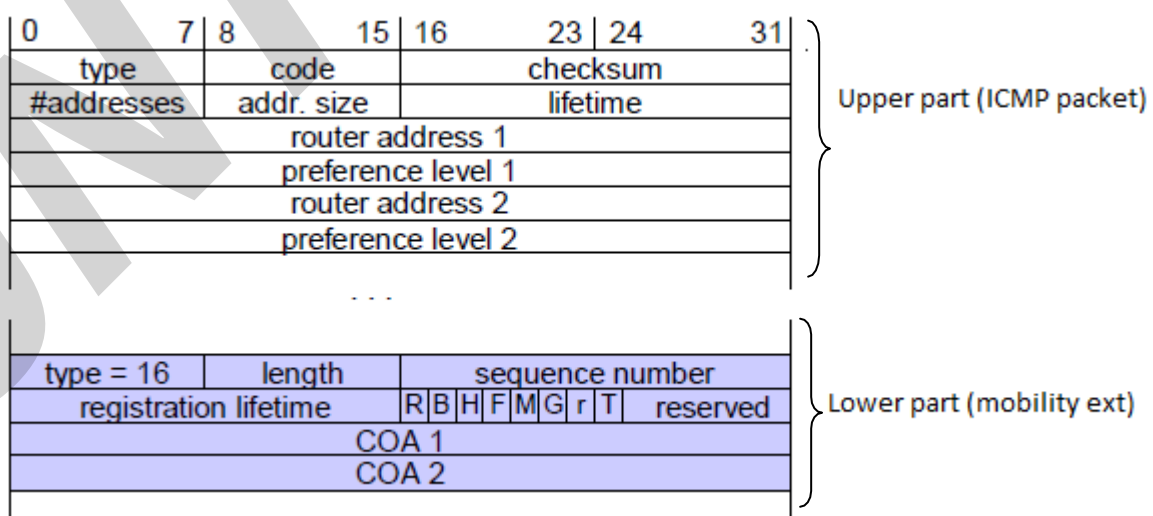

The TTL field of the IP packet is set to 1 for all advertisements to avoid forwarding them. The **type** is set to 9, the **code** can be 0, if the agent also routes traffic from non-mobile nodes, or 16, if it does not route anything other than mobile traffic. The number of addresses advertised with this packet is in **#addresses** while the **addresses** themselves follow as shown. **Lifetime** denotes the length of time this advertisement is valid. **Preference** levels for each address help a node to choose the router that is the most eager one to get a new node.

The extension for mobility has the following fields defined: **type** is set to 16, **length** depends on the number of COAs provided with the message and equals  $6 + 4 * (\text{number of addresses})$ . The **sequence number** shows the total number of advertisements sent since initialization by the agent. By the **registration lifetime** the agent can specify the maximum lifetime in seconds a node can request during registration. The following bits specify the characteristics of an agent in detail.

The **R** bit (registration) shows, if a registration with this agent is required even when using a colocated COA at the MN. If the agent is currently too busy to accept new registrations it can set the **B** bit. The following two bits denote if the agent offers services as a home agent (**H**) or foreign agent (**F**) on the link where the advertisement has been sent. Bits **M** and **G** specify the method of encapsulation used for the tunnel. While IP-in-IP encapsulation is the mandatory standard, **M** can specify minimal encapsulation and **G** generic routing encapsulation. In the first version of mobile IP (RFC 2002) the **V** bit specified the use of header compression according to RFC 1144. Now the field **r** at the same bit position is set to zero and must be ignored. The new field **T** indicates that reverse tunneling is supported by the FA. The following fields contain the **COAs** advertised. A foreign agent setting the **F** bit must advertise at least one COA. A mobile node in a subnet can now receive agent advertisements from either its home agent or a foreign agent. This is one way for the MN to discover its location.

### **Agent Solicitation**

If no agent advertisements are present or the inter-arrival time is too high, and an MN has not received a COA by other means, the mobile node must send **agent solicitations**. Care must be taken to ensure that these solicitation messages do not flood the network, but basically an MN can search for an FA endlessly sending out solicitation messages. If a node does not receive an answer to its solicitations it must decrease the rate of solicitations exponentially to avoid flooding the network until it reaches a maximum interval between solicitations (typically one minute). Discovering a new agent can be done anytime, not just if the MN is not connected to one.

After these steps of advertisements or solicitations the MN can now receive a COA, either one for an FA or a co-located COA.

## Agent Registration

Having received a COA, the MN has to register with the HA. The main purpose of the registration is to inform the HA of the current location for correct forwarding of packets.

Registration can be done in two different ways depending on the location of the COA.

- If the COA is at the FA, the MN sends its registration request containing the COA to the FA which forwards the request to the HA. The HA now sets up a **mobility binding**, containing the mobile node's home IP address and the current COA. It also contains the lifetime of the registration which is negotiated during the registration process. Registration expires automatically after the lifetime and is deleted; so, an MN should reregister before expiration. This mechanism is necessary to avoid mobility bindings which are no longer used. After setting up the mobility binding, the HA sends a reply message back to the FA which forwards it to the MN.

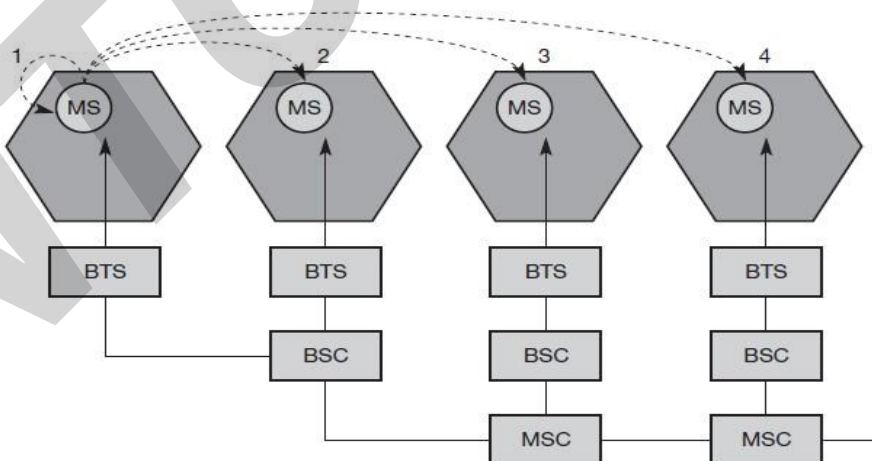

- If the COA is co-located, registration can be simpler, the MN sends the request directly to the HA and vice versa. This is also the registration procedure for MNs returning to their home network to register directly with the HA.



UDP packets are used for the registration requests using the port no 434. The IP source address of the packet is set to the interface address of the MN, the IP destination address is that of the FA or HA.

### Registration Request

The first field **type** is set to 1 for a registration request. With the **S** bit an MN can specify if it wants the HA to retain prior mobility bindings. This allows for simultaneous bindings. Setting the **B** bit generally indicates that an MN also wants to receive the broadcast packets which have been received by the HA in the home network. If an MN uses a co-located COA, it also takes care of the decapsulation at the tunnel endpoint. The **D** bit indicates this behavior. As already defined for agent advertisements, the bits **M** and **G**

Mobile IP

MCUnit-3

DHCP

denote the use of minimal encapsulation or generic routing encapsulation, respectively. **T** indicates reverse tunneling, **r** and **x** are set to zero.

**Lifetime** denotes the validity of the registration in seconds. A value of zero indicates deregistration; all bits set indicates infinity. The **home address** is the fixed IP address of the MN, **home agent** is the IP address of the HA, and **COA** represents the tunnel endpoint. The 64 bit **identification** is generated by the MN to identify a request and match it with registration replies. This field is used for protection against replay attacks of registrations. The **extensions** must at least contain parameters for authentication

A **registration reply**, which is conveyed in a UDP packet, contains a **type** field set to 3 and a **code** indicating the result of the registration request.

### **Registration Reply**

The **lifetime** field indicates how many seconds the registration is valid if it was successful. **Home address** and **home agent** are the addresses of the MN and the HA, respectively. The 64-bit **identification** is used to match registration requests with replies. The value is based on the identification field from the registration and the authentication method. Again, the **extensions** must at least contain parameters for authentication.

## Tunnelling and encapsulation

A **tunnel** establishes a virtual pipe for data packets between a tunnel entry and a tunnel endpoint. Packets entering a tunnel are forwarded inside the tunnel and leave the tunnel unchanged. Tunneling, i.e., sending a packet through a tunnel is achieved by using encapsulation.

### Mobile IP tunnelling

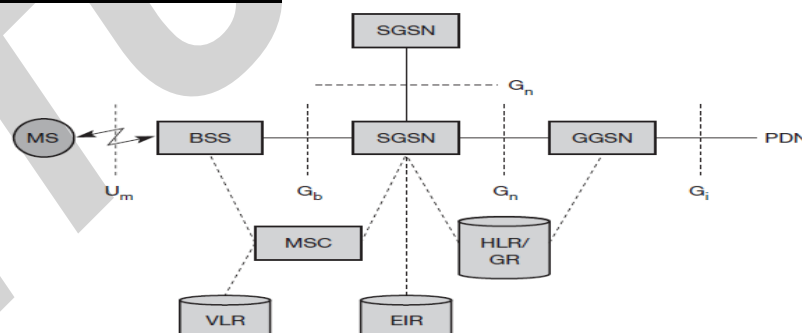

**Encapsulation** is the mechanism of taking a packet consisting of packet header and data and putting it into the data part of a new packet. The reverse operation, taking a packet out of the data part of another packet, is called **decapsulation**. Encapsulation and decapsulation are the operations typically performed when a packet is transferred from a higher protocol layer to a lower layer or from a lower to a higher layer respectively.

The HA takes the original packet with the MN as destination, puts it into the data part of a new packet and sets the new IP header so that the packet is routed to the COA. The new header is called outer header.

**IP-in-IP encapsulation**

There are different ways of performing the encapsulation needed for the tunnel between HA and COA. Mandatory for mobile IP is **IP-in-IP encapsulation** as specified in RFC 2003. The following fig shows a packet inside the tunnel.

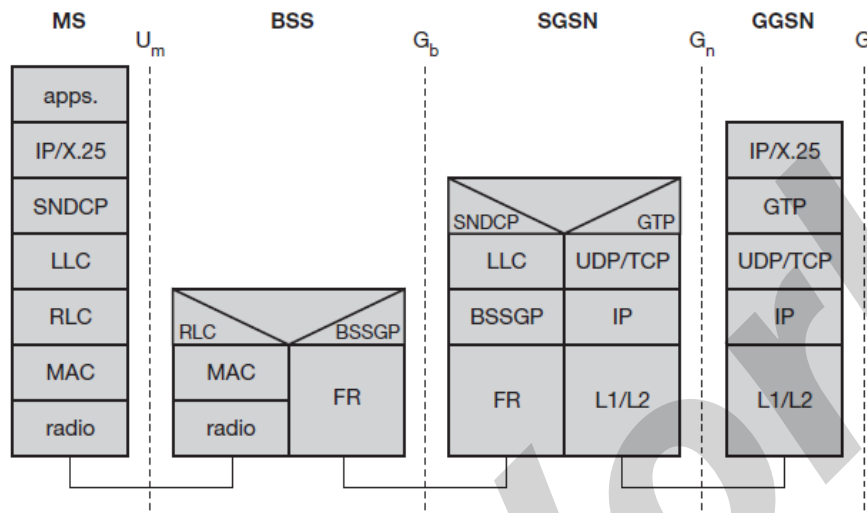

The version field **ver** is 4 for IP version 4, the internet header length (**IHL**) denotes the length of the outer header in 32 bit words. **DS(TOS)** is just copied from the inner header, the **length** field covers the complete encapsulated packet. The fields up to TTL have no special meaning for mobile IP and are set according to RFC 791. **TTL** must be high enough so the packet can reach the tunnel endpoint. The next field, here denoted with **IP-in-IP**, is the type of the protocol used in the IP payload. This field is set to 4, the protocol type for IPv4 because again an IPv4 packet follows after this outer header. **IP checksum** is calculated as usual. The next fields are the tunnel entry as source address (the **IP address of the HA**) and the tunnel exit point as destination address (the **COA**).

If no options follow the outer header, the inner header starts with the same fields as above. This header remains almost unchanged during encapsulation, thus showing the original sender CN and the receiver MN of the packet. The only change is TTL which is decremented by 1. This means that the whole tunnel is considered a single hop from the original packet's point of view. This is a very important feature of tunneling as it allows the MN to behave as if it were attached to the home network. No matter how many real hops the packet has to take in the tunnel, it is just one (logical) hop away for the MN. Finally, the payload follows the two headers.

Mobile IP  
DHCP

MCUnit-3

### **Minimal encapsulation**

Minimal encapsulation (RFC 2004) as shown below is an optional encapsulation method for mobile IP which avoids repetitions of identical fields in IP-in-IP encapsulation. The tunnel entry point and endpoint are specified.

The field for the type of the following header contains the value 55 for the minimal encapsulation protocol. The inner header is different for minimal encapsulation. The type of the following protocol and the address of the MN are needed. If the **S** bit is set, the original sender address of the CN is included as omitting the source is quite often not an option. No field for fragmentation offset is left in the inner header and minimal encapsulation does not work with already fragmented packets.

### **Generic Routing Encapsulation**

Unlike IP-in-IP and Minimal encapsulation which work only for IP packets, **Generic routing encapsulation** (GRE) allows the encapsulation of packets of one protocol suite into the payload portion of a packet of another protocol suite as shown below.

The packet of one protocol suite with the original packet header and data is taken and a new GRE header is prepended. Together this forms the new data part of the new packet. Finally, the header of the second protocol suite is put in front. The following figure shows the fields of a packet inside the tunnel between HA and COA using GRE as an encapsulation scheme according to RFC 1701. The outer header is the standard IP header with HA as

Mobile IP

MCUnit-3

DHCP

source address and COA as destination address. The protocol type used in this outer IP header is 47 for GRE.

The GRE header starts with several flags indicating if certain fields are present or not. A minimal GRE header uses only 4 bytes. The **C** bit indicates if the checksum field is present and contains valid information. If **C** is set, the **checksum** field contains a valid IP checksum of the GRE header and the payload. The **R** bit indicates if the offset and routing fields are present and contain valid information. The **offset** represents the offset in bytes for the first source **routing** entry. The routing field, if present, has a variable length and contains fields for source routing. GRE also offers a **key** field which may be used for authentication. If this field is present, the **K** bit is set. The sequence number bit **S** indicates if the **sequence** number field is present, if the **s** bit is set, strict source routing is used.

The **recursion control** field (rec.) is an important field that additionally distinguishes GRE from IP-in-IP and minimal encapsulation. This field represents a counter that shows the number of allowed recursive encapsulations. The default value of this field should be 0, thus allowing only one level of encapsulation. The following **reserved** fields must be zero and are ignored on reception. The **version** field contains 0 for the GRE version. The following 2 byte **protocol** field represents the protocol of the packet following the GRE header. The standard header of the original packet follows with the source address of the correspondent node and the destination address of the mobile node.

A simplified header of GRE following RFC 2784 is shown below.

The field **C** indicates again if a checksum is present. The next 5 bits are set to zero, then 7 reserved bits follow. The **version** field contains the value zero. The **protocol** type, again, defines the protocol of the payload following RFC 3232. If the flag **C** is set, then **checksum** field and a field called reserved1 follows. The latter field is constant zero set to zero follow.

## Optimizations

If a scenario occurs, where if the MN is in the same subnetwork as the node to which it is communicating and HA is on the other side of the world. It is called triangular routing problem as it causes unnecessary overheads for the network between CN and the HA.

A solution to this problem is to inform the CN of the current location of the MN. The CN can learn the location by caching it in a binding cache, which is a part of the routing table for the CN. HA informs the CN of the location. It needs four additional messages:

- **Binding Request:** It is sent by the node that wants to know the current location of an MN to the HA. HA checks if it is allowed to reveal the location and then sends back a binding update
- **Binding update:** It is sent by the HA to the CN revealing the current location of an MN. It contains the fixed IP address of the MN and the COA. This message can request an acknowledgement.

Mobile IP

MCUnit-3

DHCP

- **Binding acknowledgement:** If requested, a node returns this acknowledgement after receiving a binding update message
- **Binding warning:** A node sends a binding warning if it decapsulates a packet for an MN, but it is not the current FA of this MN. It contains MN's home address and a target node's address. The recipient can be the HA, so the HA now sends a binding update to the node that obviously has a wrong COA for the MN.

The following figure shows how the four additional messages are used together if an MN changes its FA.

The CN can request the current location from the HA. If allowed by the MN, the HA returns the COA of the MN via an update message. The CN acknowledges this update message and stores the mobility binding. Now the CN can send its data directly to the current foreign agent  $FA_{old}$ .  $FA_{old}$  forwards the packets to the MN. This scenario shows a COA located at an FA. Encapsulation of data for tunneling to the COA is now done by the CN, not the HA.

The MN might now change its location and register with a new foreign agent,  $FA_{new}$ . This registration is also forwarded to the HA to update its location database. Furthermore,  $FA_{new}$  informs  $FA_{old}$  about the new registration of MN. MN's registration message contains the address of  $FA_{old}$  for this purpose. Passing this information is achieved via an update message, which is acknowledged by  $FA_{old}$ .



Without the information provided by the new FA, the old FA would not get to know anything about the new location of MN. In this case, CN does not know anything about the new location, so it still tunnels its packets for MN to the old FA, FA<sub>old</sub>. This FA now notices packets with destination MN, but also knows that it is not the current FA of MN. FA<sub>old</sub> might now forward these packets to the new COA of MN which is FA<sub>new</sub> in this example. This forwarding of packets is another optimization of the basic Mobile IP providing **smooth handovers**. Without this optimization, all packets in transit would be lost while the MN moves from one FA to another.

To tell CN that it has a stale binding cache, FA<sub>old</sub> sends, a binding warning message to CN. CN then requests a binding update. (The warning could also be directly sent to the HA triggering an update). The HA sends an update to inform the CN about the new location, which is acknowledged. Now CN can send its packets directly to FA<sub>new</sub>, again avoiding triangular routing. Unfortunately, this optimization of mobile IP to avoid triangular routing causes several security problems

## Reverse Tunnelling

The reverse path from MS to the CN looks quite simple as the MN can directly send its packets to the CN as in any other standard IP situation. The destination address in the packets is that of CN. But it has some problems explained below:-

- Quite often firewalls are designed to only allow packets with topologically correct addresses to pass to provide simple protection against misconfigured systems of unknown addresses. However, MN still sends packets with its fixed IP address as source which is not topologically correct in a foreign network. Firewalls often filter packets coming from outside containing a source address from computers of the internal network. This also implies that an MN cannot send a packet to a computer residing in its home network.
- While the nodes in the home network might participate in a multi-cast group, an MN in a foreign network cannot transmit multi-cast packets in a way that they emanate from its home network without a reverse tunnel. The foreign network might not even provide the technical infrastructure for multi-cast communication (multi-cast backbone, Mbone).
- If the MN moves to a new foreign network, the older TTL might be too low for the packets to reach the same destination nodes as before. Mobile IP is no longer transparent if a user has to adjust the TTL while moving. A reverse tunnel is needed that represents only one hop, no matter how many hops are really needed from the foreign to the home network

Based on the above considerations, reverse tunnelling is defined as an extension to mobile IP (per RFC 2344). It was designed backward compatible to mobile IP and defines topologically correct reverse tunnelling to handle the above stated problems.

### Reverse Tunnelling

#### Packet Forwarding

#### Reverse Tunnel

Reverse tunneling does not solve

- ❖ problems with *firewalls*, the reverse tunnel can be abused to circumvent security mechanisms (tunnel hijacking)
- ❖ optimization of data paths, i.e. packets will be forwarded through the tunnel via the HA to a sender (double triangular routing)

Mobile IP

MCUnit-3

DHCP

## IPv6

The design of Mobile IP support in IPv6 (Mobile IPv6) benefits both from the experiences gained from the development of Mobile IP support in IPv4, and from the opportunities provided by IPv6. Mobile IPv6 thus shares many features with Mobile IPv4, but is integrated into IPv6 and offers many other improvements. This section summarizes the major differences between Mobile IPv4 and Mobile IPv6:

- There is no need to deploy special routers as "foreign agents", as in Mobile IPv4. Mobile IPv6 operates in any location without any special support required from the local router.
- Support for route optimization is a fundamental part of the protocol, rather than a nonstandard set of extensions.
- Mobile IPv6 route optimization can operate securely even without pre-arranged security associations. It is expected that route optimization can be deployed on a global scale between all mobile nodes and correspondent nodes.
- Support is also integrated into Mobile IPv6 for allowing route optimization to coexist efficiently with routers that perform "ingress filtering"
- The IPv6 Neighbor Unreachability Detection assures symmetric reachability between the mobile node and its default router in the current location.
- Most packets sent to a mobile node while away from home in Mobile IPv6 are sent using an IPv6 routing header rather than IP encapsulation, reducing the amount of resulting overhead compared to Mobile IPv4.
- Mobile IPv6 is decoupled from any particular link layer, as it uses IPv6 Neighbor Discovery instead of ARP. This also improves the robustness of the protocol.
- The use of IPv6 encapsulation (and the routing header) removes the need in Mobile IPv6 to manage "tunnel soft state".
- The dynamic home agent address discovery mechanism in Mobile IPv6 returns a single reply to the mobile node. The directed broadcast approach used in IPv4 returns separate replies from each home agent.

## Dynamic Host Configuration Protocol (DHCP)

**DHCP** is an automatic configuration protocol used on IP networks. **DHCP** allows a computer to join an IP-based network without having a pre-configured IP address. DHCP is a protocol that assigns unique IP addresses to devices, then releases and renews these addresses as devices leave and re-join the network. If a new computer is connected to a network, DHCP can provide it with all the necessary information for full system integration into the network, e.g., addresses of a DNS server and the default router, the subnet mask, the domain name, and an IP address. Providing an IP address makes DHCP very attractive for mobile IP as a source of care-of-addresses.

Mobile IP  
DHCP

## MCUnit-3

DHCP is based on a client/server model as shown below. DHCP clients send a request to a server (DHCPDISCOVER in the example) to which the server responds. A client sends requests using MAC broadcasts to reach all devices in the LAN. A DHCP relay might be needed to forward requests across inter-working units to a DHCP server.

Consider the scenario where there is one client and two servers are present. A typical initialization of a DHCP client is shown below:

the client broadcasts a DHCPDISCOVER into the subnet. There might be a relay to forward this broadcast. In the case shown, two servers receive this broadcast and determine the configuration they can offer to the client. Servers reply to the client's request with DHCPOFFER and offer a list of configuration parameters. The client can now choose one of the configurations offered. The client in turn replies to the servers, accepting one of the configurations and rejecting the others using DHCPREQUEST. If a server receives a DHCPREQUEST with a rejection, it can free the reserved configuration for other possible

## Mobile IP DHCP

MCUnit-3

clients. The server with the configuration accepted by the client now confirms the configuration with DHCPACK. This completes the initialization phase. If a client leaves a subnet, it should release the configuration received by the server using DHCPRELEASE. Now the server can free the context stored for the client and offer the configuration again. The configuration a client gets from a server is only leased for a certain amount of time, it has to be reconfirmed from time to time. Otherwise the server will free the configuration. This timeout of configuration helps in the case of crashed nodes or nodes moved away without releasing the context.

DHCP is a good candidate for supporting the acquisition of care-of addresses for mobile nodes. The same holds for all other parameters needed, such as addresses of the default router, DNS servers, the timeserver etc. A DHCP server should be located in the subnet of the access point of the mobile node, or at least a DHCP relay should provide forwarding of the messages. RFC 3118 specifies authentication for DHCP messages so as to provide protection from malicious DHCP servers. Without authentication, a DHCP server cannot trust the mobile node and vice versa...

---

JNTU World

## Unit-4

# Traditional TCP

The **Transmission Control Protocol (TCP)** is one of the core protocols of the Internet protocol suite, often simply referred to as TCP/IP. TCP is reliable, guarantees in-order delivery of data and incorporates congestion control and flow control mechanisms.

The five-layer TCP/IP model
<b>5. Application layer</b>
DHCP • DNS • FTP • Gopher • HTTP • IMAP4 • IRC • NNTP • XMPP • MIME • POP3 • SIP • SMTP • SNMP • SSH • TELNET • RPC • RTP • RTCP • TLS/SSL • SDP • SOAP • VPN • PPTP • L2TP • GTP • ...
<b>4. Transport layer</b>
TCP • UDP • DCCP • SCTP • ...
<b>3. Internet layer</b>
IP (IPv4 • IPv6) • IGMP • ICMP • RSVP • BGP • RIP • OSPF • ISIS • IPsec • ARP • RARP • ...
<b>2. Data link layer</b>
802.11 • ATM • DTM • Ethernet • FDDI • Frame Relay • GPRS • EVDO • HSPA • HDLC • PPP • ...
<b>1. Physical layer</b>
Ethernet physical layer • ISDN • Modems • PLC • SONET/SDH • G.709 • WiMAX • ...

TCP supports many of the Internet's most popular application protocols and resulting applications, including the World Wide Web, e-mail, File Transfer Protocol and Secure Shell. In the Internet protocol suite, TCP is the intermediate layer between the Internet layer and application layer.

The major responsibilities of TCP in an active session are to:

- **Provide reliable in-order transport of data:** to not allow losses of data.
- **Control congestions in the networks:** to not allow degradation of the network performance,
- **Control a packet flow between the transmitter and the receiver:** to not exceed the receiver's capacity.

TCP uses a number of mechanisms to achieve high performance and avoid 'congestion collapse', where network performance can fall by several orders of magnitude. These mechanisms control the rate of data entering the network, keeping the data flow below a rate that would trigger collapse. There are several mechanisms of TCP that influence the efficiency of TCP in a mobile environment. Acknowledgments for data sent, or lack of acknowledgments, are used by senders to implicitly interpret network conditions between the TCP sender and receiver.

# Congestion Control

A transport layer protocol such as TCP has been designed for fixed networks with fixed end- systems. Congestion may appear from time to time even in carefully designed networks. The packet buffers of a router are filled and the router cannot forward the packets fast enough because the sum of the input rates of packets destined for one output link is higher than the capacity of the output link. The only thing a router can do in this situation is to drop packets. A dropped packet is lost for the transmission, and the receiver notices a gap in the packet stream. Now the receiver does not directly tell the sender which packet is missing, but continues to acknowledge all in-sequence packets up to the missing one.

The sender notices the missing acknowledgement for the lost packet and assumes a packet loss due to congestion. Retransmitting the missing packet and continuing at full sending rate would now be unwise, as this might only increase the congestion. To mitigate congestion, TCP slows down the transmission rate dramatically. All other TCP connections experiencing the same congestion do exactly the same so the congestion is soon resolved.

## Slow start

TCP's reaction to a missing acknowledgement is quite drastic, but it is necessary to get rid of congestion quickly. The behavior TCP shows after the detection of congestion is called **slow start**. The sender always calculates a **congestion window** for a receiver. The start size of the congestion window is one segment (TCP packet). The sender sends one packet and waits for acknowledgement. If this acknowledgement arrives, the sender increases the congestion window by one, now sending two packets (congestion window = 2). This scheme doubles the congestion window every time the acknowledgements come back, which takes one round trip time (RTT). This is called the exponential growth of the congestion window in the slow start mechanism.

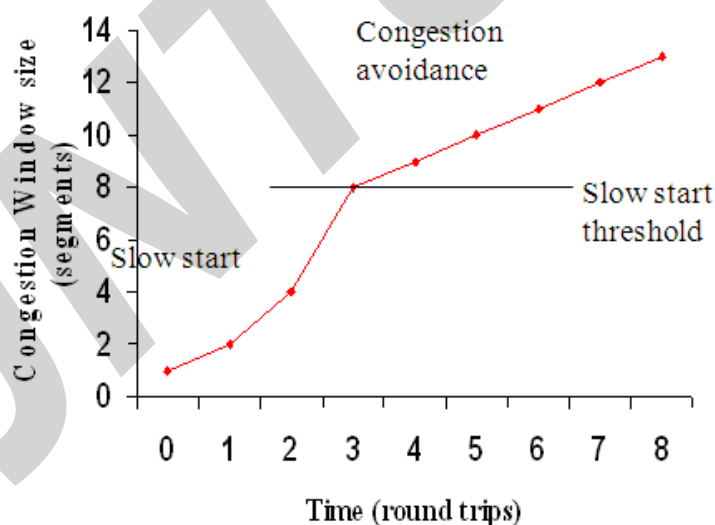

But doubling the congestion window is too dangerous. The exponential growth stops at the **congestion threshold**. As soon as the congestion window reaches the congestion threshold, further increase of the transmission rate is only linear by adding 1 to the congestion window each time the acknowledgements come back.



## Mobile Transport Layer Unit-4

Mobile Computing

Linear increase continues until a time-out at the sender occurs due to a missing acknowledgement, or until the sender detects a gap in transmitted data because of continuous acknowledgements for the same packet. In either case the sender sets the congestion threshold to half of the current congestion

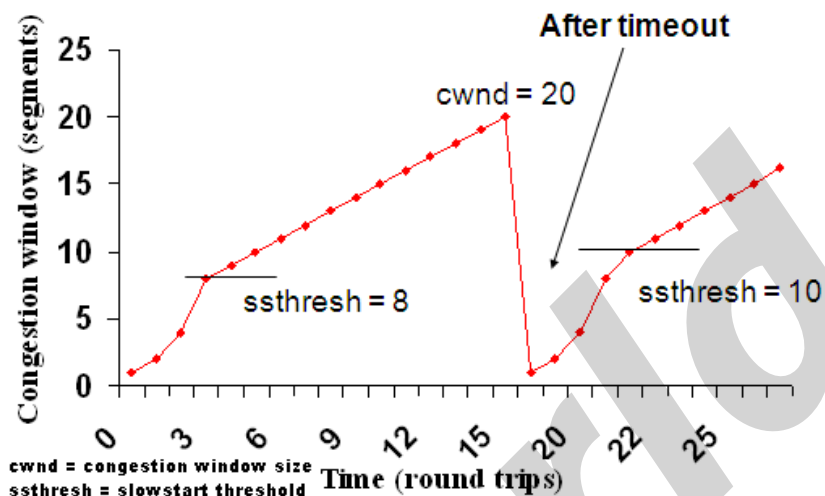

window. The congestion window itself is set to one segment and the sender starts sending a single segment. The exponential growth starts once more up to the new congestion threshold, then the window grows in linear fashion.

### Fast retransmit/fast recovery

The congestion threshold can be reduced because of two reasons. First one is if the sender receives continuous acknowledgements for the same packet. It informs the sender that the receiver has got all the packets upto the acknowledged packet in the sequence and also the receiver is receiving something continuously from the sender. The gap in the packet stream is not due to congestion, but a simple packet loss due to a transmission error. The sender can now retransmit the missing packet(s) before the timer expires. This behavior is called **fast retransmit**. It is an early enhancement for preventing slow-start to trigger on losses not caused by congestion. The receipt of acknowledgements shows that there is no congestion to justify a slow start. The sender can continue with the current congestion window. The sender performs a **fast recovery** from the packet loss. This mechanism can improve the efficiency of TCP dramatically. The other reason for activating slow start is a time-out due to a missing acknowledgement. TCP using fast retransmit/fast recovery interprets this congestion in the network and activates the slow start mechanism.

- The advantage of this method is its simplicity. Minor changes in the MH's software results in performance increase. No changes are required in FA or CH.
- The disadvantage of this scheme is insufficient isolation of packet losses. It mainly focuses on problems regarding Handover. Also it effects the efficiency when a CH transmits already delivered packets.

## Problems with Traditional TCP in wireless environments

- Slow Start mechanism in fixed networks decreases the efficiency of TCP if used with mobile receivers or senders.
- Error rates on wireless links are orders of magnitude higher compared to fixed fiber or copper links. This makes compensation for packet loss by TCP quite difficult.
- Mobility itself can cause packet loss. There are many situations where a soft handover from one access point to another is not possible for a mobile end-system.
- Standard TCP reacts with slow start if acknowledgements are missing, which does not help in the case of transmission errors over wireless links and which does not really help during handover. This behavior results in a severe performance degradation of an unchanged TCP if used together with wireless links or mobile nodes

## Classical TCP Improvements

### Indirect TCP (I-TCP)

Indirect TCP segments a TCP connection into a fixed part and a wireless part. The following figure shows an example with a mobile host connected via a wireless link and an access point to the 'wired' internet where the correspondent host resides.

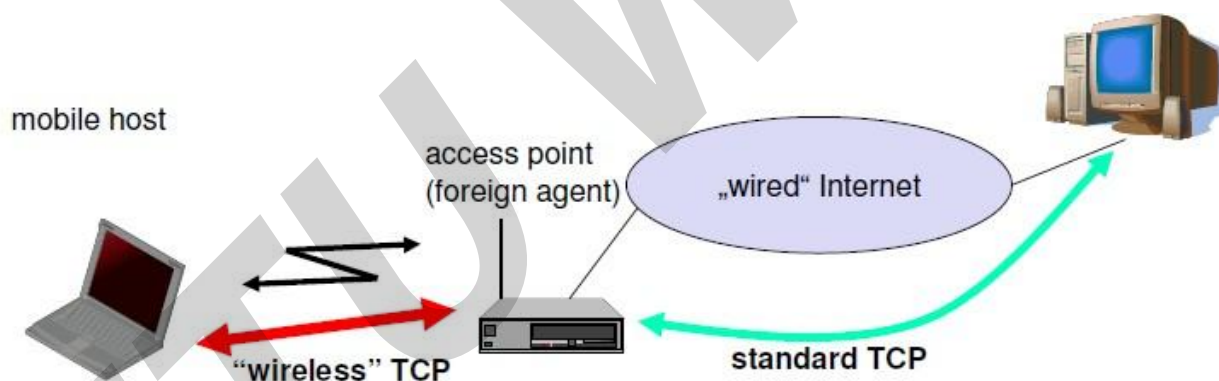

Standard TCP is used between the fixed computer and the access point. No computer in the internet recognizes any changes to TCP. Instead of the mobile host, the access point now terminates the standard TCP connection, acting as a proxy. This means that the access point is now seen as the mobile host for the fixed host and as the fixed host for the mobile host. Between the access point and the mobile host, a special TCP, adapted to wireless links, is used. However, changing TCP for the wireless link is not a requirement. A suitable place for segmenting the connection is at the foreign agent as it not only controls the mobility of the mobile host anyway and can also hand over the connection to the next foreign agent when the mobile host moves on.

The foreign agent acts as a proxy and relays all data in both directions. If CH (correspondent host) sends a packet to the MH, the FA acknowledges it and forwards it to the MH. MH acknowledges on successful reception, but this is only used by the FA. If a packet is lost on the wireless link, CH doesn't observe it and FA tries to retransmit it locally to maintain reliable data transport. If the MH sends a packet, the FA acknowledges it and forwards it to CH. If the packet is lost on the wireless link, the mobile hosts notice this much faster due to the lower round trip time and can directly retransmit the packet. Packet loss in the wired network is now handled by the foreign agent.

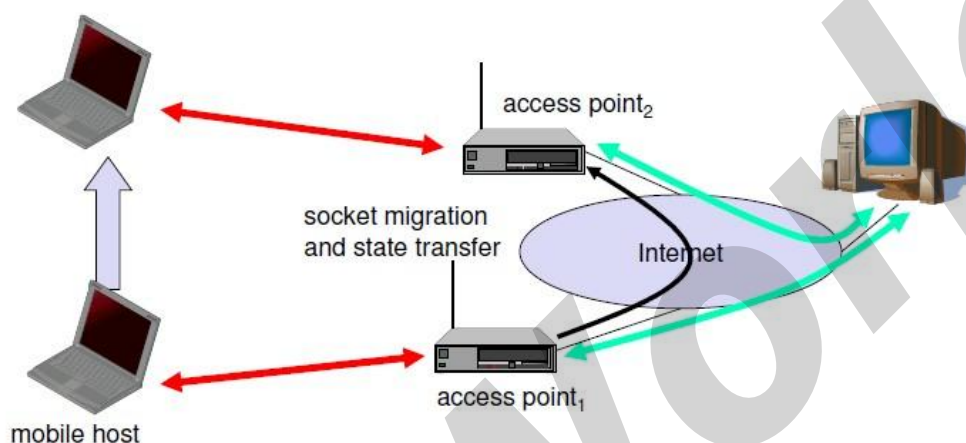

### Socket and state migration after handover of a mobile host

During handover, the buffered packets, as well as the system state (packet sequence number, acknowledgements, ports, etc), must migrate to the new agent. No new connection may be established for the mobile host, and the correspondent host must not see any changes in connection state. Packet delivery in I-TCP is shown below:

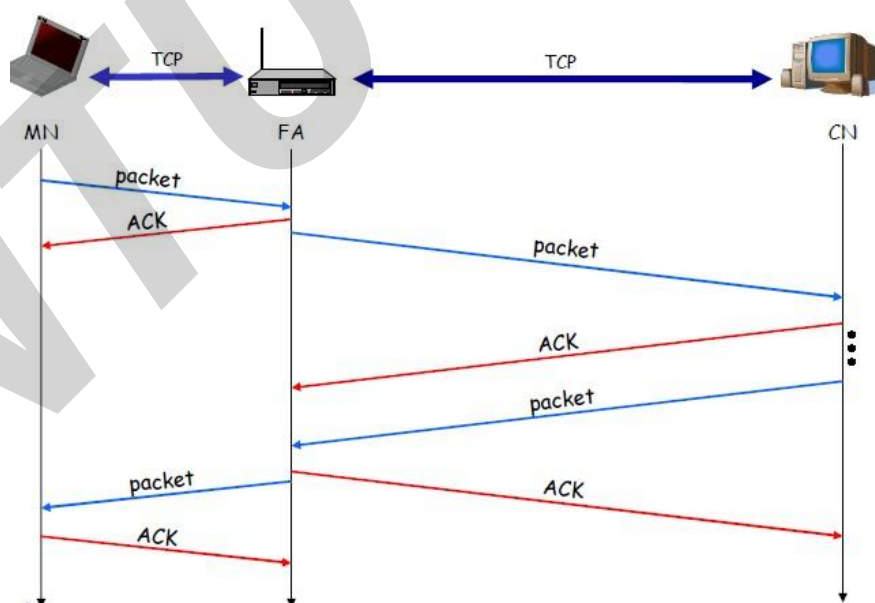

### *Advantages of I-TCP*

- No changes in the fixed network necessary, no changes for the hosts (TCP protocol) necessary, all current optimizations to TCP still work
- Simple to control, mobile TCP is used only for one hop between, e.g., a foreign agent and mobile host
  1. transmission errors on the wireless link do not propagate into the fixed network
  2. therefore, a very fast retransmission of packets is possible, the short delay on the mobile hops known
- It is always dangerous to introduce new mechanisms in a huge network without knowing exactly how they behave.
  - ❖ New optimizations can be tested at the last hop, without jeopardizing the stability of the Internet.
- It is easy to use different protocols for wired and wireless networks.

### *Disadvantages of I-TCP*

- Loss of end-to-end semantics:- an acknowledgement to a sender no longer means that a receiver really has received a packet, foreign agents might crash.
- Higher latency possible:- due to buffering of data within the foreign agent and forwarding to a new foreign agent
- Security issue:- The foreign agent must be a trusted entity

### **Snooping TCP**

The main drawback of I-TCP is the segmentation of the single TCP connection into two TCP connections, which loses the original end-to-end TCP semantic. A new enhancement, which leaves the TCP connection intact and is completely transparent, is Snooping TCP. The main function is to buffer data close to the mobile host to perform fast local retransmission in case of packet loss.

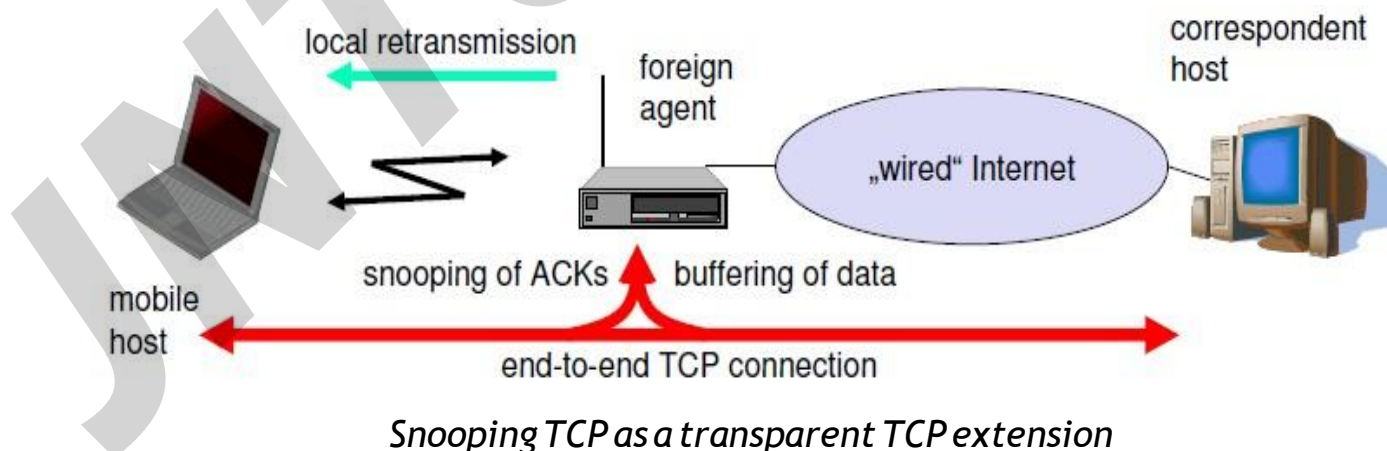

Here, the foreign agent buffers all packets with **destination mobile host** and additionally 'snoops' the packet flow in both directions to recognize acknowledgements. The foreign agent buffers every packet until it receives an acknowledgement from the mobile host. If the FA does not receive an acknowledgement from the mobile host within a certain amount of time, either the packet or the acknowledgement has been lost. Alternatively, the foreign agent could receive a duplicate ACK which also shows the loss of a packet. Now, the FA retransmits the packet directly from the buffer thus performing a faster retransmission compared to the CH. For transparency, the FA does not acknowledge data to the CH, which would violate end-to-end semantic in case of a FA failure. The foreign agent can filter the duplicate acknowledgements to avoid unnecessary retransmissions of data from the correspondent host. If the foreign agent now crashes, the time-out of the correspondent host still works and triggers a retransmission. The foreign agent may discard duplicates of packets already retransmitted locally and acknowledged by the mobile host. This avoids unnecessary traffic on the wireless link.

For data transfer from the mobile host with **destination correspondent host**, the FA snoops into the packet stream to detect gaps in the sequence numbers of TCP. As soon as the foreign agent detects a missing packet, it returns a negative acknowledgement (NACK) to the mobile host. The mobile host can now retransmit the missing packet immediately. Reordering of packets is done automatically at the correspondent host by TCP.

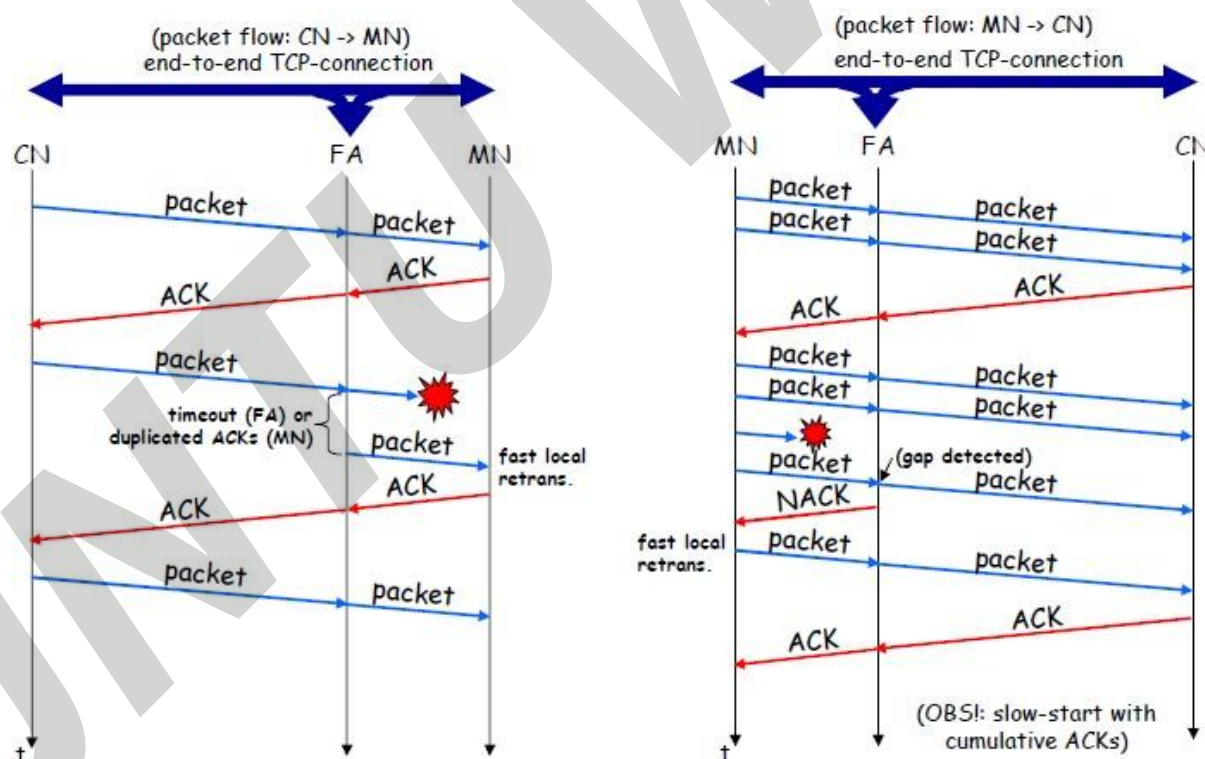

*Snooping TCP: Packet delivery*

### Advantages of snooping TCP:

- The end-to-end TCP semantic is preserved.
- Most of the enhancements are done in the foreign agent itself which keeps correspondent host unchanged.
- Handover of state is not required as soon as the mobile host moves to another foreign agent. Even though packets are present in the buffer, time out at the CH occurs and the packets are transmitted to the new COA.
- No problem arises if the new foreign agent uses the enhancement or not. If not, the approach automatically falls back to the standard solution.

### Disadvantages of snooping TCP

- Snooping TCP does not isolate the behavior of the wireless link as well as I-TCP. Transmission errors may propagate till CH.
- Using negative acknowledgements between the foreign agent and the mobile host assumes additional mechanisms on the mobile host. This approach is no longer transparent for arbitrary mobile hosts.
- Snooping and buffering data may be useless if certain encryption schemes are applied end-to-end between the correspondent host and mobile host. If encryption is used above the transport layer, (eg. SSL/TLS), snooping TCP can be used.

### Mobile TCP

Both I-TCP and Snooping TCP does not help much, if a mobile host gets disconnected. The **M-TCP (mobile TCP)** approach has the same goals as I-TCP and snooping TCP: to prevent the sender window from shrinking if bit errors or disconnection but not congestion cause current problems. M-TCP wants to improve overall throughput, to lower the delay, to maintain end-to-end semantics of TCP, and to provide a more efficient handover. Additionally, M-TCP is especially adapted to the problems arising from lengthy or frequent disconnections. M-TCP splits the TCP connection into two parts as I-TCP does. An unmodified TCP is used on the standard host-**supervisory host (SH)** connection, while an optimized TCP is used on the SH-MH connection.

The SH monitors all packets sent to the MH and ACKs returned from the MH. If the SH does not receive an ACK for some time, it assumes that the MH is disconnected. It then chokes the sender by setting the sender's window size to 0. Setting the window size to 0 forces the sender to go into **persistent mode**, i.e., the state of the sender will not change no matter how long the receiver is disconnected. This means that the sender will not try to retransmit data. As soon as the SH (either the old SH or a new SH) detects connectivity again, it reopens the window of the sender to the old value. The sender can continue sending at full speed. This mechanism does not require changes to the sender's TCP. The wireless side uses an adapted



TCP that can recover from packet loss much faster. This modified TCP does not use slow start, thus, M-TCP needs a **bandwidth manager** to implement fair sharing over the wireless link.

#### Advantages of M-TCP:

- It maintains the TCP end-to-end semantics. The SH does not send any ACK itself but forwards the ACKs from the MH.
- If the MH is disconnected, it avoids useless retransmissions, slow starts or breaking connections by simply shrinking the sender's window to 0.
- As no buffering is done as in I-TCP, there is no need to forward buffers to a new SH. Lost packets will be automatically retransmitted to the SH.

#### Disadvantages of M-TCP:

- As the SH does not act as proxy as in I-TCP, packet loss on the wireless link due to bit errors is propagated to the sender. M-TCP assumes low bit error rates, which is not always a valid assumption.
- A modified TCP on the wireless link not only requires modifications to the MH protocol software but also new network elements like the bandwidth manager.

#### Transmission/time-out freezing

Often, MAC layer notices connection problems even before the connection is actually interrupted from a TCP point of view and also knows the real reason for the interruption. The MAC layer can inform the TCP layer of an upcoming loss of connection or that the current interruption is not caused by congestion. TCP can now stop sending and 'freezes' the current state of its congestion window and further timers. If the MAC layer notices the upcoming interruption early enough, both the mobile and correspondent host can be informed. With a fast interruption of the wireless link, additional mechanisms in the access point are needed to inform the correspondent host of the reason for interruption. Otherwise, the correspondent host goes into slow start assuming congestion and finally breaks the connection.

As soon as the MAC layer detects connectivity again, it signals TCP that it can resume operation at exactly the same point where it had been forced to stop. For TCP time simply does not advance, so no timers expire.

#### Advantages:

- It offers a way to resume TCP connections even after long interruptions of the connection.
- It can be used together with encrypted data as it is independent of other TCP mechanisms such as sequence no or acknowledgements

#### Disadvantages:

- Lots of changes have to be made in software of MH, CH and FA.

### Selective retransmission

A very useful extension of TCP is the use of selective retransmission. TCP acknowledgements are cumulative, i.e., they acknowledge in-order receipt of packets up to a certain packet. A single acknowledgement confirms reception of all packets upto a certain packet. If a single packet is lost, the sender has to retransmit everything starting from the lost packet (go-back-n retransmission). This obviously wastes bandwidth, not just in the case of a mobile network, but for any network.

Using selective retransmission, TCP can indirectly request a selective retransmission of packets. The receiver can acknowledge single packets, not only trains of in-sequence packets. The sender can now determine precisely which packet is needed and can retransmit it. The **advantage** of this approach is obvious: a sender retransmits only the lost packets. This lowers bandwidth requirements and is extremely helpful in slow wireless links. The disadvantage is that a more complex software on the receiver side is needed. Also more buffer space is needed to resequence data and to wait for gaps to be filled.

### Transaction-oriented TCP

Assume an application running on the mobile host that sends a short request to a server from time to time, which responds with a short message and it requires reliable TCP transport of the packets. For it to use normal TCP, it is inefficient because of the overhead involved. Standard TCP is made up of three phases: setup, data transfer and release. First, TCP uses a three-way handshake to establish the connection. At least one additional packet is usually needed for transmission of the request, and requires three more packets to close the connection via a three-way handshake. So, for sending one data packet, TCP may need seven packets altogether. This kind of overhead is acceptable for long sessions in fixed networks, but is quite inefficient for short messages or sessions in wireless networks. This led to the development of transaction-oriented TCP (T/TCP).

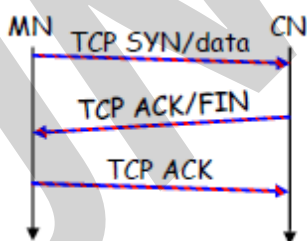
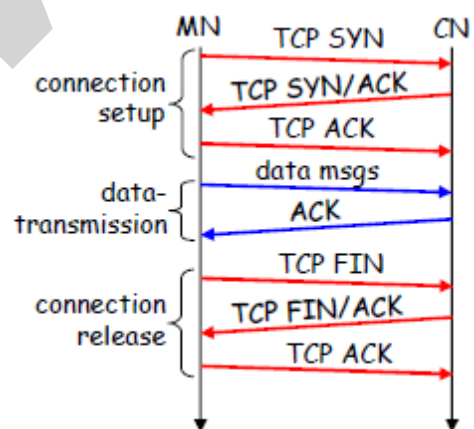

T/TCP can combine packets for connection establishment and connection release with user data packets. This can reduce the number of packets down to two instead of seven. The obvious **advantage** for certain applications is the reduction in the overhead which standard TCP has for connection setup and connection release. Disadvantage is that it requires changes in the software in mobile host



and all correspondent hosts. This solution does not hide mobility anymore. Also, T/TCP exhibits several security problems.

### **Classical Enhancements to TCP for mobility: A comparison**

Approach	Mechanism	Advantages	Disadvantages
Indirect TCP	splits TCP connection into two connections	isolation of wireless link, simple	loss of TCP semantics, higher latency at handover
Snooping TCP	"snoops" data and acknowledgements, local retransmission	transparent for end-to-end connection, MAC integration possible	problematic with encryption, bad isolation of wireless link
M-TCP	splits TCP connection, chokes sender via window size	Maintains end-to-end semantics, handles long term and frequent disconnections	Bad isolation of wireless link, processing overhead due to bandwidth management
Fast retransmit/ fast recovery	avoids slow-start after roaming	simple and efficient	mixed layers, not transparent
Transmission/ time-out freezing	freezes TCP state at disconnect, resumes after reconnection	independent of content or encryption, works for longer interrupts	changes in TCP required, MAC dependant
Selective retransmission	retransmit only lost data	very efficient	slightly more complex receiver software, more buffer needed
Transaction oriented TCP	combine connection setup/release and data transmission	Efficient for certain applications	changes in TCP required, not transparent

## Unit-5

### Database

A database is a collection of systematically stored records or information. Databases store data in a particular logical manner. A mobile device is not always connected to the server or network; neither does the device retrieve data from a server or a network for each computation. Rather, the device caches some specific data, which may be required for future computations, during the interval in which the device is connected to the server or network. Caching entails saving a copy of select data or a part of a database from a connected system with a large database. The cached data is hoarded in the mobile device database. Hoarding of the cached data in the database ensures that even when the device is not connected to the network, the data required from the database is available for computing.

### Database Hoarding

Database hoarding may be done at the application tier itself. The following figure shows a simple architecture in which a mobile device API directly retrieves the data from a database. It also shows another simple architecture in which a mobile device API directly retrieves the data from a database through a program, for ex: IBM DB2 Everyplace (DB2e).

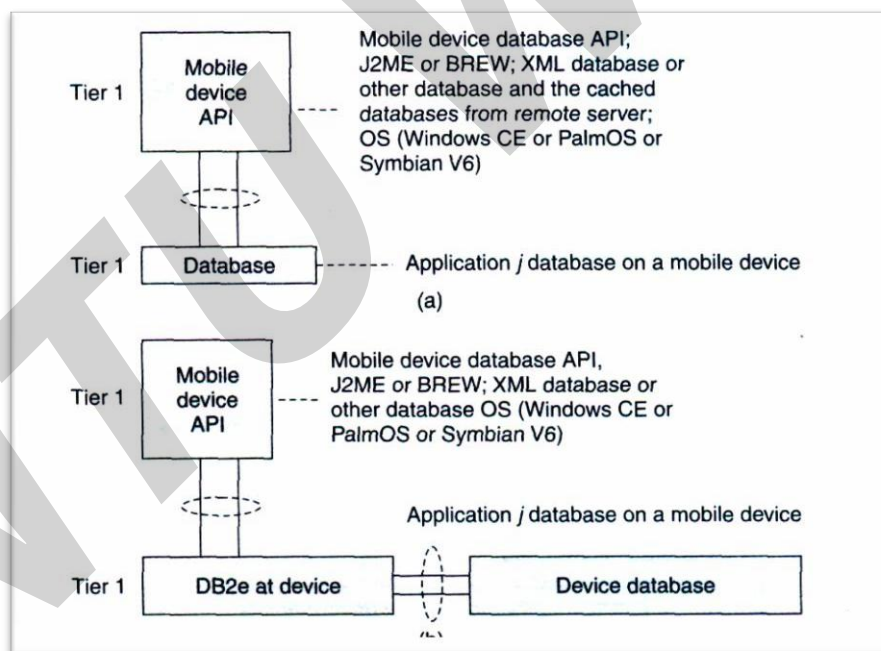

(a) API at mobile device sending queries and retrieving data from local database (Tier 1)  
 (b) API at mobile device retrieving data from database using DB2e (Tier 1)

Both the two architectures belong to the class of one-tier database architecture because the databases are specific to a mobile device, not meant to be distributed to multiple devices, not synchronized with the new updates, are stored at the device itself. Some examples are downloaded ringtones, music etc. **IBM DB2 Everyplace (DB2e)** is a relational database engine which has been designed to reside at the device. It supports J2ME and most mobile device operating systems. DB2e synchronizes with DB2 databases at the synchronization, application, or enterprise server

The database architecture shown below is for two-tier or multi-tier databases. Here, the databases reside at the remote servers and the copies of these databases are cached at the client tiers. This is known as client-server computing architecture.

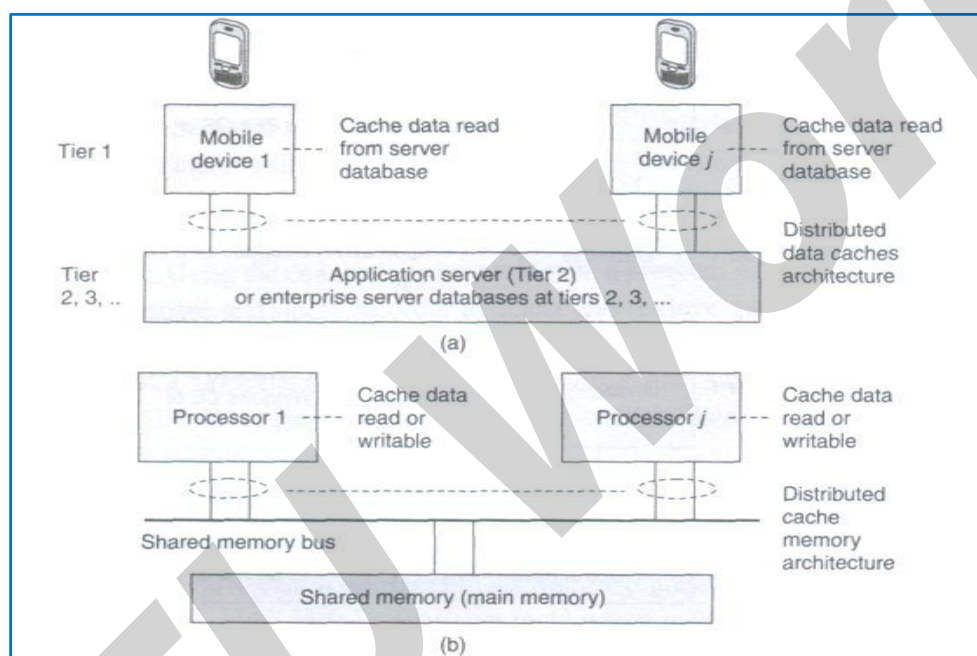

**(a) Distributed data caches in mobile devices**

**(b) Similar architecture for a distributed cache memory in multiprocessor systems**

A cache is a list or database of items or records stored at the device. Databases are hoarded at the application or enterprise tier, where the database server uses business logic and connectivity for retrieving the data and then transmitting it to the device. The server provides and updates local copies of the database at each mobile device connected to it. The computing API at the mobile device (first tier) uses the cached local copy. At first tier (tier 1), the API uses the cached data records using the computing architecture as explained above. From tier 2 or tier 3, the server retrieves and transmits the data records to tier 1 using business logic and synchronizes the local copies at the device. These local copies function as device caches.

The advantage of hoarding is that there is no access latency (delay in retrieving the queried record from the server over wireless mobile networks). The client device API has instantaneous data access to hoarded or cached data. After a device caches the data distributed by the server, the data is hoarded at the device. The disadvantage of hoarding is that the consistency of the cached data with the database at the server needs to be maintained.

## Data Caching

---

Hoarded copies of the databases at the servers are distributed or transmitted to the mobile devices from the enterprise servers or application databases. The copies cached at the devices are equivalent to the cache memories at the processors in a multiprocessor system with a shared main memory and copies of the main memory data stored at different locations.

**Cache Access Protocols:** A client device caches the pushed (disseminated) data records from a server. Caching of the pushed data leads to a reduced access interval as compared to the pull (on-demand) mode of data fetching. Caching of data records can be based on pushed 'hot records' (the most needed database records at the client device). Also, caching can be based on the ratio of two parameters—access probability (at the device) and pushing rates (from the server) for each record. This method is called cost-based data replacement or caching.

**Pre-fetching:** Pre-fetching is another alternative to caching of disseminated data. The process of pre-fetching entails requesting for and pulling records that may be required later. The client device can pre-fetch instead of caching from the pushed records keeping future needs in view. Pre-fetching reduces server load. Further, the cost of cache-misses can thus be reduced. The term 'cost of cache-misses' refers to the time taken in accessing a record at the server in case that record is not found in the device database when required by the device API.

### Caching Invalidation Mechanisms

A cached record at the client device may be invalidated. This may be due to expiry or modification of the record at the database server. Cache invalidation is a process by which a cached data item or record becomes invalid and thus unusable because of modification, expiry, or invalidation at another computing system or server. Cache invalidation mechanisms are used to synchronize the data at other processors whenever the cache-data is written (modified) by a processor in a multiprocessor system, cache invalidation mechanisms are also active in the case of mobile devices having distributed copies from the server.

A cache consists of several records. Each record is called a cache-line, copies of which can be stored at other devices or servers. The cache at the mobile devices or server databases at any

given time can be assigned one of four possible tags indicating its state—*modified* (after rewriting), *exclusive*, *shared*, and *invalidated* (after expiry or when new data becomes available) at any given instance. These four states are indicated by the letters M, E, S, and I, respectively (MESI). The states indicated by the various tags are as follows:

- The **E** tag indicates the *exclusive* state which means that the data record is for internal use and cannot be used by any other device or server.
- The **S** tag indicates the *shared* state which indicates that the data record can be used by others.
- The **M** tag indicates the *modified* state which means that the device cache
- The **I** tag indicates the *invalidated state* which means that the server database no longer has a copy of the record which was shared and used for computations earlier.

The following figure shows the four possible states of a data record  $i$  at any instant in the server database and its copy at the cache of the mobile device  $j$ .

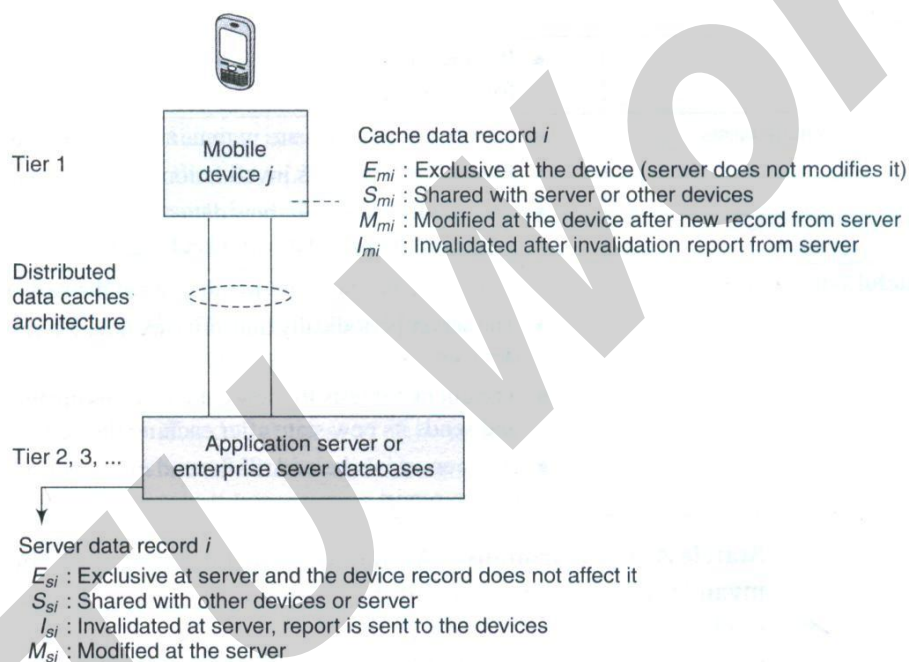

### Four possible states (*M, E, S, or I*) of a data record/at any instance at the server database and device $j$ cache

Another important factor for cache maintenance in a mobile environment is *cache consistency* (also called *cache coherence*). This requires a mechanism to ensure that a database record is identical at the server as well as at the device caches and that only the valid cache records are used for computations.

Cache invalidation mechanisms in mobile devices are triggered or initiated by the server. There are four possible invalidation mechanisms – Stateless asynchronous, stateless synchronous, stateful asynchronous and stateful synchronous.

Stateless Asynchronous: A stateless mechanism entails broadcasting of the invalidation of the cache to all the clients of the server. The server does not keep track of the records stored at the device caches. It just uniformly broadcasts invalidation reports to all clients irrespective of whether the device cache holds that particular record or not. The term 'asynchronous' indicates that the invalidation information for an item is sent as soon as its value changes. The server does not keep the information of the present state (whether  $E_{mi}$ ,  $M_{mi}$ ,  $S_{mi}$ , or  $I_{mi}$ ) of a data-record in cache for broadcasting later. The server advertises the invalidation information only. The client can either request for a modified copy of the record or cache the relevant record when data is pushed from the server. The server advertises as and when the corresponding data-record at the server is invalidated and modified (deleted or replaced).

The advantage of the asynchronous approach is that there are no frequent, unnecessary transfers of data reports, thus making the mechanism more bandwidth efficient. The disadvantages of this approach are—(a) every client device gets an invalidation report, whether that client requires that copy or not and (b) client devices presume that as long as there is no invalidation report, the copy is valid for use in computations. Therefore, even when there is link failure, the devices may be using the invalidated data and the server is unaware of state changes at the clients after it sends the invalidation report.

Stateless Synchronous This is also a stateless mode, i.e., the server has no information regarding the present state of data records at the device caches and broadcasts to all client devices. However, unlike the asynchronous mechanism, here the server advertises invalidation information at periodic intervals as well as whenever the corresponding data-record at server is invalidated or modified. This method ensures synchronization because even if the in-between period report is not detected by the device due to a link failure, the device expects the period-end report of invalidation and if that is not received at the end of the period, then the device sends a request for the same (deleted or replaced). In case the client device does not get the periodic report due to link failure, it requests the server to send the report.

The advantage of the synchronous approach is that the client devices receive periodic information regarding invalidity (and thus validity) of the data caches. The periodic invalidation reports lead to greater reliability of cached data as update requests for invalid data can be sent to the server by the device-client. This also helps the server and devices maintain cache consistency through periodical exchanges. The disadvantages of this mode of cache invalidation are—(a) unnecessary transfers of data invalidation reports take place, (b) every client device gets an advertised invalidation report periodically, irrespective of whether that client has a copy of the invalidated data or not, and (c) during the period between two invalidation reports, the client

devices assume that, as long as there is no invalidation report, the copy is valid for use in computations. Therefore, when there are link failures, the devices use data which has been invalidated in the in-between period and the server is unaware of state changes at the clients after it sends the invalidation report.

**Stateful Asynchronous** The stateful asynchronous mechanism is also referred to as the AS (asynchronous stateful) scheme. The term 'stateful' indicates that the cache invalidation reports are sent only to the affected client devices and not broadcasted to all. The server stores the information regarding the present state (a record  $I$  can have its state as  $E_{mi}$ ,  $M_{mi}$ ,  $S_{mi}$ , or  $I_{mi}$ ) of each data-record at the client device caches. This state information is stored in the home location cache (HLC) at the server. The HLC is maintained by an HA (home agent) software. This is similar to the HLR at the MSC in a mobile network. The client device informs the HA of the state of each record to enable storage of the same at the HLC. The server transmits the invalidation information as and when the records are invalidated and it transmits only to the device-clients which are affected by the invalidation of data. Based on the invalidation information, these device-clients then request the server for new or modified data to replace the invalidated data. After the data records transmitted by the server modify the client device cache, the device sends information about the new state to the server so that the record of the cache-states at the server is also modified.

The advantage of the stateful asynchronous approach is that the server keeps track of the state of cached data at the client device. This enables the server to synchronize with the state of records at the device cache and keep the HLC updated. The stateful asynchronous mode is also advantageous in that only the affected clients receive the invalidation reports and other devices are not flooded with irrelevant reports. The disadvantage of the AS scheme is that the client devices presume that, as long as there is no invalidation report, the copy is valid for use in computations. Therefore, when there is a link failure, then the devices use invalidated data.

**Stateful Synchronous:** The server keeps the information of the present state ( $E_{mi}$ ,  $M_{mi}$ ,  $S_{mi}$ , or  $I_{mi}$ ) of data-records at the client-caches. The server stores the cache record state at the home location cache (HLC) using the home agent (HA). The server transmits the invalidation information at periodic intervals to the clients and whenever the data-record relevant to the client is invalidated or modified (deleted or replaced) at the server. This method ensures synchronization because even if the in-between period report is not detected by the device due to a link failure, the device expects the period-end report of invalidation and if it is not received at the end of the period, then the device requests for the same.

The advantage of the stateful synchronous approach is that there are reports identifying invalidity (and thus, indirectly, of validity) of data caches at periodic intervals and that the server also periodically updates the client-cache states stored in the HLC. This enables to synchronize with the client device when invalid data gets modified and becomes valid. Moreover, since the invalidation report is sent periodically, if a device does not receive an invalidation report after

the specified period of time, it can request the server to send the report. Each client can thus be periodically updated of any modifications at the server. When the invalidation report is not received after the designated period and a link failure is found at the device, the device does not use the invalidated data. Instead it requests the server for an invalidation update. The disadvantage of the stateful synchronous approach is the high bandwidth requirement to enable periodic transmission of invalidation reports to each device and updating requests from each client device.

## **Data Cache Maintenance in Mobile Environments**

Assume that a device needs a data-record during an application. A request must be sent to the server for the data record (this mechanism is called pulling). The time taken for the application software to access a particular record is known as *access latency*. Caching and hoarding the record at the device reduces access latency to zero. Therefore, data cache maintenance is necessary in a mobile environment to overcome access latency.

*Data cache inconsistency* means that data records cached for applications are not invalidated at the device when modified at the server but not modified at the device. Data cache consistency can be maintained by the three methods given below:

- I. *Cache invalidation mechanism (server-initiated case)*: the server sends invalidation reports on invalidation of records (asynchronous) or at regular intervals (synchronous).
- II. *Polling mechanism (client-initiated case)*: Polling means checking from the server, the state of data record whether the record is in the valid, invalid, modified, or exclusive state. Each cached record copy is polled whenever required by the application software during computation. If the record is found to be modified or invalidated, then the device requests for the modified data and replaces the earlier cached record copy.
- III. *Time-to-live mechanism (client-initiated case)*: Each cached record is assigned a TTL (time-to-live). The TTL assignment is adaptive (adjustable) previous update intervals of that record. After the end of the TTL, the cached record copy is polled. If it is modified, then the device requests the server to replace the invalid cached record with the modified data. When TTL is set to 0, the TTL mechanism is equivalent to the polling mechanism.

## **Web Cache Maintenance in Mobile Environments**

The mobile devices or their servers can be connected to a web server (e.g., traffic information server or train information server). Web cache at the device stores the web server data and maintains it in a manner similar to the cache maintenance for server data described above. If an application running at the device needs a data record from the web which is not at the web cache, then there is access latency. Web cache maintenance is necessary in a mobile environment to overcome access latency in downloading from websites due to disconnections. Web cache consistency can be maintained by two methods. These are:



**Mobile Computing****Database Issues****Unit-5**

- I. Time-to-live (TTL) mechanism (client-initiated case): The method is identical to the one discussed for data cache maintenance.
- II. Power-aware computing mechanism (client-initiated case): Each web cache maintained at the device can also store the CRC (cyclic redundancy check) bits. Assume that there are  $N$  cached bits and  $n$  CRC bits.  $N$  is much greater than  $n$ . Similarly at the server,  $n$  CRC bits are stored. As long as there is consistency between the server and device records, the CRC bits at both are identical. Whenever any of the records cached at the server is modified, the corresponding CRC bits at the server are also modified. After the TTL expires or on-demand for the web cache records by the client API, the cached record CRC is polled and obtained from the website server. If the  $n$  CRC bits at server are found to be modified and the change is found to be much higher than a given threshold (i.e., a significant change), then the modified part of the website hypertext or database is retrieved by the client device for use by the API. However, if the change is minor, then the API uses the previous cache. Since  $N \gg n$ , the power dissipated in the web cache maintenance method (in which invalidation reports and all invalidated record bits are transmitted) is much greater than that in the present method (in which the device polls for the significant change in the CRC bits at server and the records are transmitted only when there is a significant change in the CRC bits).

**Client-Server Computing**

Client-server computing is a distributed computing architecture, in which there are two types of nodes, i.e., the clients and the servers. A server is defined as a computing system, which responds to requests from one or more clients. A client is defined as a computing system, which requests the server for a resource or for executing a task. The client can either access the data records at the server or it can cache these records at the client device. The data can be accessed either on client request or through broadcasts or distribution from the server.

The client and the server can be on the same computing system or on different computing systems. Client-server computing can have  $N$ -tier architecture ( $N = 1, 2, \dots$ ). When the client and the server are on the same computing system then the number of tiers,  $N = 1$ . When the client and the server are on different computing systems on the network, then  $N = 2$ . A command interchange protocol (e.g., HTTP) is used for obtaining the client requests at the server or the server responses at the client.

The following subsections describe client-server computing in 2, 3, or  $N$ -tier architectures. Each tier connects to the other with a connecting, synchronizing, data, or command interchange protocol.

## Two-tier Client-Server Architecture

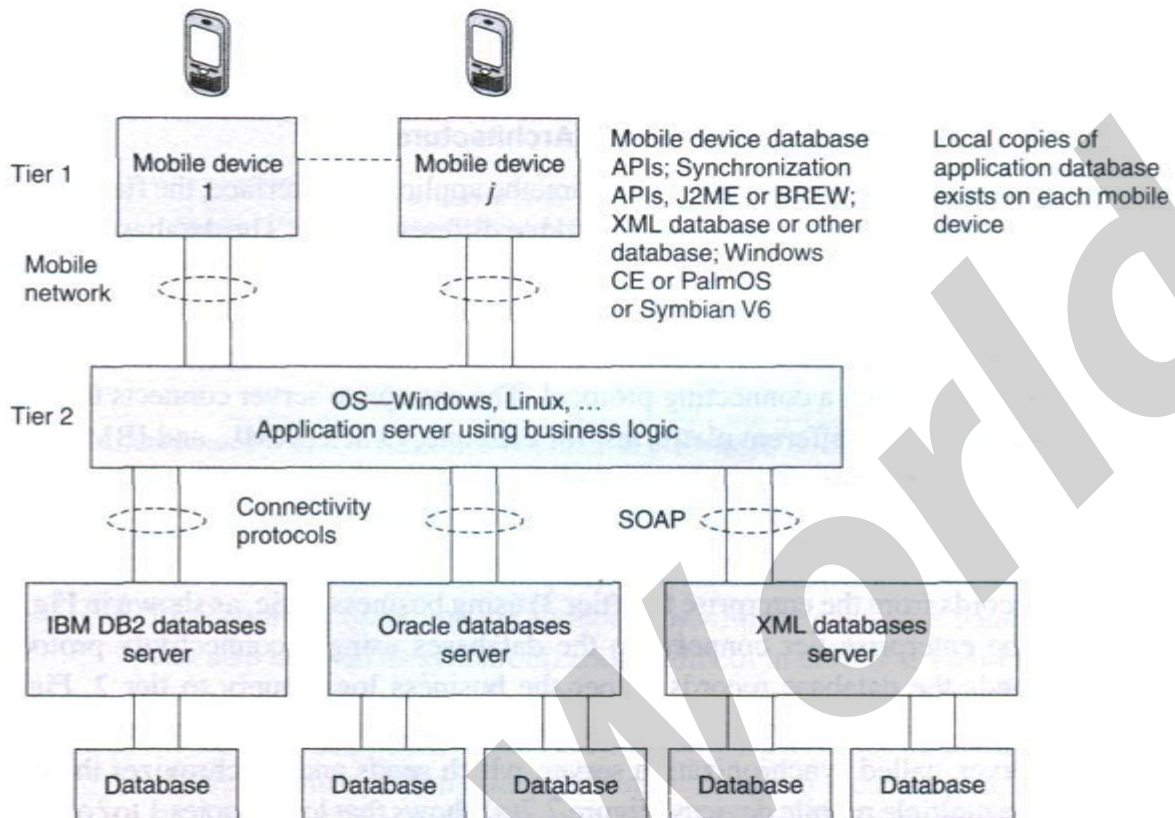

### **Multimedia file server in two-tier client-server computing architecture (local copies 1 to j of image and voice hoarding at the mobile devices)**

The following figure shows the application server at the second tier. The data records are retrieved using business logic and a synchronization server in the application server synchronizes with the local copies at the mobile devices. Synchronization means that when copies of records at the server-end are modified, the copies cached at the client devices should also be accordingly modified. The APIs are designed independent of hardware and software platforms as far as possible as different devices may have different platforms.

## Three-tier Client-Server Architecture

In a three-tier computing architecture, the application interface, the functional logic, and the database are maintained at three different layers. The database is associated with the enterprise server tier (tier 3) and only local copies of the database exist at mobile devices. The database connects to the enterprise server through a connecting protocol. The enterprise server connects the complete databases on different platforms, for example, Oracle, XML, and IBM DB2.

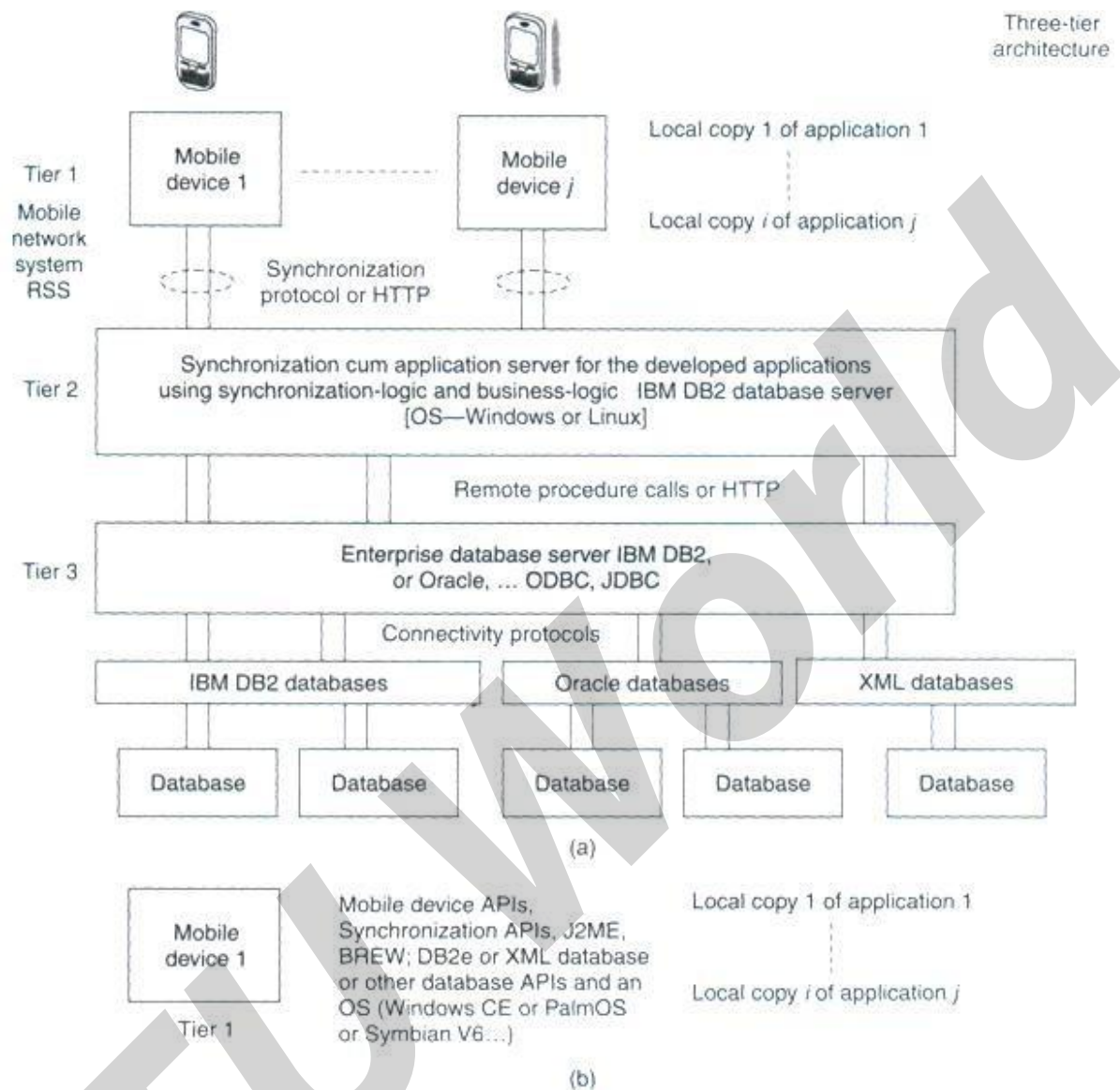

**(a) Local copies 1 to  $j$  of database hoarded at the mobile devices using an enterprise database connection synchronization server, which synchronizes the required local copies for application with the enterprise database server (b) Mobile device with J2ME or BREW platform, APIs an OS and database having local copies**

Data records at tier 3 are sent to tier 1 as shown in the figure through a synchronization-cum-application server at tier 2. The synchronization-cum-application server has synchronization and server programs, which retrieves data records from the enterprise tier (tier 3) using business logic. There is an in-between server, called synchronization server, which sends and synchronizes the copies at the multiple mobile devices. The figure shows that local copies 1 to  $j$  of databases are hoarded at the mobile devices for the applications 1 to  $j$ .

## **N-tier Client-Server Architecture**

When  $N$  is greater than 3, then the database is presented at the client through in-between layers. For example, the following figure shows a four-tier architecture in which a client device connects to a data-presentation server at tier 2.

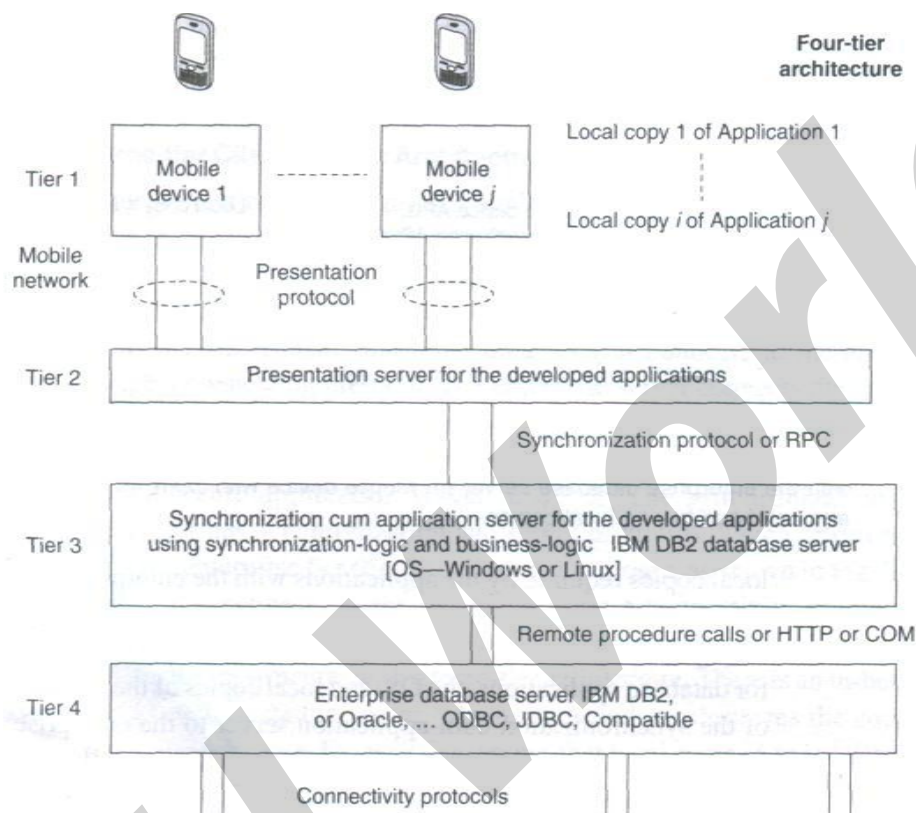

### **4-tier architecture in which a client device connects to a data-presentation server**

The presentation server then connects to the application server tier 3. The application server can connect to the database using the connectivity protocol and to the multimedia server using Java or XML API at tier 4. The total number of tiers can be counted by adding 2 to the number of in-between servers between the database and the client device. The presentation, application, and enterprise servers can establish connectivity using RPC, Java RMI, JNDI, or HOP. These servers may also use HTTP or HTTPS in case the server at a *tier j* connects to tier  $j+1$  using the Internet.

### **Client-Server Computing with Adaptation**

The data formats of data transmitted from the synchronization server and those required for the device database and device APIs are different in different cases, there are two adapters at a mobile device—an adapter for standard data format for synchronization at the mobile device and another adapter for the backend database copy, which is in a different data format for the API at the mobile device. An adapter is software to get data in one format or data governed by one protocol and convert it to another format or to data governed by another protocol.

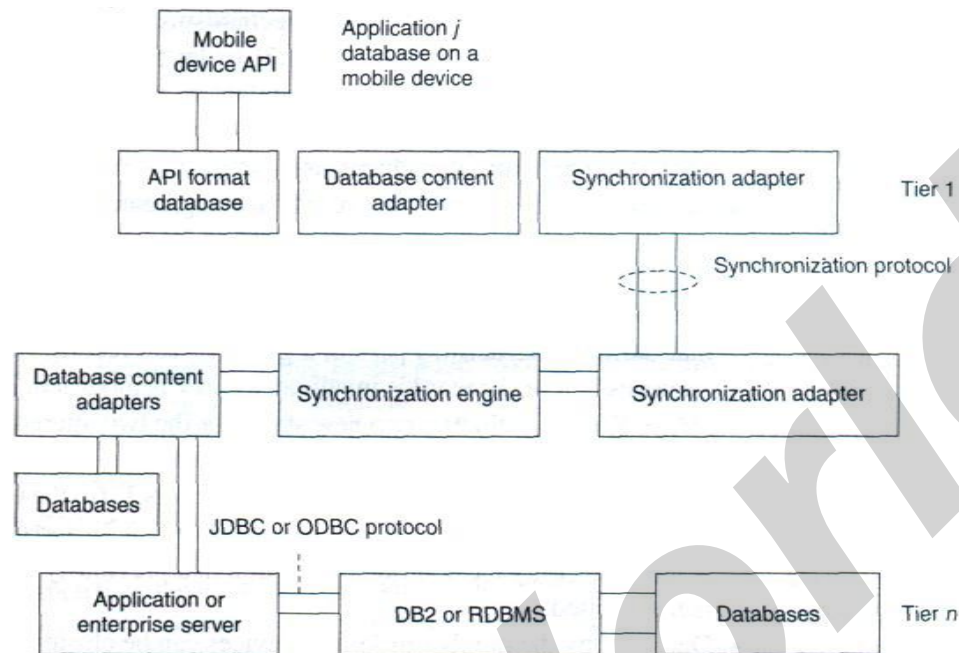

**Figure shows an API, database, and adapters at a mobile device and the adapters at the synchronization, application, or enterprise servers. Here the adapters are an addition used for interchange between standard data formats and data formats for the API.**

### **Context-aware Computing**

The context of a mobile device represents the circumstances, situations, applications, or physical environment under which the device is being used. For example, let us assume that a mobile phone is operating in a busy, congested area. If the device is *aware* of the surrounding noises, then during the conversation, it can raise the speaker volume by itself and when the user leaves that area, the device can again reduce the volume. Also, if there is intermittent loss of connectivity during the conversation, the device can introduce background noises by itself so that the user does not feel discomfort due to intermittent periods of silence. This is one example in which the computing system is aware of the surrounding physical context in which the conversation is taking place.

A context-aware computing system is one which has user, device, and application interfaces such that, using these, the system remains aware of the past and present surrounding situations, circumstances, or actions such as the present mobile network, surrounding devices or systems, changes in the state of the connecting network, physical parameters such as present time of the day, presently remaining memory and battery power, presently available nearest connectivity, past sequence of actions of the device user, past sequence of application or applications, and previously cached data records, and takes these into account during computations.

## Context

The term 'context' refers to the interrelated conditions in which a collection of elements, records, components, or entities exists or occurs. Each message, data record, element, or entity has a meaning. But when these are considered along with the conditions that relate them to each other and to the environment, then they have a wider meaning. Understanding of the context in which a device is meant to operate, results in better, more efficient computing strategies.

**Structural Context:** To explain what is meant by structural context let us consider a few examples of records with structural arrangement. The fields *name*, *address*, *experience*, and *achievements* of a person have an individual meaning. However, when put together to form a resume, these fields acquire a significance beyond their individual meanings. This significance comes from the fact that they are now arranged in a structure which indicates an interrelationship between them. The structure of the resume includes the records and their interrelationship and thus defines a context for these records. Whereby, the records have a new meaning in the context of the resume (which is a structure). Contexts such as the context of the resume of an individual are called structural contexts. The context in such cases comes from the structure or format in which the records in a database are organized.

Consider another example, this time that of a line in a telephone directory. It has a sequence of records including a name, an address, and a 10-digit number. Each record has an individual meaning. But a collection of these records shows an interrelationship and thus defines a context, i.e., a telephone directory.

**Implicit and Explicit Contexts** Context may be implicit or explicit. Implicit context provides for omissions by leaving out unimportant details, takes independent world-views, and performs alterations in order to cope with incompatible protocols, interfaces, or APIs by transparently changing the messages. Implicit context uses history to examine call history, to manage omissions, or to determine recipients and performs contextual message alterations. Consider the context '*Contacts*' which has a set of contacts. The name, e-mail ID, and telephone number are implicit in a *contact* in the context *Contacts*. When a computing device uses a contact to call a number using a name record, the system takes independent view and uses the telephone number implicitly and deploys CDMA or GSM protocols for connecting to the mobile network implicitly. Context CDMA is implicit in defining the records '*Contact*'. When a computing system uses a contact to send an e-mail using a name record, the use of the e-mail ID record is implicit to the system and the use of SMTP (simple mail transfer protocol) or other mail sending protocol is also implicit. Name gets automatically altered to e-mail ID when the context is sending of e-mail. The implicit context also copes with incompatible interfaces, for example, mail sending and receiving software handling data in different formats. Consider the context *document*. In *document* context, the contact or personal information is an extrinsic context. In context to processing of a

document, the existence of document author contact information is extrinsic. The *contacts* context is imported into the *document* context to establish interrelationship between *document* and *contact*.

### **Context-aware Computing**

Context-aware computing leads to application-aware computing. This is so because the APIs are part of the context (implicit or explicit contexts). For example, if context is a contact, the phone-talk application will adapt itself to use of the telephone number from the 'contact' and to the use of GSM or CDMA communication.

Use of context in computing helps in reducing possibility of errors. It helps in reducing the ambiguity in the action(s). It helps in deciding the expected system response on computations. For example, if *name* is input in personal biodata context, then the *address*, *experience*, and *achievements*, which correspond to that name, are also required for computations. This is because all four are related and needed in biodata context. When *name* is input in telephone directory context, then the *address* and phone number, which correspond to that name, are also required for computations. This is because all three are related in context to telephone directory. The *name* in two different contexts (personal biodata and telephone directory) during computations needs computations to perform different actions.

### **Context Types in Context-aware Computing**

The five types of contexts that are important in context-aware computing are-physical context, computing context, user context, temporal context, and structural context.

- **Physical Context:** The context can be that of the physical environment. The parameters for defining a physical context are service disconnection, light level, noise level, and signal strength. For example, if there is service disconnection during a conversation, the mobile device can sense the change in the physical conditions and it interleaves background noise so that the listener does not feel the effects of the disconnection. Also, the mobile device can sense the light levels, so during daytime the display brightness is increased and during night time or in poor light conditions, the device display brightness is reduced. The physical context changes and the device display is adjusted accordingly.
- **Computing Context:** The context in a context-aware computing environment may also be computing context. Computing context is defined by interrelationships and conditions of the network connectivity protocol in use (Bluetooth, ZigBee, GSM, GPRS, or CDMA), bandwidth, and available resources. Examples of resources are keypad, display unit, printer, and cradle. A cradle is the unit on which the mobile device lies in order to connect to a computer in the vicinity. Consider a mobile device lying on a cradle. It discovers the computing context and uses ActiveSync to synchronize and download from the computer. When a mobile device lies in the

vicinity of a computer with a Bluetooth interface, it discovers another computing context resource and uses wireless Bluetooth for connecting to the computer. When it functions independently and connects to a mobile network, it discovers another computing context and uses a GSM, CDMA, GPRS, or EDGE connection. The response of the system is as per the computing context, i.e., the network connectivity protocol.

- ***User Context:*** The user context is defined user location, user profiles, and persons near the user. Reza B 'Far defines user-interfaces context states as follows—'within the realm of user interfaces, we can define context as the sum of the relationships between the user interface components, the condition of the user, the primary intent of the system, and all of the other elements that allow users and computing systems to communicate.
- ***Temporal Context:*** Temporal context defines the interrelation between time and the occurrence of an event or action. A group of interface components have an intrinsic or extrinsic temporal context. For example, assume that at an instant the user presses the switch for *dial* in a mobile device. At the next instant the device seeks a *number* as an input. Then user will consider it in the context of dialling and input the number to be dialled. Now, assume that at another time the user presses the switch to *add* a contact in the mobile device. The device again prompts the user to enter a *number* as an input. The user will consider it in context of the number to be added in the *contacts and* stored in the device for future use. The device then seeks the name of the contact as the input. Response of the system in such cases is as per the temporal context. The context for the VUI (voice user interface) elements also defines a temporal context (depending upon the instances and sequences in which these occur).
- ***Structural Context:*** Structural context defines a sequence and structure formed by the elements or records. Graphic user interface (GUI) elements have structural context. Structural context may also be extrinsic for some other type of context. Interrelation among the GUI elements depends on structural positions on the display screen. When time is the context, then the hour and minute elements.

## **Transaction Models**

A transaction is the execution of interrelated instructions in a sequence for a specific operation on a database. Database transaction models must maintain data integrity and must enforce a set of rules called ACID rules. These rules are as follows:

- ❖ ***Atomicity:*** All operations of a transaction must be complete. In case, a transaction cannot be completed; it must be undone (rolled back). Operations in a transaction are assumed to be one indivisible unit (atomic unit).



- ❖ **Consistency:** A transaction must be such that it preserves the integrity constraints and follows the declared consistency rules for a given database. Consistency means the data is not in a contradictory state after the transaction.
- ❖ **Isolation:** If two transactions are carried out simultaneously, there should not be any interference between the two. Further, any intermediate results in a transaction should be invisible to any other transaction.
- ❖ **Durability:** After a transaction is completed, it must persist and cannot be aborted or discarded. For example, in a transaction entailing transfer of a balance from account A to account B, once the transfer is completed and finished there should be no roll back.

Consider a base class library included in Microsoft.NET. It has a set of computer software components called ADO.NET (ActiveX Data Objects in .NET). These can be used to access the data and data services including for access and modifying the data stored in relational database systems. The ADO.NET transaction model permits three transaction commands:

1. **BeginTransaction:** It is used to begin a transaction. Any operation after `BeginTransaction` is assumed to be a part of the transaction till the `CommitTransaction` command or the `RollbackTransaction` command. An example of a command is as follows:

```
connectionA.open();
transA = connectionA.BeginTransaction();
```

**Here connectionA and transA are two distinct objects.**

2. **Commit:** It is used to commit the transaction operations that were carried out after the `BeginTransaction` command and up to this command. An example of this is

```
transA.Commit();
```

**All statements between `BeginTransaction` and `commit` must execute automatically.**

3. **Rollback:** It is used to rollback the transaction in case an exception is generated after the `BeginTransaction` command is executed.

A DBMS may provide for auto-commit mode. *Auto-commit mode* means the transaction finished automatically even if an error occurs in between.

### Query Processing

Query processing means making a correct as well as efficient execution strategy by *query decomposition* and *query-optimization*. A relational-algebraic equation defines a set of operations needed during query processing. Either of the two equivalent relational-algebraic equations given below can be used.

$$\pi_{cName, cTelNum} (\sigma_{Contacts.firstChar = "R"} (\sigma_{Contacts.cTelNum = DialledNumbers.dTelNum} (Contacts) \times DialledNumbers))$$

This means first select a column `Contacts.cTelNum` in a row in `Contacts` in which `Contacts.cTelNum` column equals a column `DialledNumbers.dTelNum` by crosschecking and matching the records of a column in `Contacts` with all the rows of `DialledNumbers`. Then in the second step select the row in which `Contacts.firstChar = "R"` and the selected `cTelNum` exists. Then in the third step project `cName` and `cTelNum`.

$$\pi_{cName, cTelNum} (\sigma_{Contacts.firstChar = "R" \wedge Contacts.cTelNum = DialledNumbers.dTelNum} (Contacts \times DialledNumbers))$$

This means that in first series of step, crosscheck all rows of `Contacts` and `DialledNumbers` and select, after AND operation, the rows in which `Contacts.firstchar = "R"` and `Contacts.cTelNum = DialledNumbers.dTelNum`. Then in the next step project `cName` and `cTelNum` form the selected records.

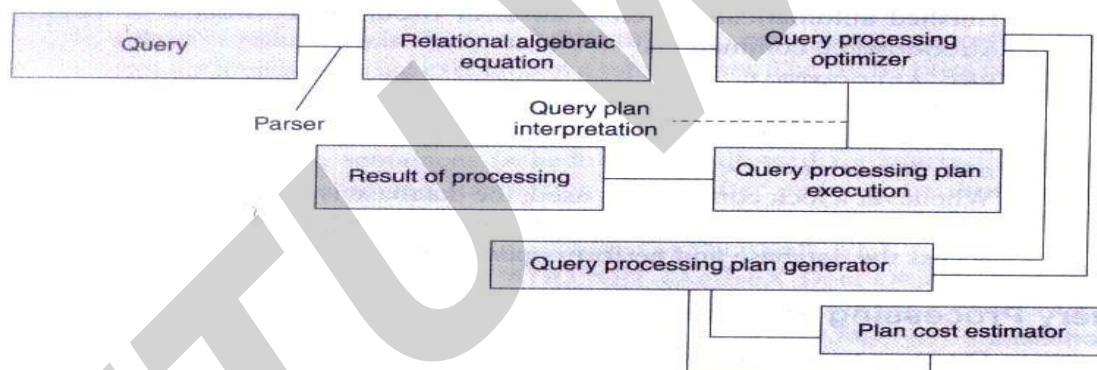

### Query processing architecture

$\Pi$  represents the projection operation,  $\sigma$  the *selection* operation, and  $\wedge$ , the AND operation. It is clear that the second set of operations in query processing is less efficient than the first. Query decomposition of the first set gives efficiency. Decomposition is done by (i) analysis, (ii) conjunctive and disjunctive normalization, and (iii) semantic analysis.

Efficient processing of queries needs optimization of steps for query processing. Optimization can be based on cost (number of micro-operations in processing) by evaluating the costs of sets of equivalent expressions. Optimization can also be based on a heuristic approach consisting of

the following steps: perform the selection steps and projection steps as early as possible and eliminate duplicate operations.

The query optimizer employs (a) query processing plan generator and (b) query processing cost estimator to provide an efficient plan for query processing.

### **Data Recovery Process**

Data is non-recoverable in case of media failure, intentional attack on the database and transactions logging data, or physical media destruction. However, data recovery is possible in other cases. Figure below shows recovery management architecture. It uses a recovery manager, which ensures atomicity and durability. Atomicity ensures that an uncommitted but started transaction aborts on failure and aborted transactions are logged in log file. Durability ensures that a committed transaction is not affected by failure and is recovered. Stable state databases at the start and at the end of transactions reside in secondary storage. Transaction commands are sent to the recovery manager, which sends fetch commands to the database manager. The database manager processes the queries during the transaction and uses a database buffer. The recovery manager also sends the flush commands to transfer the committed transactions and database buffer data to the secondary storage. The recovery manager detects the results of operations. It recovers lost operations from the secondary storage. Recovery is by detecting the data lost during the transaction.

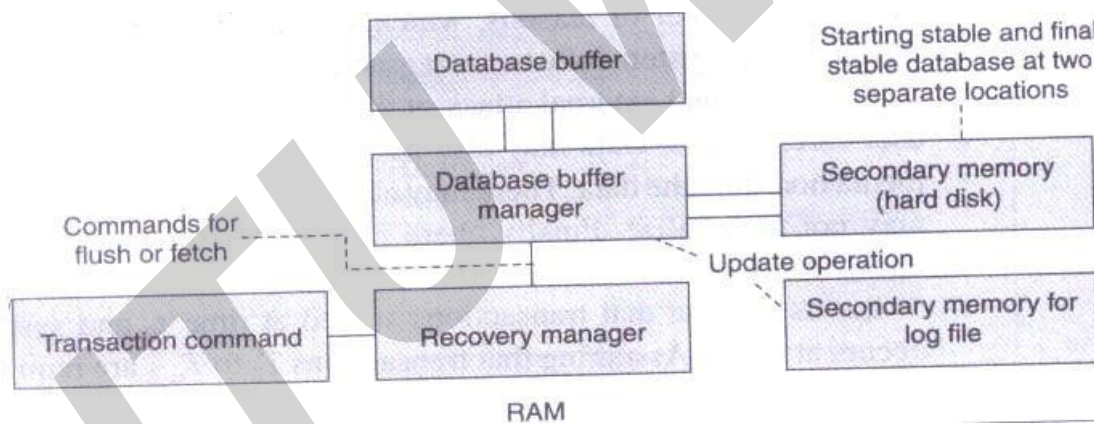

### **Recovery Management Architecture**

The recovery manager uses a log file, which logs actions in the following manner:

1. Each instruction for a transaction for update (insertion, deletion, replacement, and addition) must be logged.
2. Database read instructions are not logged
3. Log files are stored at a different storage medium.
4. Log entries are flushed out after the final stable state database is stored.

Each logged entry contains the following fields.

- transaction type (begin, commit, or rollback transaction)
- transaction ID
- operation-type
- object on which the operation is performed
- pre-operation and post-operation values of the object.

A procedure called the Aries algorithm is also used for recovering lost data. The basic steps of the algorithm are:

- I. Analyse from last checkpoint and identify all dirty records (written again after operation restarted) in the buffer.
- II. Redo all buffered operations logged in the update log to finish and make final page.
- III. Undo all write operations and restore pre-transaction values.

The recovery models used in data recovery processes are as follows:

- I. The *full recovery model* creates back up of the database and incremental backup of the changes. All transactions are logged from the last backup taken for the database.
- II. The *bulk logged recovery model* entails logging and taking backup of bulk data record operations but not the full logging and backup. Size of bulk logging is kept to the minimum required. This improves performance. We can recover the database to the point of failure by restoring the database with the bulk transaction log file backup. This is unlike the full recovery model in which all operations are logged.
- III. The *simple recovery model* prepares full backups but the incremental changes are not logged. We can recover the database to the most recent backup of the given database.

## Unit-6

### Data Dissemination

*Data Dissemination: Communications asymmetry, classification of new data delivery mechanisms, push-based mechanisms, pull-based mechanisms, hybrid mechanisms, selective tuning (indexing) techniques.*

Ongoing advances in communications including the proliferation of internet, development of mobile and wireless networks, high bandwidth availability to homes have led to development of a wide range of new-information centered applications. Many of these applications involve data dissemination, i.e. delivery of data from a set of producers to a larger set of consumers.

Data dissemination entails distributing and pushing data generated by a set of computing systems or broadcasting data from audio, video, and data services. The output data is sent to the mobile devices. A mobile device can select, tune and cache the required data items, which can be used for application programs.

Efficient utilization of wireless bandwidth and battery power are two of the most important problems facing software designed for mobile computing. Broadcast channels are attractive in tackling these two problems in wireless data dissemination. Data disseminated through broadcast channels can be simultaneously accessed by an arbitrary number of mobile users, thus increasing the efficiency of bandwidth usage.

### **Communications Asymmetry**

One key aspect of dissemination-based applications is their inherent communications asymmetry. That is, the communication capacity or data volume in the downstream direction (from servers-to-clients) is much greater than that in the upstream direction (from clients-to-servers). Content delivery is an asymmetric process regardless of whether it is performed over a symmetric channel such as the internet or over an asymmetric one, such as cable television (CATV) network. Techniques and system architectures that can efficiently support asymmetric applications will therefore be a requirement for future use.

Mobile communication between a mobile device and a static computer system is intrinsically asymmetric. A device is allocated a limited bandwidth. This is because a large number of devices access the network. Bandwidth in the downstream from the server to the device is much larger than the one in the upstream from the device to the server. This is because mobile devices have limited power resources and also due to the fact that faster data transmission rates for long intervals of time need greater power dissipation from the devices. In GSM networks data transmission rates go up to a maximum of 14.4 kbps for both uplink and downlink. The communication is symmetric and this symmetry can be maintained because GSM is only used for voice communication.

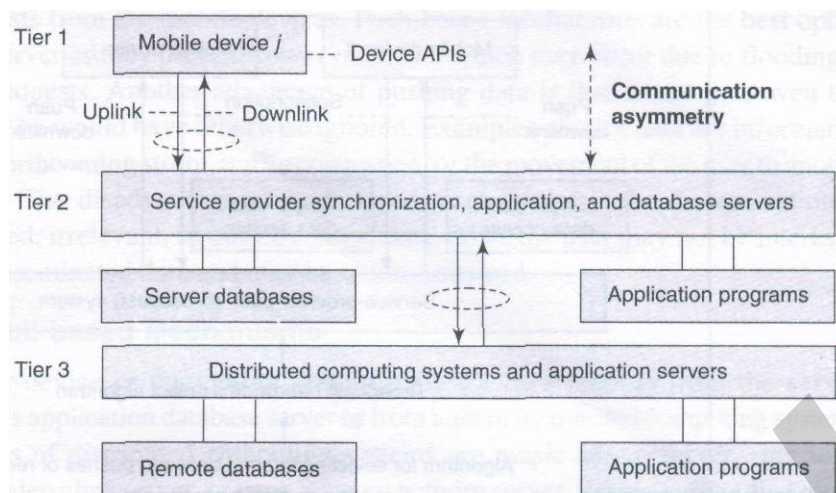

### Communication asymmetry in uplink and downlink and participation of device APIs and distributed computing systems when an application runs

The above figure shows communication asymmetry in uplink and downlink in a mobile network. The participation of device APIs and distributed computing systems in the running of an application is also shown.

## Classification of Data-Delivery Mechanisms

There are two fundamental information delivery methods for wireless data applications: Point-to-Point access and Broadcast. Compared with Point-to-Point access, broadcast is a more attractive method. A single broadcast of a data item can satisfy all the outstanding requests for that item simultaneously. As such, broadcast can scale up to an arbitrary number of users. There are three kinds of broadcast models, namely *push-based* broadcast, *On-demand* (or *pull-based*) broadcast, and *hybrid* broadcast. In push based broadcast, the server disseminates information using a periodic/aperiodic broadcast program (generally without any intervention of clients). In on demand broadcast, the server disseminates information based on the outstanding requests submitted by clients; In hybrid broadcast, push based broadcast and on demand data deliveries are combined to complement each other. In addition, mobile computers consume less battery power on monitoring broadcast channels to receive data than accessing data through point-to-point communications.

Data-delivery mechanisms can be classified into three categories, namely, push-based mechanisms (publish-subscribe mode), pull-based mechanisms (on-demand mode), and hybrid mechanisms (hybrid mode).

## **Push-based Mechanisms**

The server pushes data records from a set of distributed computing systems. Examples are advertisers or generators of traffic congestion, weather reports, stock quotes, and news reports. The following figure shows a push-based data-delivery mechanism in which a server or computing system pushes the data records from a set of distributed computing systems. The data records are pushed to mobile devices by broadcasting without any demand. The push mode is also known as **publish-subscribe** mode in which the data is pushed as per the subscription for a push service by a user. The subscribed query for a data record is taken as perpetual query till the user unsubscribe to that service. Data can also be pushed without user subscription.

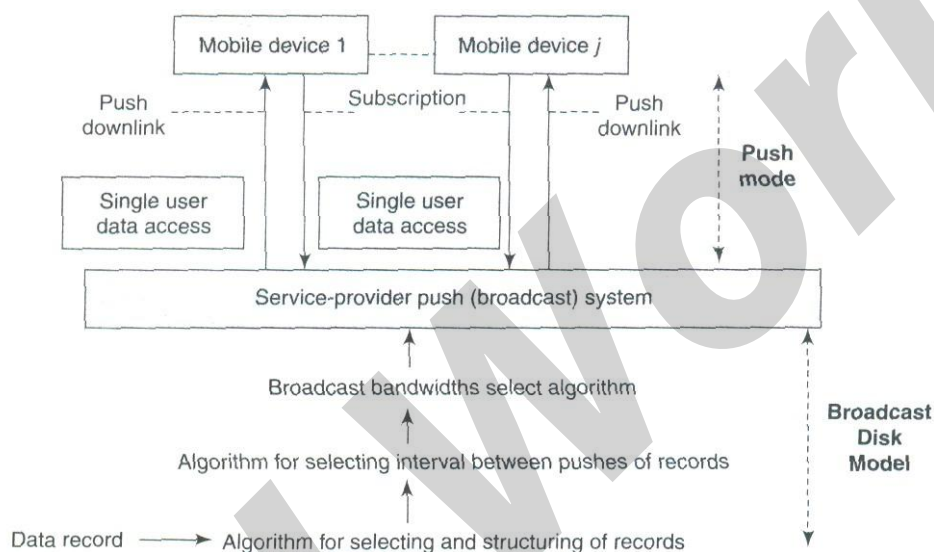

### **Push-based data-delivery mechanism**

Push-based mechanisms function in the following manner:

1. A structure of data records to be pushed is selected. An algorithm provides an adaptable multi-level mechanism that permits data items to be pushed uniformly or non-uniformly after structuring them according to their relative importance.
2. Data is pushed at selected time intervals using an adaptive algorithm. Pushing only once saves bandwidth. However, pushing at periodic intervals is important because it provides the devices that were disconnected at the time of previous push with a chance to cache the data when it is pushed again.
3. Bandwidths are adapted for downlink (for pushes) using an algorithm. Usually higher bandwidth is allocated to records having higher number of subscribers or to those with higher access probabilities.

4. A mechanism is also adopted to stop pushes when a device is handed over to another cell.

The application-distribution system of the service provider uses these algorithms and adopts bandwidths as per the number of subscribers for the published data records. On the device handoff, the subscription cancels or may be passed on to new service provider system.

Advantages of Push based mechanisms:

- Push-based mechanisms enable broadcast of data services to multiple devices.
- The server is not interrupted frequently by requests from mobile devices.
- These mechanisms also prevent server overload, which might be caused by flooding of device requests
- Also, the user even gets the data he would have otherwise ignored such as traffic congestion, forthcoming weather reports etc

Disadvantages:

- Push-based mechanisms disseminate of unsolicited, irrelevant, or out-of-context data, which may cause inconvenience to the user.

### **Pull based Mechanisms**

The user-device or computing system pulls the data records from the service provider's application database server or from a set of distributed computing systems. Examples are music album server, ring tones server, video clips server, or bank account activity server. Records are pulled by the mobile devices on demand followed by the selective response from the server. Selective response means that server transmits data packets as response selectively, for example, after client-authentication, verification, or subscription account check. The pull mode is also known as the on-demand mode. The following figure shows a pull-based data-delivery mechanism in which a device pulls (demands) from a server or computing system, the data records generated by a set of distributed computing systems.



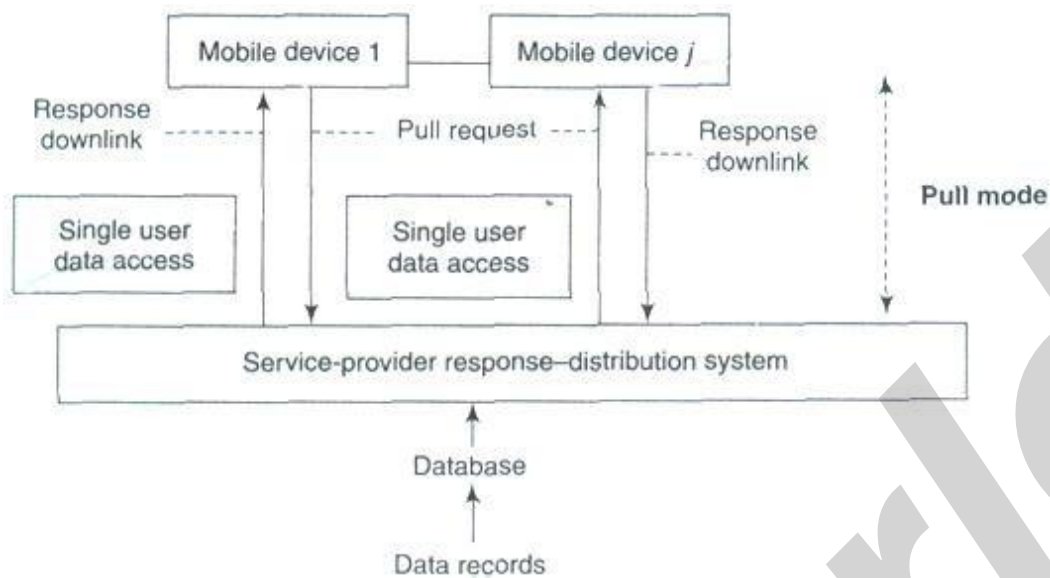

**Pull based Delivery Mechanism**

Pull-based mechanisms function in the following manner:

1. The bandwidth used for the uplink channel depends upon the number of pull requests.
2. A pull threshold is selected. This threshold limits the number of pull requests in a given period of time. This controls the number of server interruptions.
3. A mechanism is adopted to prevent the device from pulling from a cell, which has handed over the concerned device to another cell. On device handoff, the subscription is cancelled or passed on to the new service provider cell

In pull-based mechanisms the user-device receives data records sent by server on demand only.

Advantages of Pull based mechanisms:

- With pull-based mechanisms, no unsolicited or irrelevant data arrives at the device and the relevant data is disseminated only when the user asks for it.
- Pull-based mechanisms are the best option when the server has very little contention and is able to respond to many device requests within expected time intervals.

Disadvantages:

- The server faces frequent interruptions and queues of requests at the server may cause congestion in cases of sudden rise in demand for certain data record.
- In on-demand mode, another disadvantage is the energy and bandwidth required for sending the requests for hot items and temporal records

## Hybrid Mechanisms

A hybrid data-delivery mechanism integrates pushes and pulls. The hybrid mechanism is also known as interleaved-push-and-pull (IPP) mechanism. The devices use the back channel to send pull requests for records, which are not regularly pushed by the front channel. The front channel uses algorithms modeled as broadcast disks and sends the generated interleaved responses to the pull requests. The user device or computing system pulls as well receives the pushes of the data records from the service provider's application server or database server or from a set of distributed computing systems. Best example would be a system for advertising and selling music albums. The advertisements are pushed and the mobile devices pull for buying the album.

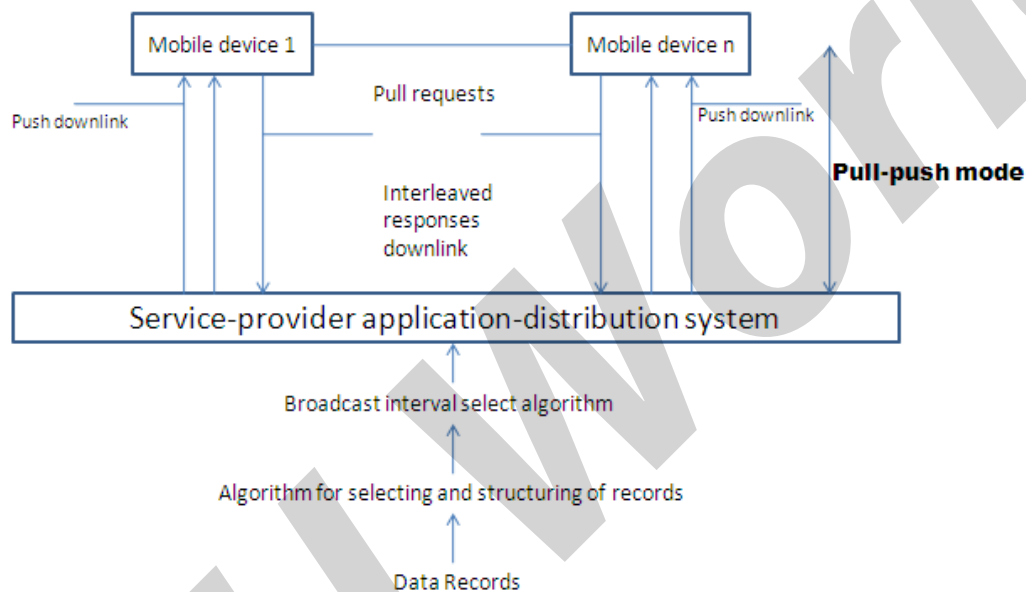

### **Hybrid interleaved push-pull-based data-delivery mechanism**

The above figure shows a hybrid interleaved, push-pull-based data-delivery mechanism in which a device pulls (demands) from a server and the server interleaves the responses along with the pushes of the data records generated by a set of distributed computing systems. Hybrid mechanisms function in the following manner:

1. There are two channels, one for pushes by front channel and the other for pulls by back channel.
2. Bandwidth is shared and adapted between the two channels depending upon the number of active devices receiving data from the server and the number of devices requesting data pulls from the server.
3. An algorithm can adaptively chop the slowest level of the scheduled pushes successively. The data records at lower level where the records are assigned lower priorities can have long push intervals in a broadcasting model.

### Advantages of Hybrid mechanisms:

- The number of server interruptions and queued requests are significantly reduced.

### Disadvantages:

- IPP does not eliminate the typical server problems of too many interruptions and queued requests.
- Another disadvantage is that adaptive chopping of the slowest level of scheduled pushes.

## Selective Tuning and Indexing Techniques

The purpose of pushing and adapting to a broadcast model is to push records of greater interest with greater frequency in order to reduce access time or average access latency. A mobile device does not have sufficient energy to continuously cache the broadcast records and hoard them in its memory. A device has to dissipate more power if it gets each pushed item and caches it. Therefore, it should be activated for listening and caching only when it is going to receive the selected data records or buckets of interest. During remaining time intervals, that is, when the broadcast data buckets or records are not of its interest, it switches to idle or power down mode.

Selective tuning is a process by which client device selects only the required pushed buckets or records, tunes to them, and caches them. Tuning means getting ready for caching at those instants and intervals when a selected record of interest broadcasts. Broadcast data has a structure and overhead. Data broadcast from server, which is organized into buckets, is interleaved. The server prefixes a directory, hash parameter (from which the device finds the key), or index to the buckets. These prefixes form the basis of different methods of selective tuning. Access time ( $t_{\text{access}}$ ) is the time interval between pull request from device and reception of response from broadcasting or data pushing or responding server. Two important factors affect  $t_{\text{access}}$  – (i) number and size of the records to be broadcast and (ii) directory- or cache-miss factor (if there is a miss then the response from the server can be received only in subsequent broadcast cycle or subsequent repeat broadcast in the cycle).

### **Directory Method**

One of the methods for selective tuning involves broadcasting a directory as overhead at the beginning of each broadcast cycle. If the interval between the start of the broadcast cycles is  $T$ , then directory is broadcast at each successive intervals of  $T$ . A directory can be provided which

specifies when a specific record or data item appears in data being broadcasted. For example, a directory (at header of the cycle) consists of directory start sign, 10, 20, 52, directory end sign. It means that after the directory end sign, the 10th, 20th and 52nd buckets contain the data items in response to the device request. The device selectively tunes to these buckets from the broadcast data.

A device has to wait for directory consisting of start sign, pointers for locating buckets or records, and end sign. Then it has to wait for the required bucket or record before it can get tuned to it and, start caching it. Tuning time  $t_{\text{tune}}$  is the time taken by the device for selection of records. This includes the time lapse before the device starts receiving data from the server. In other words, it is the sum of three periods—time spent in listening to the directory signs and pointers for the record in order to select a bucket or record required by the device, waiting for the buckets of interest while actively listening (getting the incoming record wirelessly), and caching the broadcast data record or bucket.

The device selectively tunes to the broadcast data to download the records of interest. When a directory is broadcast along with the data records, it minimizes  $t_{\text{tune}}$  and  $t_{\text{access}}$ . The device saves energy by remaining active just for the periods of caching the directory and the data buckets. For rest of the period (between directory end sign and start of the required bucket), it remains idle or performs application tasks. Without the use of directory for tuning,  $t_{\text{tune}} = t_{\text{access}}$  and the device is not idle during any time interval.

### **Hash-Based Method**

Hash is a result of operations on a pair of key and record. Advantage of broadcasting a hash is that it contains a fewer bits compared to key and record separately. The operations are done by a hashing function. From the server end the hash is broadcasted and from the device end a key is extracted by computations from the data in the record by operating the data with a function called hash function (algorithm). This key is called hash key.

Hash-based method entails that the hash for the hashing parameter (hash key) is broadcasted. Each device receives it and tunes to the record as per the extracted key. In this method, the records that are of interest to a device or those required by it are cached from the broadcast cycle by first extracting and identifying the hash key which provides the location of the record. This helps in tuning of the device. Hash-based method can be described as follows:

1. A separate directory is not broadcast as overhead with each broadcast cycle.
2. Each broadcast cycle has hash bits for the hash function  $H$ , a shift function  $S$ , and the data that it holds. The function  $S$  specifies the location of the

record or remaining part of the record relative to the location of hash and, thus, the time interval for wait before the record can be tuned and cached.

3. Assume that a broadcast cycle pushes the hashing parameters  $\mathbf{H}(R_i)$  [H and S] and record  $R_i$ . The functions H and S help in tuning to the  $\mathbf{H}(R_i)$  and hence to  $R_i$  as follows—H gives a key which in turn gives the location of  $\mathbf{H}(R_i)$  in the broadcast data. In case H generates a key that does not provide the location of  $\mathbf{H}(R_i)$  by itself, then the device computes the location from S after the location of  $\mathbf{H}(R_i)$ . That location has the sequential records  $R_i$  and the devices tunes to the records from these locations.
4. In case the device misses the record in first cycle, it tunes and caches that in next or some other cycle.

### **Index-Based Method**

Indexing is another method for selective tuning. Indexes temporarily map the location of the buckets. At each location, besides the bits for the bucket in record of interest data, an offset value may also be specified there. While an index maps to the absolute location from the beginning of a broadcast cycle, an offset index is a number which maps to the relative location after the end of present bucket of interest. Offset means a value to be used by the device along with the present location and calculate the wait period for tuning to the next bucket. All buckets have an offset to the beginning of the next indexed bucket or item.

Indexing is a technique in which each data bucket, record, or record block of interest is assigned an index at the previous data bucket, record, or record block of interest to enable the device to tune and cache the bucket after the wait as per the offset value. The server transmits this index at the beginning of a broadcast cycle as well as with each bucket corresponding to data of interest to the device. A disadvantage of using index is that it extends the broadcast cycle and hence increases  $t_{\text{access}}$ .

The index I has several offsets and the bucket type and flag information. A typical index may consist of the following:

1.  $I_{\text{offset}}(1)$  which defines the offset to first bucket of nearest index.
2. Additional information about  $T_b$ , which is the time required for caching the bucket bits in full after the device tunes to and starts caching the bucket. This enables transmission of buckets of variable lengths.
3.  $I_{\text{offset}}(\text{next})$  which is the index offset of next bucket record of interest.

4.  $I_{\text{offset}}(\text{end})$  which is the index offset for the end of broadcast cycle and the start of next cycle. This enables the device to look for next index  $I$  after the time interval as per  $I_{\text{offset}}(\text{end})$ . This also permits a broadcast cycle to consist of variable number of buckets.
5.  $I_{\text{type}}$ , which provides the specification of the type of contents of next bucket to be tuned, that is, whether it has an index value or data.
6. A flag called dirty flag which contains the information whether the indexed buckets defined by  $I_{\text{offset}}(1)$  and  $I_{\text{offset}}(\text{next})$  are dirty or not. An indexed bucket being dirty means that it has been rewritten at the server with new values. Therefore, the device should invalidate the previous caches of these buckets and update them by tuning to and caching them.

The advantage of having an index is that a device just reads it and selectively tunes to the data buckets or records of interest instead of reading all the data records and then discarding those which are not required by it. During the time intervals in which data which is not of interest is being broadcast, the device remains in idle or power down mode.

Transmission of an index  $I$  only once with every broadcast cycle increases access latency of a record as follows: This is so because if an index is lost during a push due to transmission loss, then the device must wait for the next push of the same index-record pair. The data tuning time now increases by an interval equal to the time required for one broadcast cycle. An index assignment strategy  $(I, m)$  is now described.  $(I, m)$  indexing means an index  $I$  is transmitted  $m$  times during each push of a record. An algorithm is used to adapt a value of  $m$  such that it minimizes access (caching) latency in a given wireless environment which may involve frequent or less frequent loss of index or data. Index format is adapted to  $(I, m)$  with a suitable value of  $m$  chosen as per the wireless environment. This decreases the probability of missing  $I$  and hence the caching of the record of interest

Indexing reduces the time taken for tuning by the client devices and thus conserves their power resources. Indexing increases access latency because the number of items pushed is more (equals  $m$  times index plus  $n$  records).

### **Distributed Index Based Method**

Distributed index-based method is an improvement on the  $(I, m)$  method. In this method, there is no need to repeat the complete index again and again. Instead of replicating the whole index  $m$  times, each index segment in a bucket describes only the offset  $I'$  of data items which immediately follow. Each index  $I$  is partitioned into two parts— $I'$  and  $I''$ .  $I''$  consists of

unrepeated  $k$  levels (sub-indexes), which do not repeat and  $l'$  consists of top  $l$  repeated levels (sub-indexes).

Assume that a device misses  $l$  (includes  $l'$  and  $l'$  once) transmitted at the beginning of the broadcast cycle. As  $l'$  is repeated  $m - l$  times after this, it tunes to the pushes by using  $l'$ , The access latency is reduced as  $l'$  has lesser levels.

### **Flexible Indexing Method**

Assume that a broadcast cycle has number of data segments with each of the segments having a variable set of records. For example, let  $n$  records,  $R_0$  to  $R_{n-1}$ , be present in four data segments,  $R_0$  to  $R_{i-1}$ ,  $R_i$  to  $R_{j-1}$ ,  $R_j$  to  $R_{j-1}$  and  $R_k$  to  $R_{n-1}$ . Some possible index parameters are (i)  $I_{seg}$ , having just 2 bits for the offset, to specify the location of a segment in a broadcast cycle, (ii)  $I_{rec}$ , having just 6 bits for the offset, to specify the location of a record of interest within a segment of the broadcast cycle, (iii)  $I_b$ , having just 4 bits for the offset, to specify the location of a bucket of interest within a record present in one of the segments of the broadcast cycle. Flexible indexing method provides dual use of the parameters (e.g., use of  $I_{seg}$  or  $I_{rec}$  in an index segment to tune to the record or buckets of interest) or multi-parameter indexing (e.g., use of  $I_{seg}$ ,  $I_{rec}$ , or  $I_b$  in an index segment to tune to the bucket of interest).

Assume that broadcast cycle has  $m$  sets of records (called segments). A set of binary bits defines the index parameter  $I_{seg}$ . A local index is then assigned to the specific record (or bucket). Only local index ( $I_{rec}$  or  $I_b$ ) is used in ( $I_{loc}$ ,  $m$ ) based data tuning which corresponds to the case of flexible indexing method being discussed. The number of bits in a local index is much smaller than that required when each record is assigned an index. Therefore, the flexible indexing method proves to be beneficial.

### **Alternative Methods**

**Temporal Addressing** Temporal addressing is a technique used for pushing in which instead of repeating  $l$  several times, a temporal value is repeated before a data record is transmitted. When temporal information contained in this value is used instead of address, there can be effective synchronization of tuning and caching of the record of interest in case of non-uniform time intervals between the successive bits. The device remains idle and starts tuning by synchronizing as per the temporal (time)-information for the pushed record. Temporal information gives the time at which cache is scheduled. Assume that temporal address is 25675 and each address corresponds to wait of 1 ms, the device waits and starts synchronizing the record after 25675 ms.

**Broadcast Addressing:** Broadcast addressing uses a broadcast address similar to IP or multicast address. Each device or group of devices can be assigned an address. The devices cache the records which have this address as the broadcasting address in a broadcast cycle. This address can be used along with the pushed record. A device uses broadcast address in place of the index I to select the data records or sets. Only the addressed device(s) caches the pushed record and other devices do not select and tune to the record. In place of repeating I several times, the broadcast address can be repeated before a data record is transmitted. The advantage of using this type of addressing is that the server addresses to specific device or specific group of devices.

**Use of Headers:** A server can broadcast a data in multiple versions or ways. An index or address only specifies where the data is located for the purpose of tuning. It does not specify the details of data at the buckets. An alternative is to place a header or a header with an extension with a data object before broadcasting. Header is used along with the pushed record. The device uses header part in place of the index / and in case device finds from the header that the record is of interest, it selects the object and caches it. The header can be useful, for example it can give information about the type, version, and content modification data or application for which it is targeted.



## Notes for Indexing Techniques (Prepared by Kancherla Yasesvi, 08071A0522)

### (1, m) Index

The (1, m) indexing scheme is an index allocation method where a complete index is broadcast m times during a broadcast. All buckets have an offset to the beginning of the next index segment. The first bucket of each index segment has a tuple containing two fields. The first field contains the key value of the object that was broadcast last and the second field is an offset pointing to the beginning of the next broadcast. This tuple guides clients who missed the required object in the current broadcast so that they can tune to the next broadcast.

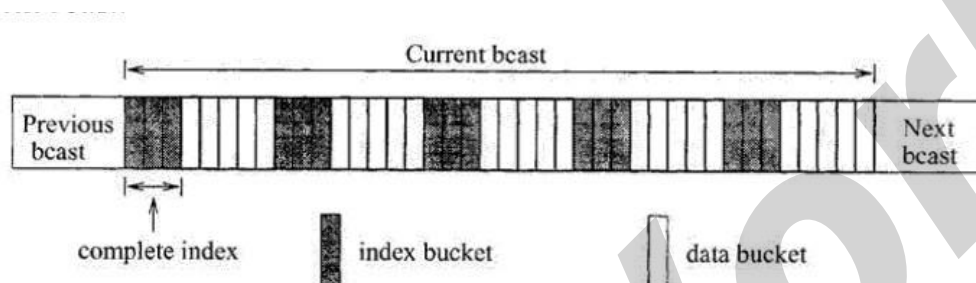

Figure 4.3. Bcast organization in the (1, m) indexing method.

**The client's access protocol for retrieving objects with key value k is as follows:**

1. Tune into the current bucket on the broadcast channel. Get the offset to the next index segment.
2. Go to the doze mode and tune in at the broadcast of the next index segment.
3. Examine the tuple in the first bucket of the index segment. If the target object has been missed, obtain the offset to the beginning of the next bcast and goto 2; otherwise goto 4.
4. Traverse the index and determine the offset to the target data bucket. This may be accomplished by successive probes, by following the pointers in the multi-level index. The client may doze off between two probes.
5. Tune in when the desired bucket is broadcast, and download it (and subsequent ones as long as their key is k).

**Advantage:**

1. This scheme has good tuning time.

**Disadvantage:**

1. The index is entirely replicated m times; this increases the length of the broadcast cycle and hence the average access time.

The optimal m value that gives minimal average access time is  $(\text{data file size}/\text{index size})^{1/2}$ .

There is actually no need to replicate the complete index between successive data blocks. It is sufficient to make available only the portion of index related to the data buckets which follow it. This is the approach adopted in all the subsequent indexing schemes.

### **Tree-based Index/Distributed indexing scheme**

In this scheme a data file is associated with a  $B^+$ -tree index structure. Since the broadcast medium is a sequential medium, the data file and index must be flattened so that the data and index are broadcast following a preorder traversal of the tree. The index comprises two portions: the first  $k$  levels of the index will be partially replicated in the broadcast, and the remaining levels will not be replicated. The index nodes at the  $(k+1)^{\text{th}}$  level are called the non-replicated roots.

Essentially, each index subtree whose root is a non-replicated root will appear once in the whole bcst just in front of the set of data segments it indexes. On the other hand, the nodes at the replicated levels are replicated at the beginning of the first broadcast of each of its children nodes.

To facilitate selective tuning, each node contains meta-data that help in the traversal of the trees. All non-replicated buckets contain pointers that will direct the search to the next copy of its replicated ancestors. On the other hand, all replicated index buckets contain two tuples that can direct the search to continue in the appropriate segments. The first tuple is a pair  $(x, ptr_{\text{begin}})$  that indicates that key values less than  $x$  have been missed and so search must continue from the beginning of the next bcst (which is  $ptr_{\text{begin}}$  buckets away). The second pair  $(y, ptr)$  indicates that key values greater than or equal to  $y$  can be found  $ptr$  offset away. Clearly, if the desired object has key value between  $x$  and  $y$ , the search can continue as in conventional search operation.

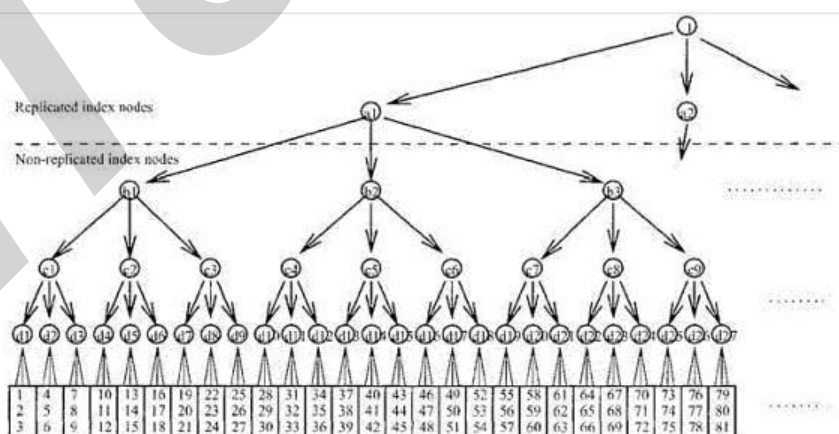

Figure 4.4. A partial data file and its index tree.

### The client's access protocol for retrieving objects with key value $k$ is as follows:

1. Tune to the current bucket of the bcast. Get the offset to the next index bucket, and doze off.
2. Tune to the beginning of the designated bucket and examine the meta-data.
  - If the desired object has been missed, doze off till the beginning of the next bcast. Goto 2.
  - If the desired object is not within the data segment covered by the index bucket, doze off to the next higher level index bucket. Goto 3.
  - If the desired object is within the data segment covered by the index bucket, goto 3.

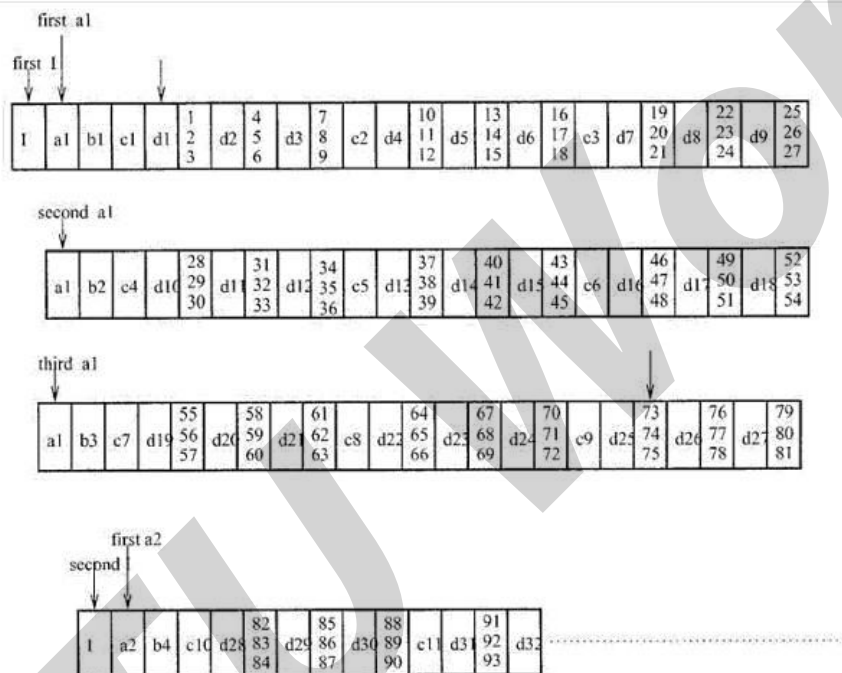

Figure 4.5. The data broadcast for the distributed indexing scheme with partial path replication.

3. Probe the designated index bucket and follow a sequence of pointers to determine when the data bucket containing the target object will be broadcast. The client may doze off in between two probes.
4. Tune in again when the bucket containing objects with key  $k$  is broadcast, and download the bucket (and all subsequent buckets as long as they contain objects with key  $k$ ).

### Advantage:

1. Compared to  $(1, m)$  index scheme this scheme has lower access time and its tuning time is also comparable to that of  $(1, m)$  index scheme.

## Flexible Indexing Scheme

This scheme splits a sorted list of objects into equal-sized segments, and provides indexes to navigate through the segments. At the beginning of each segment, there is a control index which comprises of two components: a global index and a local index. The global index is used to determine the segment which object may be found, while the local index provides the offset to the portion within the segment where the object may be found.

Suppose the file is organized into  $p$  segments. Then the global index at a segment, says, has  $\lceil \log_2 i \rceil$  (key, ptr) pairs, where  $i$  is the number of segments in front of and including segment  $s$ , key is an object key, and ptr is an offset. For the first entry, key is the key value of the first data item in segment  $s$  and ptr is the offset to the beginning of the next version. Bold examining this pair, the client will know if it has missed the data and if so wait till the next broadcast. For the  $j^{\text{th}}$  entry ( $j > 1$ ), key is the key value of the first data item in the  $(\lceil \log_2 i / 2^{j-1} \rceil + 1)^{\text{th}}$  segment following segment  $s$  and ptr is the offset to the first data bucket of that segment.

The local index consists of  $m$  (key, ptr) pairs that essentially partition each segment further into  $m+1$  sections. For the first entry, key is the key value of the first data item of section  $m+1$  and ptr is the offset to that section. For the  $j^{\text{th}}$  pair, key is the key value of the first data item of section  $(m+1-j)$  and ptr is the offset to the first bucket of that section.

Hence, it is clear that the number of segments and the number of sections per segment can affect the performance of the scheme. Increasing the number of segments or sections will increase the length of the broadcast cycle and reduce the tuning time, and vice versa. Thus, the scheme is flexible in the sense it can be tuned to fit an application's needs.

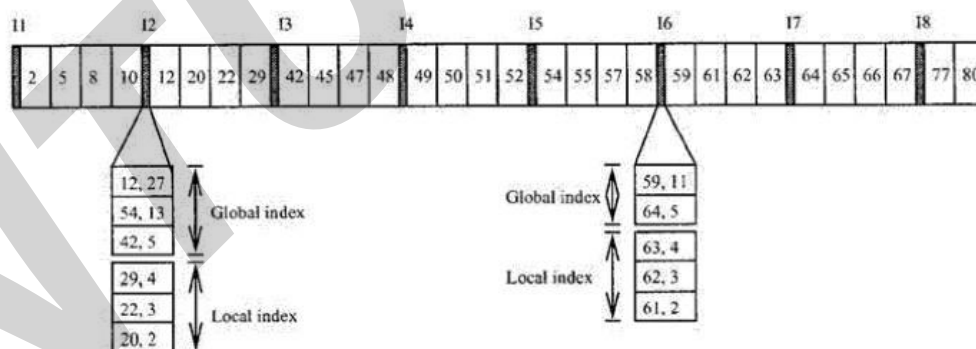

Figure 4.8. Flexible index scheme.

**The client's access protocol for retrieving objects with key value  $k$  is as follows:**

1. Tune into the channel for a bucket, obtain the offset to the next index segment. Doze off until the next index segment is broadcast.
2. Examine the global index entries. If the target object belongs to another segment, get the offset; doze off for appropriate amount of time and goto 2.
3. Examine the local index entries. Obtain the offset to the section where the target data is stored. Switch to doze mode for appropriate amount of time.
4. Examine objects in the data bucket for the desired object, and download the object.

## Unit-7

### Mobile Ad Hoc Networks (MANETs)

**Mobile Ad hoc NETWORKS (MANETs)** are wireless networks which are characterized by dynamic topologies and no fixed infrastructure. Each node in a MANET is a computer that may be required to act as both a host and a router and, as much, may be required to forward packets between nodes which cannot directly communicate with one another. Each MANET node has much smaller frequency spectrum requirements than that for a node in a fixed infrastructure network. A MANET is an autonomous collection of mobile users that communicate over relatively bandwidth constrained wireless links. Since the nodes are mobile, the network topology may change rapidly and unpredictably over time. The network is decentralized, where all network activity including discovering the topology and delivering messages must be executed by the nodes themselves, i.e., routing functionality will be incorporated into mobile nodes.

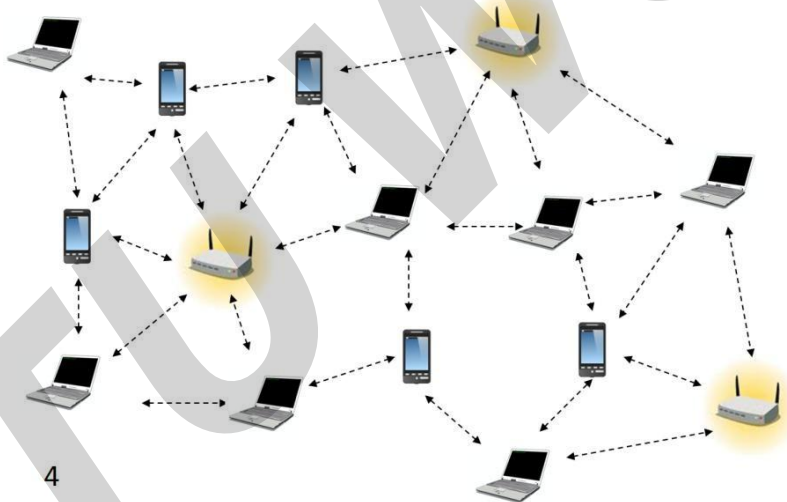

A mobile ad hoc network is a collection of wireless nodes that can dynamically be set up anywhere and anytime without using any pre-existing fixed network infrastructure.

#### MANET- Characteristics

- Dynamic network topology
- Bandwidth constraints and variable link capacity
- Energy constrained nodes
- Multi-hop communications
- Limited security
- Autonomous terminal
- Distributed operation
- Light-weight terminals

### **Need for Ad Hoc Networks**

- ❖ Setting up of fixed access points and backbone infrastructure is not always viable
  - Infrastructure may not be present in a disaster area or war zone
  - Infrastructure may not be practical for short-range radios; Bluetooth (range ~ 10m)
- ❖ Ad hoc networks:
  - Do not need backbone infrastructure support
  - Are easy to deploy
  - Useful when infrastructure is absent, destroyed or impractical

### **Properties of MANETs**

- MANET enables fast establishment of networks. When a new network is to be established, the only requirement is to provide a new set of nodes with limited wireless communication range. A node has limited capability, that is, it can connect only to the nodes which are nearby. Hence it consumes limited power.
- A MANET node has the ability to discover a neighboring node and service. Using a service discovery protocol, a node discovers the service of a nearby node and communicates to a remote node in the MANET.
- MANET nodes have peer-to-peer connectivity among themselves.
- MANET nodes have independent computational, switching (or routing), and communication capabilities.
- The wireless connectivity range in MANETs includes only nearest node connectivity.
- The failure of an intermediate node results in greater latency in communicating with the remote server.
- Limited bandwidth available between two intermediate nodes becomes a constraint for the MANET. The node may have limited power and thus computations need to be energy-efficient.
- There is no access-point requirement in MANET. Only selected access points are provided for connection to other networks or other MANETs.
- MANET nodes can be the iPods, Palm handheld computers, Smartphones, PCs, smart labels, smart sensors, and automobile-embedded systems\
- MANET nodes can use different protocols, for example, IrDA, Bluetooth, ZigBee, 802.11, GSM, and TCP/IP. MANET node performs data caching, saving, and aggregation.
- MANET mobile device nodes interact seamlessly when they move with the nearby wireless nodes, sensor nodes, and embedded devices in automobiles so that the seamless connectivity is maintained between the devices.

## MANET challenges

To design a good wireless ad hoc network, various challenges have to be taken into account:

- Dynamic Topology: Nodes are free to move in an arbitrary fashion resulting in the topology changing arbitrarily. This characteristic demands dynamic configuration of the network.
- Limited security: Wireless networks are vulnerable to attack. Mobile ad hoc networks are more vulnerable as by design any node should be able to join or leave the network at any time. This requires flexibility and higher openness.
- Limited Bandwidth: Wireless networks in general are bandwidth limited. In an ad hoc network, it is all the more so because there is no backbone to handle or multiplex higher bandwidth
- Routing: Routing in a mobile ad hoc network is complex. This depends on many factors, including finding the routing path, selection of routers, topology, protocol etc.

## Applications of MANETS

The set of applications for MANETs is diverse, ranging from small, static networks that are constrained by power sources, to large-scale, mobile, highly dynamic networks. The design of network protocols for these networks is a complex issue. Regardless of the application, MANETs need efficient distributed algorithms to determine network organization, link scheduling, and routing. Some of the main application areas of MANET's are:



- Military battlefield– soldiers, tanks, planes. Ad- hoc networking would allow the military to take advantage of commonplace network technology to maintain an information network between the soldiers, vehicles, and military information headquarters.



- **Sensor networks** – to monitor environmental conditions over a large area
- **Local level** – Ad hoc networks can autonomously link an instant and temporary multimedia network using notebook computers or palmtop computers to spread and share information among participants at e.g. conference or classroom. Another appropriate local level application might be in home networks where devices can communicate directly to exchange information.
- **Personal Area Network (PAN)** – pervasive computing i.e. to provide flexible connectivity between personal electronic devices or home appliances. Short-range MANET can simplify the intercommunication between various mobile devices (such as a PDA, a laptop, and a cellular phone). Tedious wired cables are replaced with wireless connections. Such an ad hoc network can also extend the access to the Internet or other networks by mechanisms e.g. Wireless LAN (WLAN), GPRS, and UMTS.
- **Vehicular Ad hoc Networks** – intelligent transportation i.e. to enable real time vehicle monitoring and adaptive traffic control
- **Civilian environments** – taxi cab network, meeting rooms, sports stadiums, boats, small aircraft
- **Emergency operations** – search and rescue, policing and fire fighting and to provide connectivity between distant devices where the network infrastructure is unavailable. Ad hoc can be used in emergency/rescue operations for disaster relief efforts, e.g. in fire, flood, or earthquake. Emergency rescue operations must take place where non-existing or damaged communications infrastructure and rapid deployment of a communication network is needed. Information is relayed from one rescue team member to another over a small hand held.

### **Routing in MANET's**

Routing in Mobile Ad hoc networks is an important issue as these networks do not have fixed infrastructure and routing requires distributed and cooperative actions from all nodes in the network. MANET's provide point to point routing similar to Internet routing. The major difference between routing in MANET and regular internet is the route discovery mechanism. Internet routing protocols such as RIP or OSPF have relatively long converge times, which is acceptable for a wired network that has infrequent topology changes. However, a MANET has a rapid topology changes due to node mobility making the traditional internet routing protocols inappropriate. MANET-specific routing protocols have been proposed, that handle topology changes well, but they have large control overhead and are not scalable for large networks. Another major difference in the routing is the network address. In internet routing, the network address (IP address) is hierarchical containing a network ID and a computer ID on that network. In contrast, for most MANET's the network address is simply an ID of the node in the network and is not hierarchical. The routing protocol must use the entire address to decide the next hop.

### Some of the fundamental differences between wired networks & ad-hoc networks are:

- Asymmetric links: - Routing information collected for one direction is of no use for the other direction. Many routing algorithms for wired networks rely on a symmetric scenario.
- Redundant links: - In wired networks, some redundancy is present to survive link failures and this redundancy is controlled by a network administrator. In ad-hoc networks, nobody controls redundancy resulting in many redundant links up to the extreme of a complete meshed topology.
- Interference: - In wired networks, links exist only where a wire exists, and connections are planned by network administrators. But, in ad-hoc networks links come and go depending on transmission characteristics, one transmission might interfere with another and nodes might overhear the transmission of other nodes.
- Dynamic topology: - The mobile nodes might move in an arbitrary manner or medium characteristics might change. This result in frequent changes in topology, so snapshots are valid only for a very short period of time. So, in ad-hoc networks, routing tables must somehow reflect these frequent changes in topology and routing algorithms have to be adopted.

### Summary of the difficulties faced for routing in ad-hoc networks

- Traditional routing algorithms known from wired networks will not work efficiently or fail completely. These algorithms have not been designed with a highly dynamic topology, asymmetric links, or interference in mind.
- Routing in wireless ad-hoc networks cannot rely on layer three knowledge alone. Information from lower layers concerning connectivity or interference can help routing algorithms to find a good path.
- Centralized approaches will not really work, because it takes too long to collect the current status and disseminate it again. Within this time the topology has already changed.
- Many nodes need routing capabilities. While there might be some without, at least one router has to be within the range of each node. Algorithms have to consider the limited battery power of these nodes.
- The notion of a connection with certain characteristics cannot work properly. Ad-hoc networks will be connectionless, because it is not possible to maintain a connection in a fast changing environment and to forward data following this connection. Nodes have to make local decisions for forwarding and send packets roughly toward the final destination.
- A last alternative to forward a packet across an unknown topology is flooding. This approach always works if the load is low, but it is very inefficient. A hop counter is needed in each packet to avoid looping, and the diameter of the ad-hoc network.

### Types of MANET Routing Algorithms:

1. Based on the information used to build routing tables :
  - Shortest distance algorithms: algorithms that use distance information to build routing tables.
  - Link state algorithms: algorithms that use connectivity information to build a topology graph that is used to build routing tables.
  
2. Based on when routing tables are built:
  - Proactive algorithms: maintain routes to destinations even if they are not needed. Some of the examples are Destination Sequenced Distance Vector (DSDV), Wireless Routing Algorithm (WRP), Global State Routing (GSR), Source-tree Adaptive Routing (STAR), Cluster-Head Gateway Switch Routing (CGSR), Topology Broadcast Reverse Path Forwarding (TBRPF), Optimized Link State Routing (OLSR) etc.
    - ❖ Always maintain routes:- Little or no delay for route determination
    - ❖ Consume bandwidth to keep routes up-to-date
    - ❖ Maintain routes which may never be used
    - ❖ Advantages: low route latency, State information, QoS guarantee related to connection set-up or other real-time requirements
    - ❖ Disadvantages: high overhead (periodic updates) and route repair depends on update frequency
  
  - Reactive algorithms: maintain routes to destinations only when they are needed. Examples are Dynamic Source Routing (DSR), Ad hoc-On demand distance Vector (AODV), Temporally ordered Routing Algorithm (TORA), Associativity-Based Routing (ABR) etc
    - ❖ only obtain route information when needed
    - ❖ Advantages: no overhead from periodic update, scalability as long as there is only light traffic and low mobility.
    - ❖ Disadvantages: high route latency, route caching can reduce latency
  
  - Hybrid algorithms: maintain routes to nearby nodes even if they are not needed and maintain routes to far away nodes only when needed. Example is Zone Routing Protocol (ZRP).

Which approach achieves a better trade-off depends on the traffic and mobility patterns.

## Destination sequence distance vector (DSDV)

Destination sequence distance vector (DSDV) routing is an example of proactive algorithms and an enhancement to distance vector routing for ad-hoc networks. Distance vector routing is used as routing information protocol (RIP) in wired networks. It performs extremely poorly with certain network changes due to the count-to-infinity problem. Each node exchanges its neighbor table periodically with its neighbors. Changes at one node in the network propagate slowly through the network. The strategies to avoid this problem which are used in fixed networks do not help in the case of wireless ad-hoc networks, due to the rapidly changing topology. This might create loops or unreachable regions within the network.

DSDV adds the concept of sequence numbers to the distance vector algorithm. Each routing advertisement comes with a sequence number. Within ad-hoc networks, advertisements may propagate along many paths. Sequence numbers help to apply the advertisements in correct order. This avoids the loops that are likely with the unchanged distance vector algorithm.

Each node maintains a routing table which stores next hop, cost metric towards each destination and **a sequence number that is created by the destination itself**. Each node periodically forwards routing table to neighbors. Each node **increments and appends its sequence number** when sending its local routing table. Each route is tagged with a sequence number; routes with greater sequence numbers are preferred. Each node advertises a monotonically increasing even sequence number for itself. When a node decides that a route is **broken**, it increments the sequence number of the route and advertises it with infinite metric. Destination advertises new sequence number.

When X receives information from Y about a route to Z,



- ❖ Let destination sequence number for Z at X be  $S(X)$ ,  $S(Y)$  is sent from Y
- ❖ If  $S(X) > S(Y)$ , then X ignores the routing information received from Y
- ❖ If  $S(X) = S(Y)$ , and cost of going through Y is smaller than the route known to X, then X sets Y as the next hop to Z
- ❖ If  $S(X) < S(Y)$ , then X sets Y as the next hop to Z, and  $S(X)$  is updated to equal  $S(Y)$

Besides being loop-free at all times, DSDV has low memory requirements and a quick convergence via triggered updates. Disadvantages of DSDV are, large routing overhead, usage of only bidirectional links and suffers from count to infinity problem.

## Dynamic Source Routing

The Dynamic Source Routing protocol (DSR) is a simple and efficient routing protocol designed specifically for use in multi-hop wireless ad hoc networks of mobile nodes. DSR allows the network to be completely self-organizing and self-configuring, without the need for any existing network infrastructure or administration. The protocol is composed of the two main mechanisms of "Route Discovery" and "Route Maintenance", which work together to allow nodes to discover and maintain routes to arbitrary destinations in the ad hoc network. All aspects of the protocol operate entirely on-demand, allowing the routing packet overhead of DSR to scale automatically to only that needed to react to changes in the routes currently in use.

*Route discovery.* If the source does not have a route to the destination in its route cache, it broadcasts a route request (RREQ) message specifying the destination node for which the route is requested. The RREQ message includes a route record which specifies the sequence of nodes traversed by the message. When an intermediate node receives a RREQ, it checks to see if it is already in the route record. If it is, it drops the message. This is done to prevent routing loops. If the intermediate node had received the RREQ before, then it also drops the message. The intermediate node forwards the RREQ to the next hop according to the route specified in the header. When the destination receives the RREQ, it sends back a route reply message. If the destination has a route to the source in its route cache, then it can send a route response (RREP) message along this route. Otherwise, the RREP message can be sent along the reverse route back to the source. Intermediate nodes may also use their route cache to reply to RREQs. If an intermediate node has a route to the destination in its cache, then it can append the route to the route record in the RREQ, and send an RREP back to the source containing this route. This can help limit flooding of the RREQ. However, if the cached route is out-of-date, it can result in the source receiving stale routes.

*Route maintenance.* When a node detects a broken link while trying to forward a packet to the next hop, it sends a route error (RERR) message back to the source containing the link in error. When an RERR message is received, all routes containing the link in error are deleted at that node.

As an example, consider the following MANET, where a node S wants to send a packet to D, but does not know the route to D. So, it initiates a route discovery. Source node S floods Route Request (RREQ). Each node appends its own identifier when forwarding RREQ as shown below.

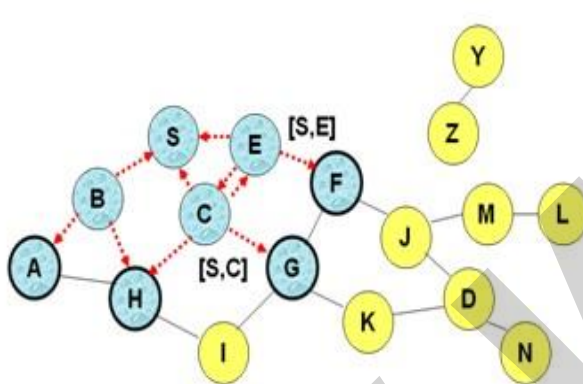
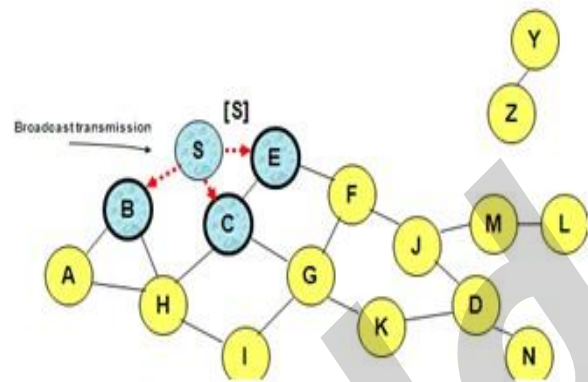
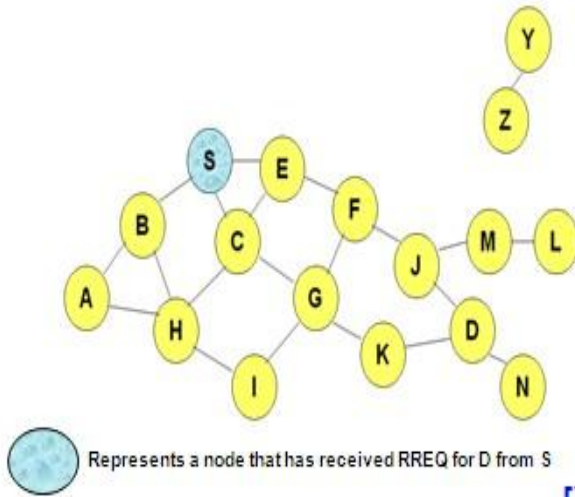

Node H receives packet RREQ from two neighbors:  
potential for collision

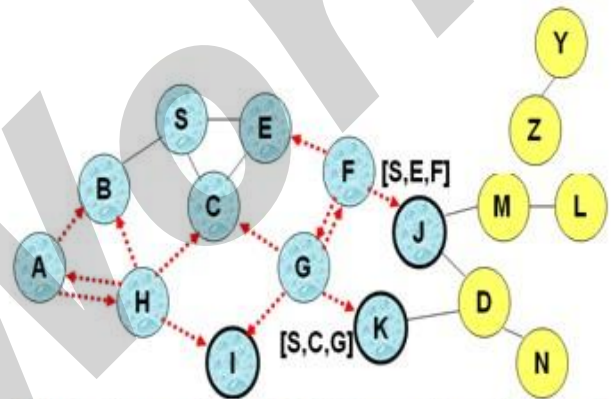

Node C receives RREQ from G and H, but does not forward it again, because node C has already forwarded RREQ once

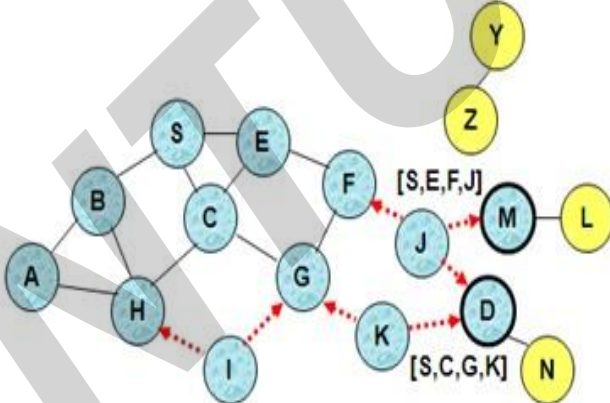

- Nodes J and K both broadcast RREQ to node D
- Since nodes J and K are hidden from each other, their transmissions may collide

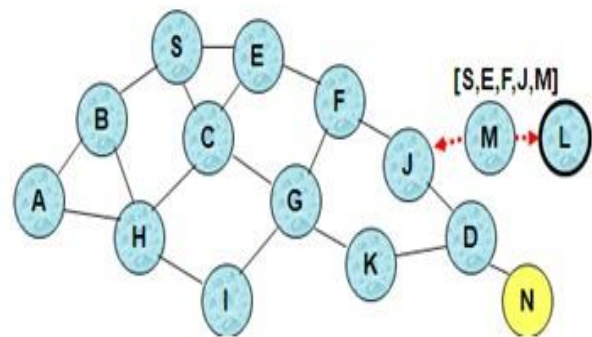

Node D does not forward RREQ, because node D is the intended target of the route discovery

Destination D on receiving the first RREQ, sends a Route Reply (RREP). RREP is sent on a route obtained by reversing the route appended to received RREQ. RREP includes the route from S to D on which RREQ was received by node D.

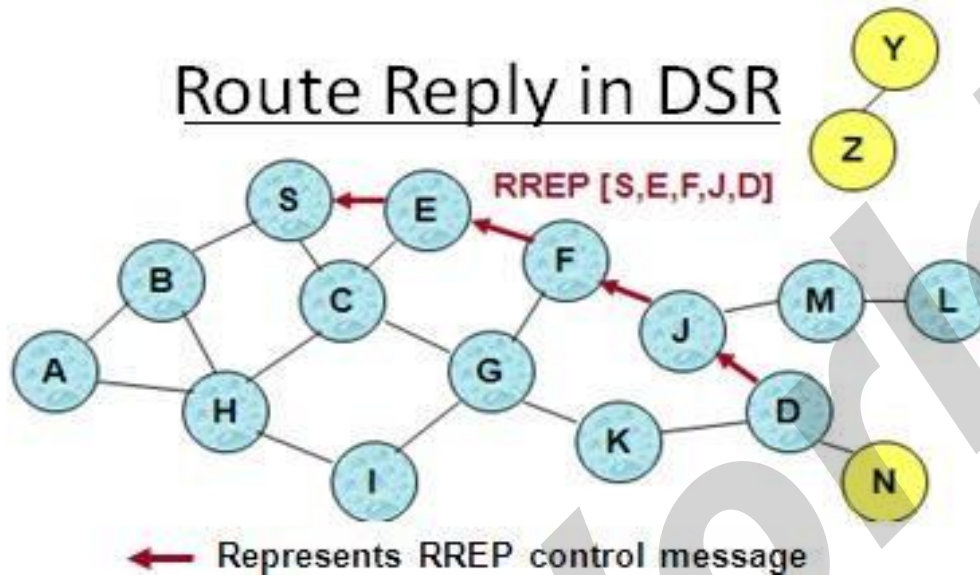

Route Reply can be sent by reversing the route in Route Request (RREQ) only if links are guaranteed to be bi-directional. If Unidirectional (asymmetric) links are allowed, then RREP may need a route discovery from S to D. Node S on receiving RREP, caches the route included in the RREP. When node S sends a data packet to D, the entire route is included in the packet header {hence the name source routing}. Intermediate nodes use the source route included in a packet to determine to whom a packet should be forwarded.

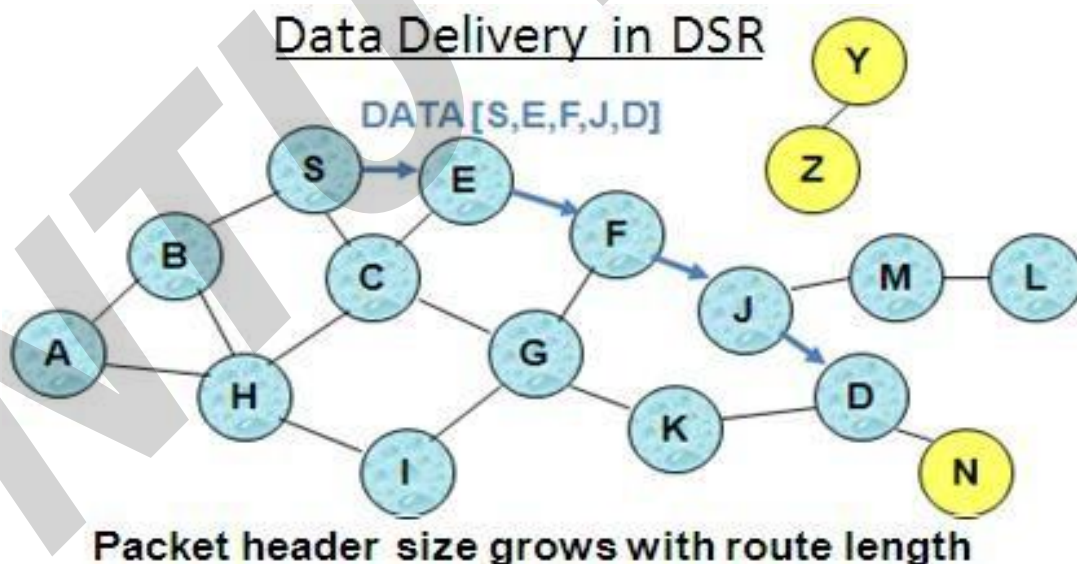

J sends a route error to S along route J-F-E-S when its attempt to forward the data packet S (with route SEFJD) on J-D fails. Nodes hearing RERR update their route cache to remove link J-D

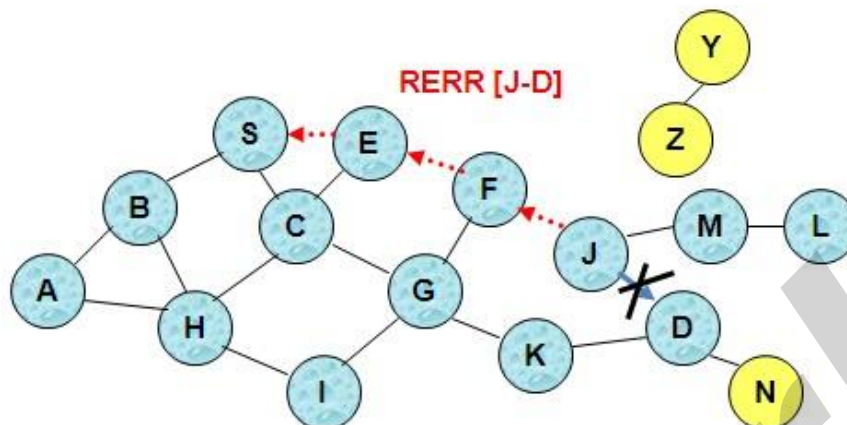

### Advantages of DSR:

- Routes maintained only between nodes who need to communicate-- reduces overhead of route maintenance
- Route caching can further reduce route discovery overhead
- A single route discovery may yield many routes to the destination, due to intermediate nodes replying from local caches

### Disadvantages of DSR:

- Packet header size grows with route length due to source routing
- Flood of route requests may potentially reach all nodes in the network
- Care must be taken to avoid collisions between route requests propagated by neighboring nodes -- insertion of random delays before forwarding RREQ
- Increased contention if too many route replies come back due to nodes replying using their local cache-- Route Reply Storm problem. Reply storm may be eased by preventing a node from sending RREP if it hears another RREP with a shorter route
- An intermediate node may send Route Reply using a stale cached route, thus polluting other caches

An optimization for DSR can be done called as Route Caching. Each node caches a new route it learns by *any means*. In the above example, When node S finds route [S,E,F,J,D] to node D, node S also learns route [S,E,F] to node F. When node K receives Route Request [S,C,G] destined for node, node K learns route [K,G,C,S] to node S. When node F forwards Route Reply RREP [S,E,F,J,D], node F learns route [F,J,D] to node D. When node E forwards Data [S,E,F,J,D] it learns route [E,F,J,D] to node D. A node may also learn a route when it overhears Data packets. Usage of Route cache can speed up route discovery and can also reduce propagation of route



requests. The disadvantages are, stale caches can adversely affect performance. With passage of time and host mobility, cached routes may become invalid.

### **Ad Hoc On-Demand Distance Vector Routing (AODV)**

AODV is another reactive protocol as it reacts to changes and maintains only the active routes in the caches or tables for a pre-specified expiration time. Distance vector means a set of distant nodes, which defines the path to destination. AODV can be considered as a descendant of DSR and DSDV algorithms. It uses the same route discovery mechanism used by DSR. DSR includes source routes in packet headers and resulting large headers can sometimes degrade performance, particularly when data contents of a packet are small. AODV attempts to improve on DSR by maintaining routing tables at the nodes, so that data packets do not have to contain routes. AODV retains the desirable feature of DSR that routes are maintained only between nodes which need to communicate. However, as opposed to DSR, which uses source routing, AODV uses hop-by-hop routing by maintaining routing table entries at intermediate nodes.

*Route Discovery.* The route discovery process is initiated when a source needs a route to a destination and it does not have a route in its routing table. To initiate route discovery, the source floods the network with a RREQ packet specifying the destination for which the route is requested. When a node receives an RREQ packet, it checks to see whether it is the destination or whether it has a route to the destination. If either case is true, the node generates an RREP packet, which is sent back to the source along the reverse path. Each node along the reverse path sets up a forward pointer to the node it received the RREP from. This sets up a forward path from the source to the destination. If the node is not the destination and does not have a route to the destination, it rebroadcasts the RREQ packet. At intermediate nodes duplicate RREQ packets are discarded. When the source node receives the first RREP, it can begin sending data to the destination. To determine the relative degree out-of-datedness of routes, each entry in the node routing table and all RREQ and RREP packets are tagged with a destination sequence number. A larger destination sequence number indicates a more current (or more recent) route. Upon receiving an RREQ or RREP packet, a node updates its routing information to set up the reverse or forward path, respectively, only if the route contained in the RREQ or RREP packet is more current than its own route.

*Route Maintenance.* When a node detects a broken link while attempting to forward a packet to the next hop, it generates a RERR packet that is sent to all sources using the broken link. The RERR packet erases all routes using the link along the way. If a source receives a RERR packet and a route to the destination is still required, it initiates a new route discovery process. Routes are also deleted from the routing table if they are unused for a certain amount of time.

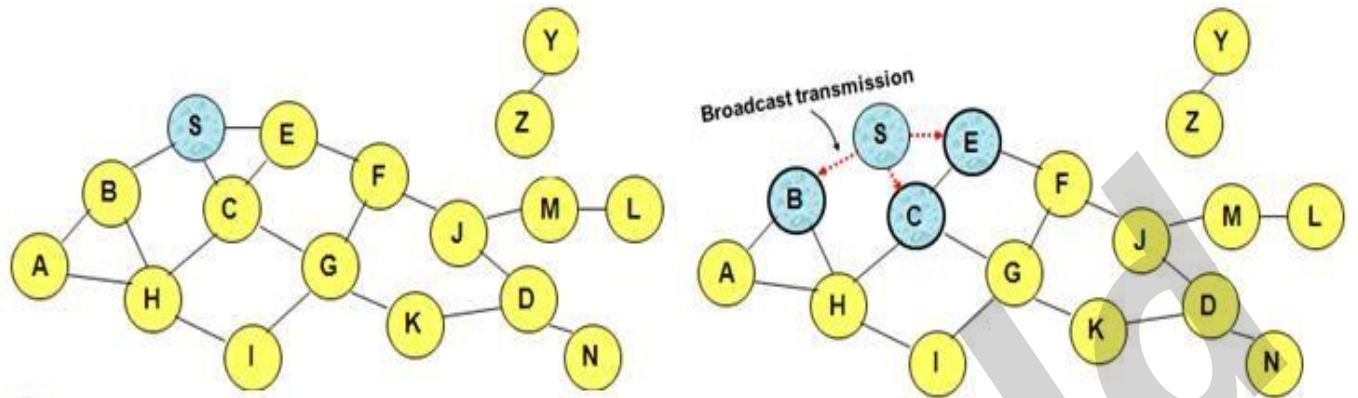

 Represents a node that has received RREQ for D from S

 Represents transmission of RREQ

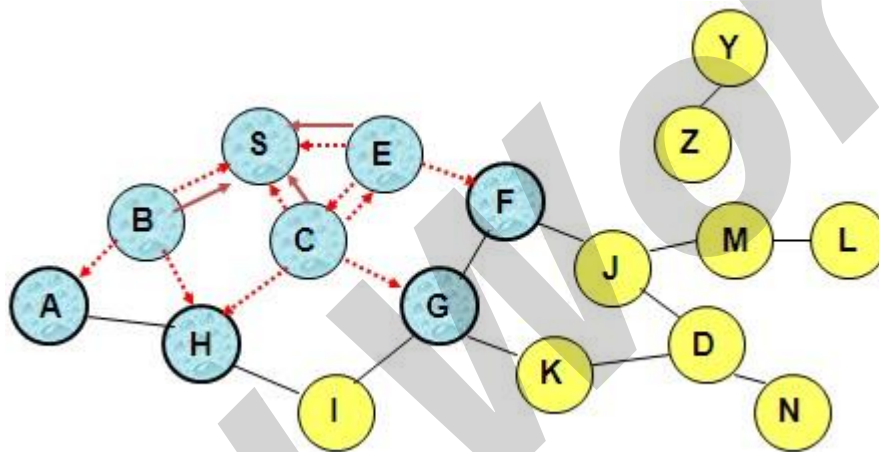

 Represents links on Reverse Path

### Reverse Path Setup in AODV

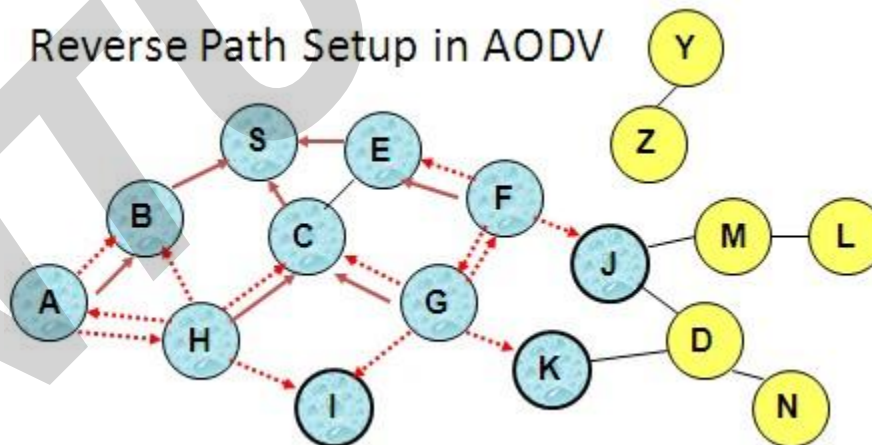

Node C receives RREQ from G and H, but does not forward it again, because node C has **already forwarded RREQ once**

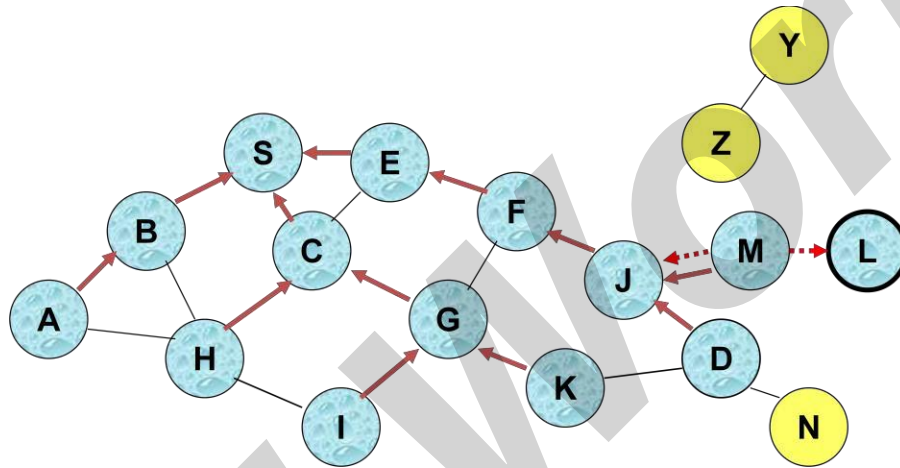
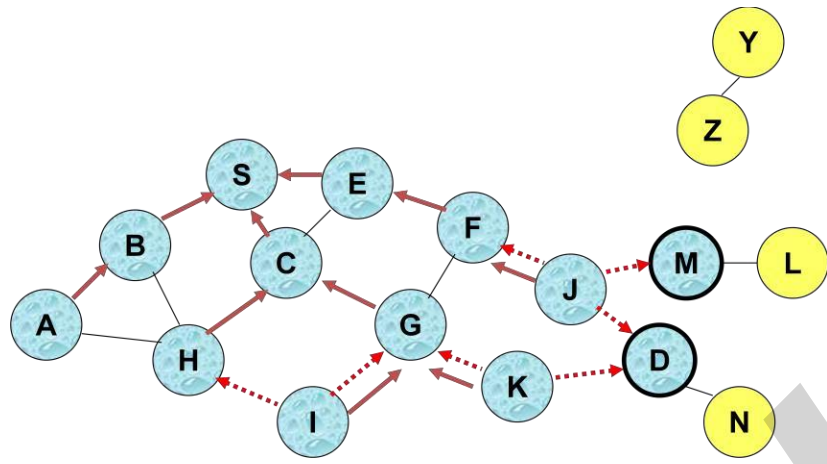

**Node D does not forward RREQ**, because node D is the intended target of the RREQ

### Route Reply in AODV

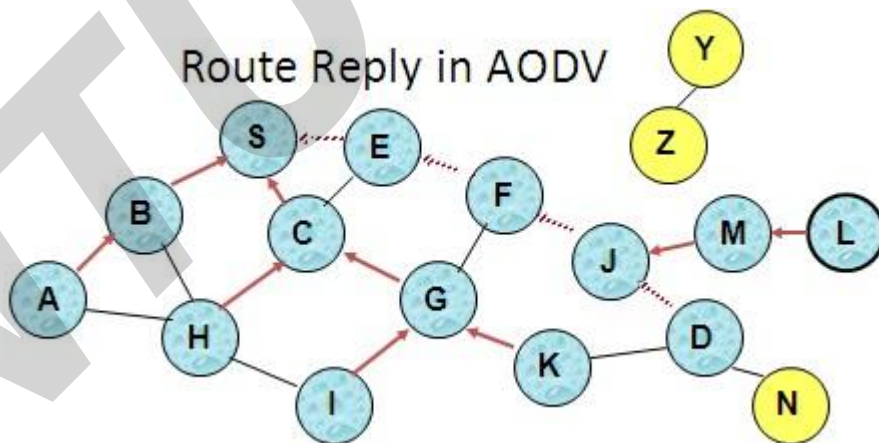

**.....** Represents links on path taken by RREP

An intermediate node (not the destination) may also send a Route Reply (RREP) provided that it knows a more recent path than the one previously known to sender S. To determine whether the path known to an intermediate node is more recent, *destination sequence numbers* are used. The likelihood that an intermediate node will send a Route Reply when using AODV is not as high as DSR. A new Route Request by node S for a destination is assigned a higher destination sequence number. An intermediate node which knows a route, but with a smaller sequence number, cannot send Route Reply

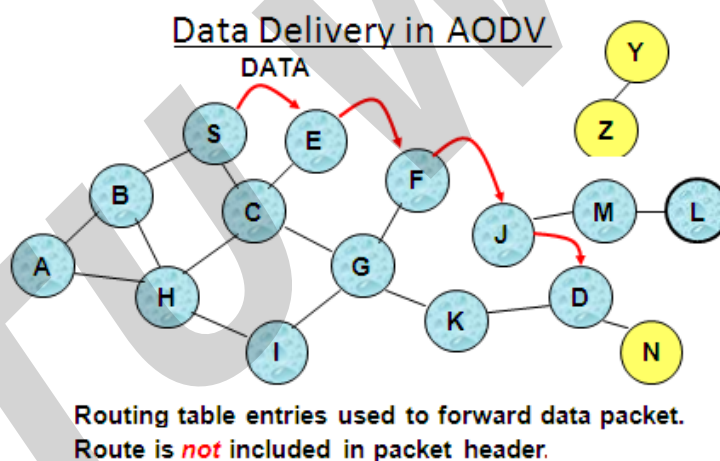
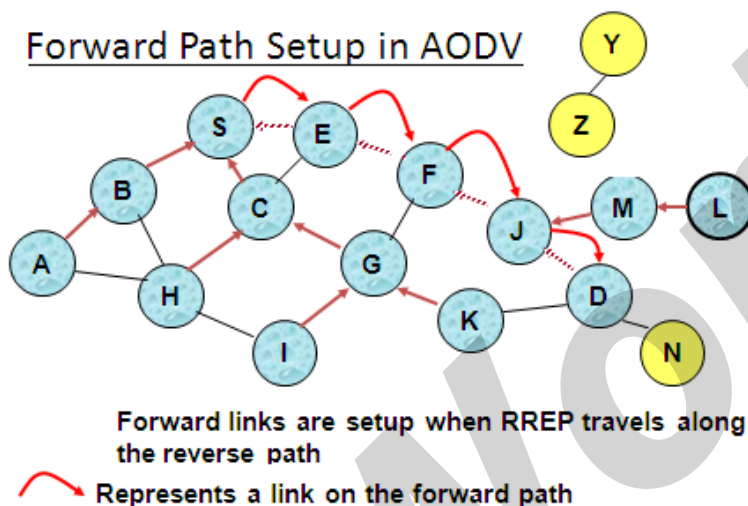

When node X is unable to forward packet P (from node S to node D) on link (X,Y), it generates a RERR message. Node X increments the destination sequence number for D cached at node X. The incremented sequence number  $N$  is included in the RERR. When node S receives the RERR, it initiates a new route discovery for D using destination sequence number at least as large as  $N$ . When node D receives the route request with destination sequence number  $N$ , node D will set its sequence number to  $N$ , unless it is already larger than  $N$ .

Sequence numbers are used in AODV to avoid using old/broken routes and to determine which route is newer. Also, it prevents formation of loops.

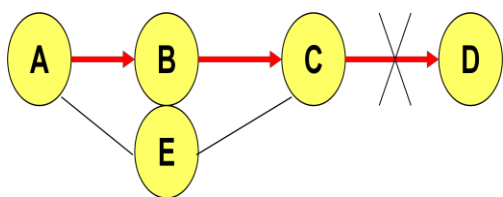

Assume that A does not know about failure of link C-D because RERR sent by C is lost.

Now C performs a route discovery for D. Node A receives the RREQ (say, via path C-E-A)

Node A will reply since A knows a route to D via node B resulting in a loop (for instance, C-E-A-B-C)

Neighboring nodes periodically exchange hello message and absence of hello message indicates a link failure. When node X is unable to forward packet P (from node S to node D) on link (X,Y), it generates a **RERR message**. Node X increments the destination sequence number for D cached at node X. The incremented sequence number  $N$  is included in the RERR. When node S receives the RERR, it initiates a new route discovery for D using destination sequence number at least as large as  $N$ . When node D receives the route request with destination sequence number  $N$ , node D will set its sequence number to  $N$ , unless it is already larger than  $N$ .

### Another example for AODV protocol:

Assume node-1 want to send a msg to node-14 and does not know the route. So, it broadcasts (floods) route request message, shown in red.

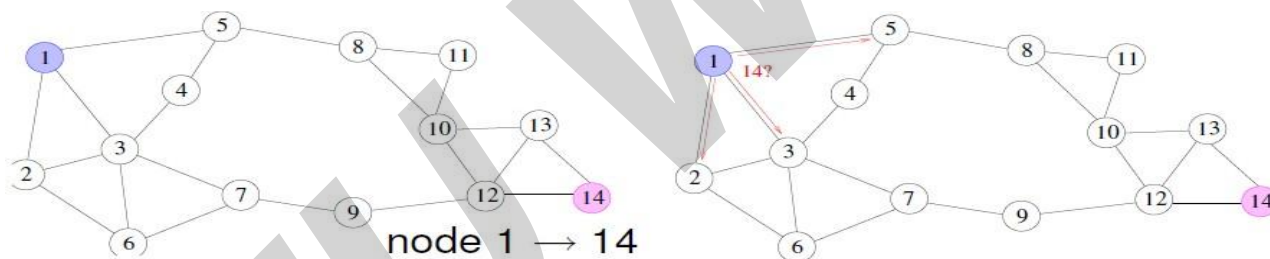

Node from which RREQ was received defines a reverse route to the source. (reverse routing table entries shown in blue).

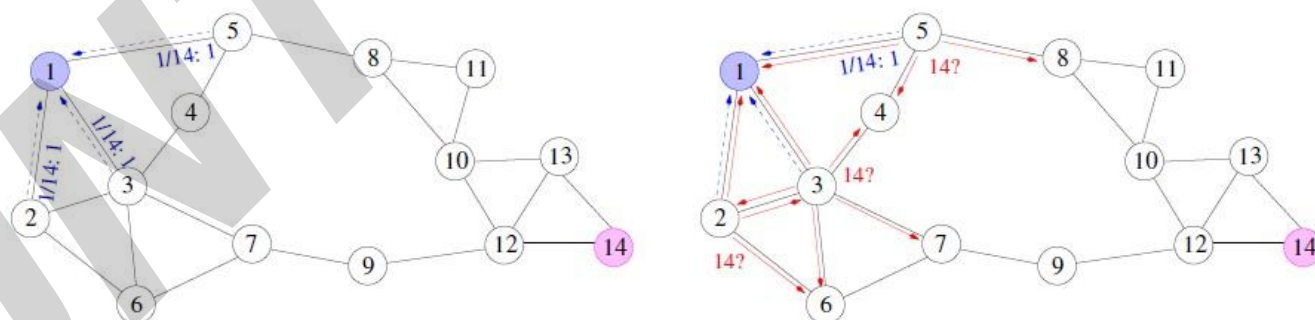

The route request is flooded through the network. Destination managed sequence number, ID prevent looping. Also, flooding is expensive and creates broadcast collision problem.

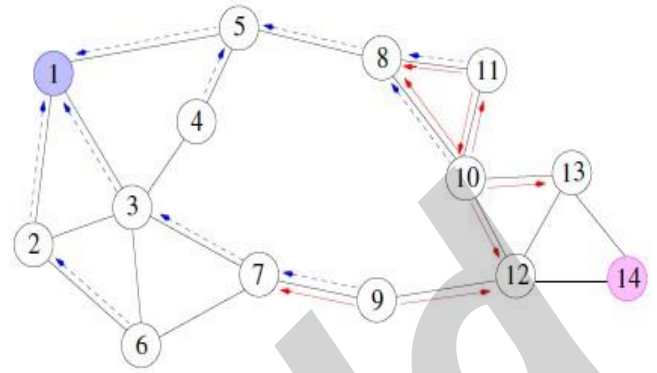
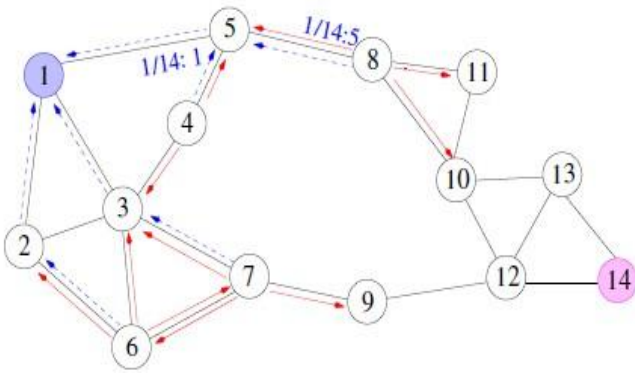

Route request arrives at the destination node-14. Upon receiving, destination sends route reply by setting a sequence number (shown in pink)

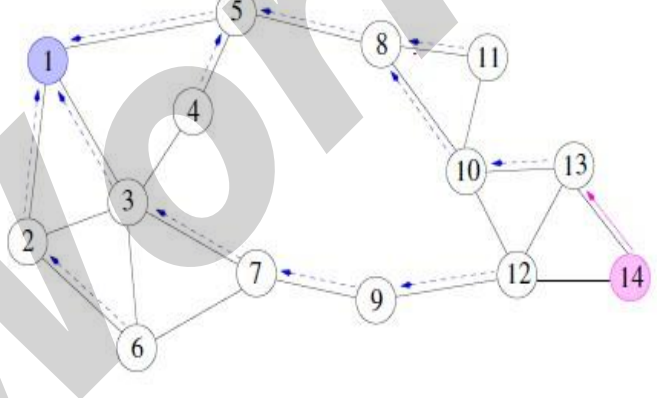
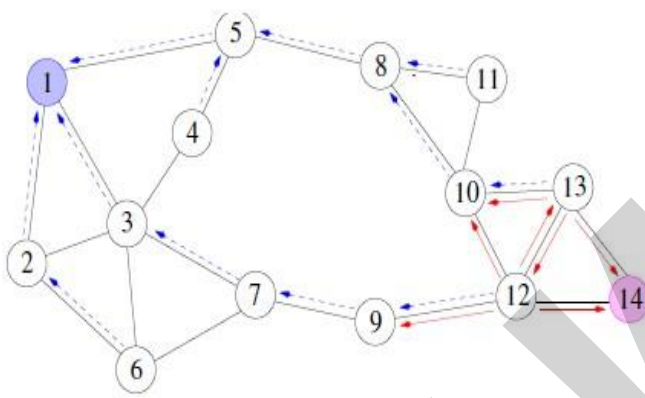

Routing table now contains forward route to the destination. Route reply follows reverse route back to the source.

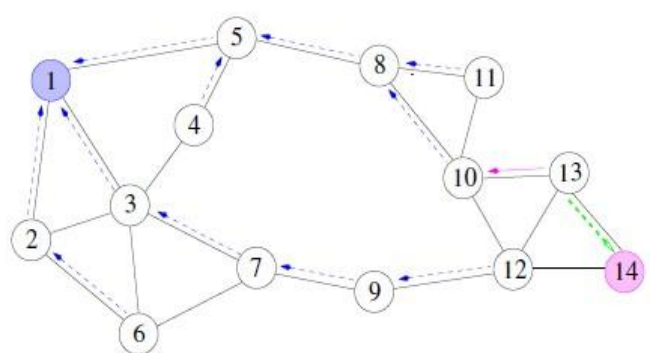
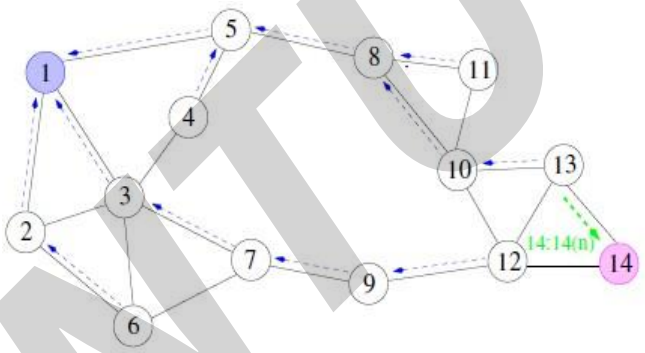

The route reply sets the forward table entries on its way back to the source.

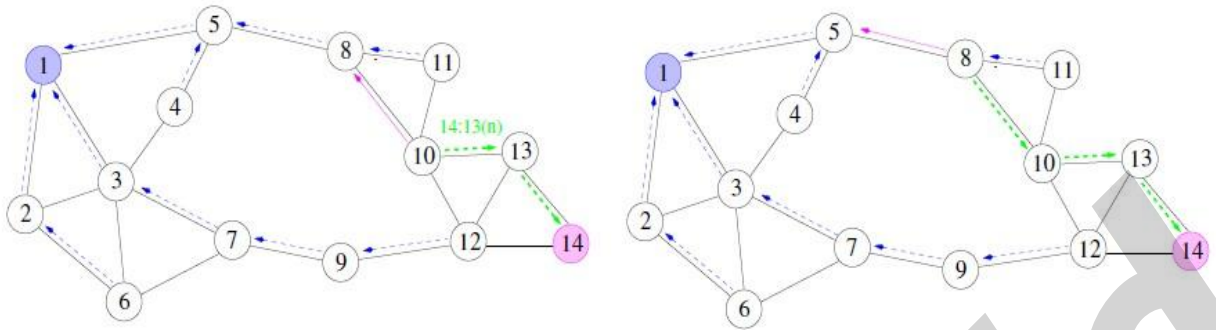

Once the route reply reaches the source, it adopts the destination sequence number. Traffic flows along the forward route. Forward route is refreshed and the reverse routes get timed out.

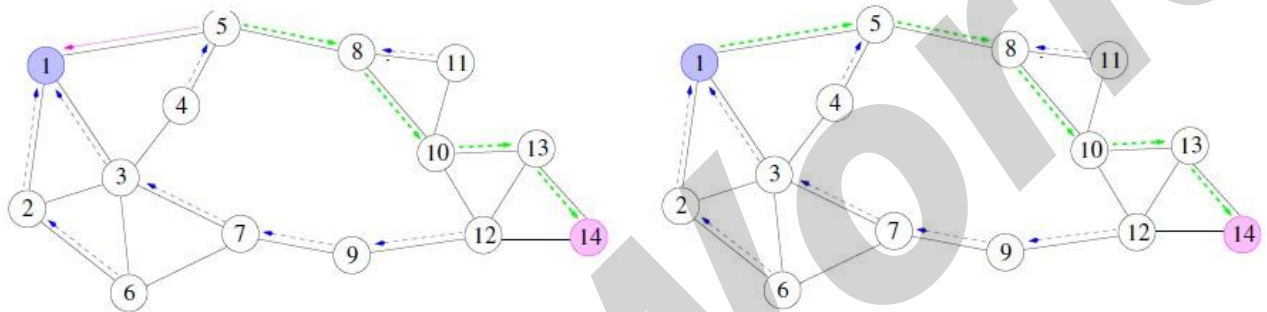

Suppose there has been a failure in one of the links. The node sends a return error message to the source with incrementing the sequence number.

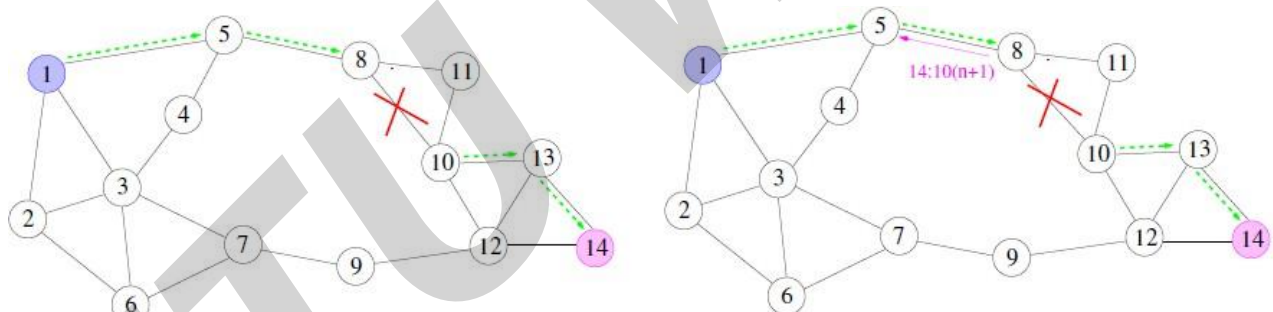

Once the source receives the route error, it re-initiates the route discovery process.

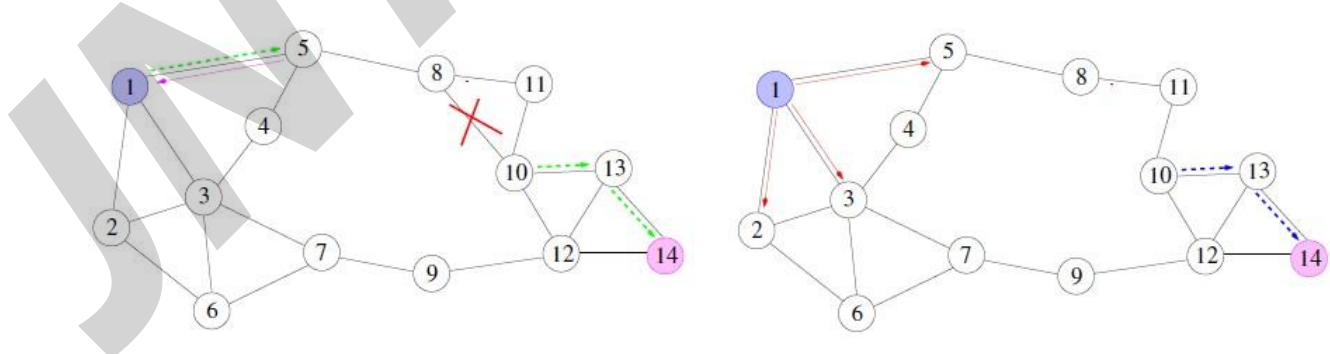

A routing table entry maintaining a reverse path is purged after a timeout interval. Timeout should be long enough to allow RREP to come back. A routing table entry maintaining a forward path is purged if *not used* for a *active\_route\_timeout* interval. If no data is being sent using a particular routing table entry, that entry will be deleted from the routing table (even if the route may actually still be valid).

### Cluster-head Gateway Switch Routing (CGSR)

The cluster-head gateway switch routing (CGSR) is a hierarchical routing protocol. It is a proactive protocol. When a source routes the packets to destination, the routing tables are already available at the nodes. A cluster higher in hierarchy sends the packets to the cluster lower in hierarchy. Each cluster can have several daughters and forms a tree-like structure in CGSR. CGSR forms a cluster structure. The nodes aggregate into clusters using an appropriate algorithm. The algorithm defines a cluster-head, the node used for connection to other clusters. It also defines a gateway node which provides switching (communication) between two or more cluster-heads. There will thus be three types of nodes— (i) internal nodes in a cluster which transmit and receive the messages and packets through a cluster-head, (ii) cluster-head in each cluster such that there is a cluster-head which dynamically schedules the route paths. It controls a group of ad-hoc hosts, monitors broadcasting within the cluster, and forwards the messages to another cluster-head, and (iii) gateway node to carry out transmission and reception of messages and packets between cluster-heads of two clusters.

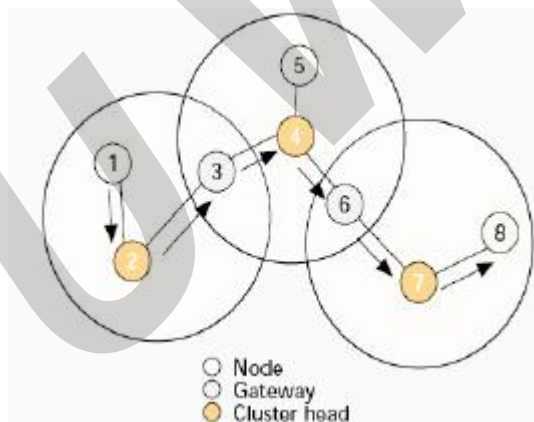

The cluster structure leads to a higher performance of the routing protocol as compared to other protocols because it provides gateway switch-type traffic redirections and clusters provide an effective membership of nodes for connectivity.

CGSR works as follow:

- periodically, every nodes sends a hello message containing its ID and a monotonically increasing sequence number



- Using these messages, every cluster-head maintains a table containing the IDs of nodes belonging to it and their most recent sequence numbers.
- Cluster-heads exchange these tables with each other through gateways; eventually, each node will have an entry in the affiliation table of each cluster-head. This entry shows the node's ID & cluster-head of that node.
- Each cluster-head and each gateway maintains a routing table with an entry for every cluster-head that shows the next gateway on the shortest path to that cluster head.

#### **Disadvantages:**

- The same disadvantage common to all hierarchal algorithms related to cluster formation and maintenance.

#### **Hierarchal State Routing (HSR)**

A hierarchal link state routing protocol that solves the location management problem found in MMWN by using the logical subnets. A logical subnet is : a group of nodes that have common characteristics (e.g. the subnet of students, the subnet of profs , employees etc. ). Nodes of the same subnet do not have to be close to each other in the physical distance.

HSR procedure:

1. Based on the physical distance, nodes are grouped into clusters that are supervised by cluster-heads. There are more than one level of clustering.
2. Every node has two addresses :
  - I. a hierarchal-ID ,(HID), composed of the node's MAC address prefixed by the IDs of its parent clusters.
  - II. a logical address in the form <subnet,host>.
3. Every logical subnet has a home agent, i.e. a node that keeps track of the HID of all members of that subnet.
4. The HIDs of the home agents are known to all the cluster-heads, and the cluster-head can translate the subnet part of the node's logical address to the HID of the corresponding home agent.
5. when a node moves to a new cluster, the head of the cluster detects it and informs the node's home agents about node's new HID.
6. When a home agent moves to a new cluster, the head of the cluster detects it and informs all other cluster-heads about the home agent's new HID.

To start a session:

1. The source node informs its cluster-head about the logical address of the destination node.

2. The cluster-head looks up the HID of the destination node's home agent and uses it to send query to the home agent asking about the destination's HID.
3. After knowing the destination's HID, the cluster-head uses its topology map to find a route to the destination's cluster-head.

**Disadvantages:** cluster formation and maintenance.

### Optimized Link State Routing Protocol

Optimized link state routing protocol (OLSR) has characteristics similar to those of link state flat routing table driven protocol, but in this case, only required updates are sent to the routing database. This reduces the overhead control packet size and numbers.

OLSR uses controlled flood to disseminate the link state information of each node.

- Every node creates a list of its one hop neighbors.
- Neighbor nodes exchange their lists with each other.
- Based on the received lists, each node creates its MPR.

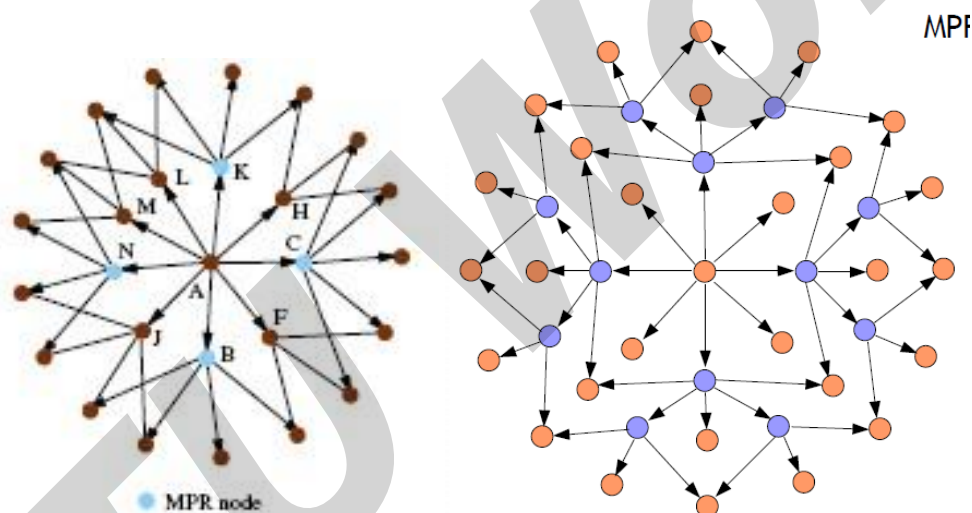

The multipoint relays of each node, (MPR), is the minimal set of 1-hop nodes that covers all 2-hop points.

- The members of the MPR are the only nodes that can retransmit the link state information in an attempt to limit the flood.

### Security in MANET's

Securing wireless ad-hoc networks is a highly challenging issue. Understanding possible form of attacks is always the first step towards developing good security solutions. Security of communication in MANET is important for secure transmission of information. Absence of any central co-ordination mechanism and shared wireless medium makes MANET more vulnerable

to digital/cyber attacks than wired network there are a number of attacks that affect MANET. These attacks can be classified into two types:

**1. External Attack:** External attacks are carried out by nodes that do not belong to the network. It causes congestion sends false routing information or causes unavailability of services.

**2. Internal Attack:** Internal attacks are from compromised nodes that are part of the network. In an internal attack the malicious node from the network gains unauthorized access and impersonates as a genuine node. It can analyze traffic between other nodes and may participate in other network activities.

- ❖ **Denial of Service attack:** This attack aims to attack the availability of a node or the entire network. If the attack is successful the services will not be available. The attacker generally uses radio signal jamming and the battery exhaustion method.
- ❖ **Impersonation:** If the authentication mechanism is not properly implemented a malicious node can act as a genuine node and monitor the network traffic. It can also send fake routing packets, and gain access to some confidential information.
- ❖ **Eavesdropping:** This is a passive attack. The node simply observes the confidential information. This information can be later used by the malicious node. The secret information like location, public key, private key, password etc. can be fetched by eavesdropper.
- ❖ **Routing Attacks:** The malicious node makes routing services a target because it's an important service in MANETs. There are two flavors to this routing attack. One is attack on routing protocol and another is attack on packet forwarding or delivery mechanism. The first is aimed at blocking the propagation of routing information to a node. The latter is aimed at disturbing the packet delivery against a predefined path.
- ❖ **Black hole Attack:** In this attack, an attacker advertises a zero metric for all destinations causing all nodes around it to route packets towards it.[9] A malicious node sends fake routing information, claiming that it has an optimum route and causes other good nodes to route data packets through the malicious one. A malicious node drops all packets that it receives instead of normally forwarding those packets. An attacker listen the requests in a flooding based protocol.
- ❖ **Wormhole Attack:** In a wormhole attack, an attacker receives packets at one point in the network, —tunnels them to another point in the network, and then replays them into the network from that point. Routing can be disrupted when routing control message are tunnelled. This tunnel between two colluding attacks is known as a wormhole.
- ❖ **Replay Attack:** An attacker that performs a replay attack are retransmitted the valid data repeatedly to inject the network routing traffic that has been captured previously. This attack usually targets the freshness of routes, but can also be used to undermine poorly designed security solutions.

- ❖ **Jamming:** In jamming, attacker initially keep monitoring wireless medium in order to determine frequency at which destination node is receiving signal from sender. It then transmit signal on that frequency so that error free receptor is hindered.
- ❖ **Man- in- the- middle attack:** An attacker sits between the sender and receiver and sniffs any information being sent between two nodes. In some cases, attacker may impersonate the sender to communicate with receiver or impersonate the receiver to reply to the sender.
- ❖ **Gray-hole attack:** This attack is also known as routing misbehavior attack which leads to dropping of messages. Gray-hole attack has two phases. In the first phase the node advertise itself as having a valid route to destination while in second phase, nodes drops intercepted packets with a certain probability.

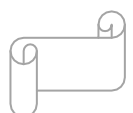
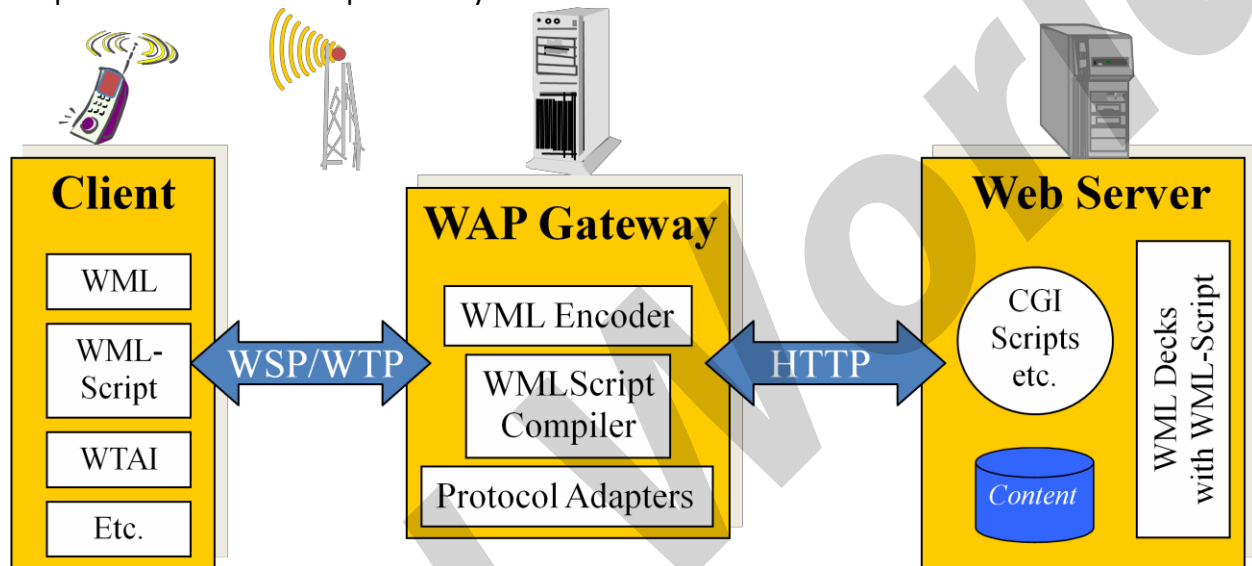

## Unit-8

The Wireless Application Protocol (WAP) is an open, global specification that empowers mobile users with wireless devices to easily access and interact with information and services instantly.

WAP is a global standard and is not controlled by any single company. Ericsson, Nokia, Motorola, and Unwired Planet founded the **WAP Forum** in the summer of 1997 with the initial purpose of defining an industry-wide specification for developing applications over wireless communications networks. The WAP specifications define a set of protocols in application, session, transaction, security, and transport layers, which enable operators, manufacturers, and applications providers to meet the challenges in advanced wireless service differentiation and fast/flexible service creation.

All solutions must be:

- **interoperable**, i.e., allowing terminals and software from different vendors to communicate with networks from different providers
- **scaleable**, i.e., protocols and services should scale with customer needs and number of customers
- **efficient**, i.e., provision of QoS suited to the characteristics of the wireless and mobile networks

- **reliable**, i.e., provision of a consistent and predictable platform for deploying services; and
- **secure**, i.e., preservation of the integrity of user data, protection of devices and services from security problems.

### **Why Choose WAP?**

In the past, wireless Internet access has been limited by the capabilities of handheld devices and wireless networks.

- ❖ WAP utilizes Internet standards such as XML, user datagram protocol (UDP), and Internet protocol (IP). Many of the protocols are based on Internet standards such as hypertext transfer protocol (HTTP) and TLS but have been optimized for the unique constraints of the wireless environment: low bandwidth, high latency, and less connection stability.
- ❖ Internet standards such as hypertext markup language (HTML), HTTP, TLS and transmission control protocol (TCP) are inefficient over mobile networks, requiring large amounts of mainly text-based data to be sent. Standard HTML content cannot be effectively displayed on the small-size screens of pocket-sized mobile phones and pagers.
- ❖ WAP utilizes binary transmission for greater compression of data and is optimized for long latency and low bandwidth. WAP sessions cope with intermittent coverage and can operate over a wide variety of wireless transports.
- ❖ WML and wireless markup language script (WML Script) are used to produce WAP content. They make optimum use of small displays, and navigation may be performed with one hand. WAP content is scalable from a two-line text display on a basic device to a full graphic screen on the latest smart phones and communicators.
- ❖ The lightweight WAP protocol stack is designed to minimize the required bandwidth and maximize the number of wireless network types that can deliver WAP content. Multiple networks will be targeted, with the additional aim of targeting multiple networks. These include global system for mobile communications (GSM) 900, 1,800, and 1,900 MHz; interim standard (IS)-136; digital European cordless communication (DECT); time-division multiple access (TDMA), personal communications service (PCS), FLEX, and code division multiple access (CDMA). All network technologies and bearers will also be supported, including short message service (SMS), USSD, circuit-switched cellular data (CSD), cellular digital packet data (CDPD), and general packet radio service (GPRS).
- ❖ As WAP is based on a scalable layered architecture, each layer can develop independently of the others. This makes it possible to introduce new bearers or to use new transport protocols without major changes in the other layers.

- ❖ WAP will provide multiple applications, for business and customer markets such as banking, corporate database access, and a messaging interface.

## WAP Architecture

The following figure gives an overview of the WAP architecture, its protocols and components, and compares this architecture with the typical internet architecture when using the World Wide Web. The basis for transmission of data is formed by different **bearer services**. WAP does not specify bearer services, but uses existing data services and will integrate further services. Examples are message services, such as short message service (SMS) of GSM, circuit-switched data, such as high-speed circuit switched data (HSCSD) in GSM, or packet switched data, such as general packet radio service (GPRS) in GSM. Many other bearers are supported, such as CDPD, IS-136, PHS.

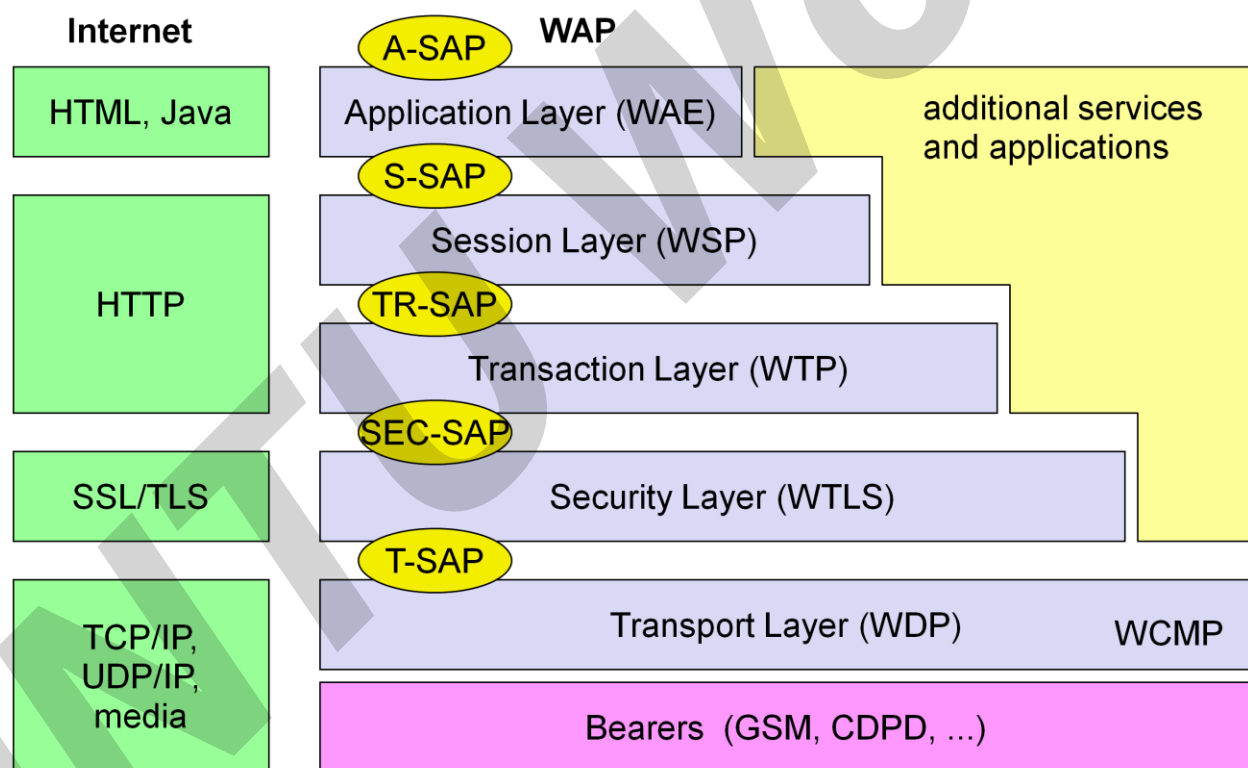

WAE comprises WML (Wireless Markup Language), WML Script, WTAI etc.

The WAP datagram protocol (WDP) and the additional Wireless control message protocol (WCMP) is the transport layer that sends and receives messages via any available bearer network, including SMS, USSD, CSD, CDPD, IS-136 packet data, and GPRS. The **transport layer**

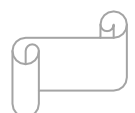

**service access point (T-SAP)** is the common interface to be used by higher layers independent of the underlying network.

**WTLS:** The next higher layer, the security layer with its wireless transport layer security protocol WTLS offers its service at the **security SAP (SEC-SAP)**. WTLS is based on transport layer security (TLS, formerly SSL, secure sockets layer). WTLS has been optimized for use in wireless networks with narrow-band channels. It can offer data integrity, privacy, authentication, and (some) denial-of-service protection.

**WTP:** The WAP transaction protocol (WTP) layer provides transaction support, adding reliability to the datagram service provided by WDP at the **transaction SAP (TR-SAP)**.

**WSP:** The session layer with the wireless session protocol (WSP) currently offers two services at the session-SAP (S-SAP), one connection-oriented and one connectionless if used directly on top of WDP. A special service for browsing the web (WSP/B) has been defined that offers HTTP/1.1 functionality, long-lived session state, session suspend and resume, session migration and other features needed for wireless mobile access to the web.

**WAE:** The application layer with the wireless application environment (WAE) offers a framework for the integration of different www and mobile telephony applications.

### Working of WAP

WAP does not always force all applications to use the whole protocol architecture. Applications can use only a part of the architecture. For example, if an application does not require security but needs the reliable transport of data, it can **directly** use a service of the transaction layer. Simple applications can directly use WDP.



Different scenarios are possible for the integration of WAP components into existing wireless and fixed networks. On the left side, different fixed networks, such as the traditional internet and the public switched telephone network (PSTN), are shown. One cannot change protocols and services of these existing networks so several new elements will be implemented between these networks and the WAP-enabled wireless, mobile devices in a wireless network on the right-hand side.

## Wireless Datagram Protocol (WDP)

**Wireless Datagram Protocol** defines the movement of information from receiver to the sender and resembles the User Datagram Protocol in the Internet protocol suite.

WDP offers a consistent service at the Transport Service Access Point to the upper layer protocol of WAP. This consistency of service allows for applications to operate transparently over different available bearer services. WDP can be mapped onto different bearers, with different characteristics. In order to optimise the protocol with respect to memory usage and radio transmission efficiency, the protocol performance over each bearer may vary.

WDP offers **source** and **destination port numbers** used for multiplexing and demultiplexing of data respectively. The service primitive to send a datagram is **TUnitdata.req** with the **destination address (DA)**, **destination port (DP)**, **Source address (SA)**, **source port (SP)**, and **user data (UD)** as mandatory parameters. Destination and source address are unique addresses for the receiver and sender of the user data. These could be MSISDNs (i.e., a telephone number), IP addresses, or any other unique identifiers. The **T-DUnitdata.ind** service primitive indicates the reception of data. Here destination address and port are only optional parameters.

#### WDP service primitives

If a higher layer requests a service the WDP cannot fulfil, this error is indicated with the **T-DError.ind** service primitive. An **error code (EC)** is returned indicating the reason for the error to the higher layer. WDP is not allowed to use this primitive to indicate problems with the bearer service. It is only allowed to use the primitive to indicate local problems, such as a user data size that is too large. If any errors happen when WDP datagrams are sent from one WDP entity to another, the **wireless control message protocol (WCMP)** provides error handling mechanisms for WDP and should therefore be implemented. WCMP contains control messages that resemble the internet control message protocol messages and can also be used for diagnostic and informational purposes. WCMP can be used by WDP nodes and gateways to report errors.

Typical WCMP messages are **destination unreachable** (route, port, address unreachable), **parameter problem** (errors in the packet header), **message too big**, **reassembly failure**, or **echo request/reply**. An additional **WDP management entity** supports WDP and provides information about changes in the environment, which may influence the correct operation of WDP.

## Wireless Transport Layer Security (WTLS)

WTLS can provide different levels of security (for privacy, data integrity, and authentication) and has been optimized for low bandwidth, high-delay bearer networks. WTLS takes into account the low processing power and very limited memory capacity of the mobile devices for cryptographic algorithms. WTLS supports datagram and connection-oriented transport layer protocols. WTLS took over many features and mechanisms from TLS, but it has an optimized handshaking between the peers.

Before data can be exchanged via WTLS, a secure session has to be established. This session establishment consists of several steps: The following figure illustrates the sequence of service primitives needed for a so-called 'full handshake'.

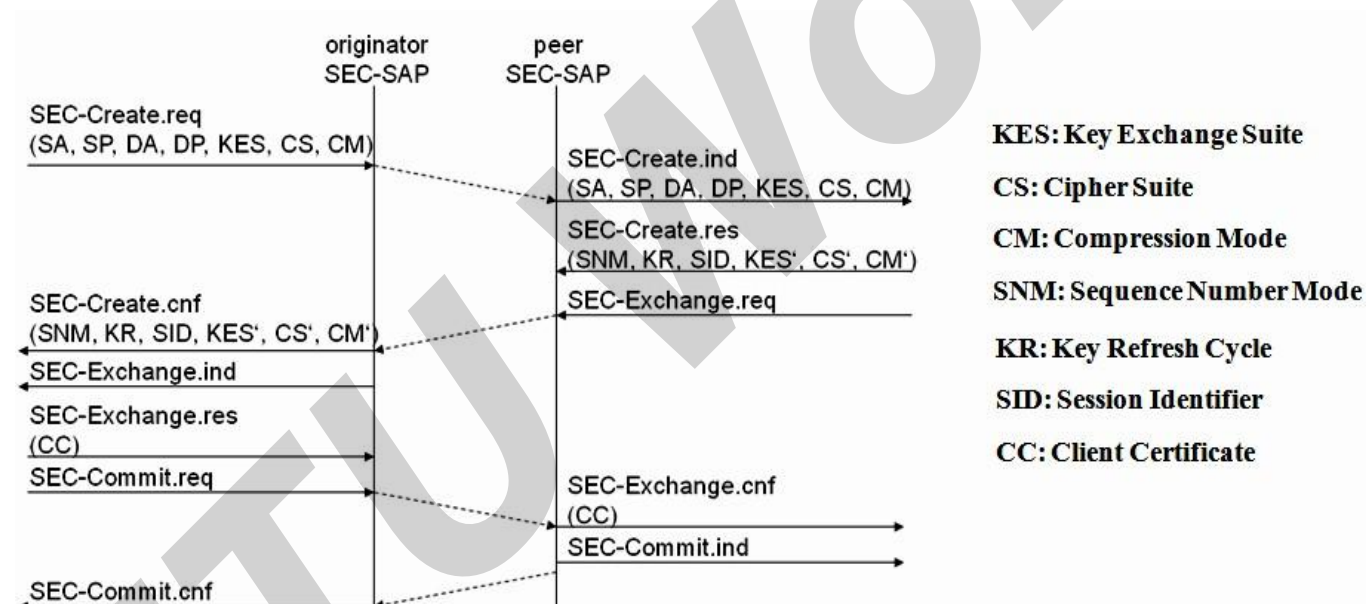

The first step is to initiate the session with the **SEC-Create** primitive. Parameters are **source address (SA)**, **source port (SP)** of the originator, **destination address (DA)**, **destination port (DP)** of the peer. The originator proposes a **key exchange suite (KES)** (e.g., RSA, DH, ECC), a **cipher suite (CS)** (e.g., DES, IDEA), and a **compression method (CM)**. The peer answers with parameters for the **sequence number mode (SNM)**, the **key refresh cycle (KR)** (i.e., how often keys are refreshed within this secure session), the **session identifier (SID)** (which is unique with each peer), and the selected **key exchange suite (KES')**, **cipher suite (CS')**, **compression method (CM')**. The peer also issues a **SEC-Exchange** primitive. This indicates that the peer wishes to perform public-key authentication with the client, i.e., the peer

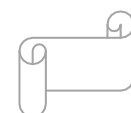

requests a **client certificate (CC)** from the originator. The first step of the secure session creation, the negotiation of the security parameters and suites, is indicated on the originator's side, followed by the request for a certificate. The originator answers with its certificate and issues a **SEC-Commit.req** primitive. This primitive indicates that the handshake is completed for the originator's side and that the originator now wants to switch into the newly negotiated connection state. The certificate is delivered to the peer side and the SEC-Commit is indicated. The WTLS layer of the peer sends back a confirmation to the originator. This concludes the full handshake for secure session setup.

#### WTLS datagram transfer

After setting up a secure connection between two peers, user data can be exchanged. This is done using the simple **SEC-Unitdata** primitive as shown in above figure. SEC-Unitdata has exactly the same function as T-DUnitdata on the WDP layer, namely it transfers a datagram between a sender and a receiver. This data transfer is still unreliable, but is now secure. This shows that WTLS can be easily plugged into the protocol stack on top of WDP.

### Wireless Transaction Protocol (WTP)

WTP has been designed to run on very thin clients, such as mobile phones. WTP offers several advantages to higher layers, including an improved reliability over datagram services, improved efficiency over connection-oriented services, and support for transaction-oriented services such as web browsing. WTP offers many features to the higher layers. The basis is formed from three **classes of transaction service**. Class 0 provides unreliable message transfer without any result message. Classes 1 and 2 provide reliable message transfer, class 1 without, class 2 with, exactly one reliable result message (the typical request/response case). WTP achieves reliability using **duplicate removal, retransmission, acknowledgements** and unique **transaction identifiers**.

WTP allows for **asynchronous transactions, abort of transactions, concatenation of messages**, and can **report success or failure** of reliable messages (e.g., a server cannot handle the request). The three service primitives offered by WTP are **TR-Invoke** to initiate a new transaction, **TR-Result** to send back the result of a previously initiated transaction, and **TR-Abort** to abort an existing transaction.

The PDUs exchanged between two WTP entities for normal transactions are the **invoke PDU**, **ack PDU**, and **result PDU**. A special feature of WTP is its ability to provide a **user acknowledgement** or, alternatively, an **automatic acknowledgement** by the WTP entity.

### WTP Class 0

Class 0 offers an unreliable transaction service without a result message. The transaction is stateless and cannot be aborted. The service is requested with the **TR-Invoke.req** primitive as shown below. Parameters are same as in WDP.

Additionally, with the **A** flag, the user of this service can determine, if the responder WTP entity should generate an **acknowledgement** or if a user acknowledgement should be used. The WTP layer will transmit the **user data (UD)** transparently to its destination. The class type **C** indicates here class 0. Finally, the transaction **handle H** provides a simple index to uniquely

identify the transaction and is an alias for the tuple (SA, SP, DA, DP), i.e., a socket pair, with only local significance. The WTP entity at the initiator sends an invoke PDU which the responder receives. The WTP entity at the responder then generates a **TR-Invoke.ind** primitive with the same parameters as on the initiator's side, except for H' which is now the local handle for the transaction on the responder's side. WTP class 0 augments the transaction service with a simple datagram like service for occasional use by higher layers.

## WTP Class 1

Class 1 offers a reliable transaction service but without a result message. Again, the initiator sends an invoke PDU after a **TR-Invoke.req** from a higher layer. This time, class equals '1', and no user acknowledgement has been selected as shown below.

The responder signals the incoming invoke PDU via the **TR-Invoke.ind** primitive to the higher layer and acknowledges automatically without user intervention. For the initiator the transaction ends with the reception of the acknowledgement. The responder keeps the transaction state for some time to be able to retransmit the acknowledgement if it receives the same invoke PDU again indicating a loss of the acknowledgement.

If a user of the WTP class 1 service on the initiator's side requests a user acknowledgement on the responder's side, the sequence diagram looks like the following figure.

Now the WTP entity on the responder's side does not send an acknowledgement automatically, but waits for the **TR-Invoke.res** service primitive from the user. This service primitive must have the appropriate local handle H' for identification of the right transaction. The WTP entity can now send the ack PDU. Typical uses for this transaction class are reliable push services.

## WTP Class 2

class 2 transaction service provides the classic reliable request/response transaction known from many client/server scenarios. Depending on user requirements, many different scenarios are possible for initiator/responder interaction. Three examples are presented below.

Example-1 scenario is shown below. A user on the initiator's side requests the service and the WTP entity sends the invoke PDU to the responder. The WTP entity on the responder's side indicates the request with the **TR-Invoke.ind** primitive to a user. The responder now waits for the processing of the request, the user on the responder's side can finally give the result UD\* to the WTP entity on the responder side using **TR-Result.req**. The **result PDU** can now be sent back to the initiator, which implicitly acknowledges the invoke PDU.

Example 1: WTP Class 2 Transaction, no user acknowledgement, no hold on

The initiator can indicate the successful transmission of the invoke message and the result with the two service primitives **TR-Invoke.cnf** and **TR-Result.ind**. A user may respond to this result with **TR-Result.res**. An acknowledgement PDU is then generated which finally triggers the **TR-Result.cnf** primitive on the responder's side. This example clearly shows the combination of

two reliable services (TR-Invoke and TR-Result) with an efficient data transmission/acknowledgement.

In example-2, the user on the responder's side now explicitly responds to the Invoke PDU using the **TR-Invoke.res** primitive, which triggers the **TR-Invoke.cnf** on the initiator's side via an **ack PDU**. The transmission of the result is also a confirmed service, as indicated by the next four service primitives. This service will likely be the most common in standard request/response scenarios as, e.g., distributed computing.

Example 2:- WTP Class 2 Transaction, user ack

**Example 3: WTP Class 2 Transaction, hold on, no user ack**



If the calculation of the result takes some time, the responder can put the initiator on “hold on” to prevent a retransmission of the invoke PDU as the initiator might assume packet loss if no result is sent back within a certain timeframe, which is shown above. After a time-out, the responder automatically generates an acknowledgement for the Invoke PDU. This shows the initiator that the responder is still alive and currently busy processing the request. After more time, the result PDU can be sent to the initiator.

## Wireless Session Protocol (WSP)

The wireless session protocol (WSP) has been designed to operate on top of the datagram service WDP or the transaction service WTP. WSP provides a shared state between a client and a server to optimize content transfer. WSP offers the following general features needed for content exchange between cooperating clients and servers:

- **Session management:** WSP introduces sessions that can be **established** from a client to a server and may be long lived. Sessions can also be **released** in an orderly manner. The capabilities of **suspending** and **resuming** a session are important to mobile applications.
- **Capability negotiation:** Clients and servers can agree upon a common level of protocol functionality during session establishment. Example parameters to negotiate are maximum client SDU size, maximum outstanding requests, protocol options, and server SDU size.
- **Content encoding:** WSP also defines the efficient binary encoding for the content it transfers. WSP offers content typing and composite objects, as explained for web browsing.

While WSP is a general-purpose session protocol, WAP has specified the **wireless session protocol/browsing (WSP/B)** which comprises protocols and services most suited for browsing-type applications, which offers the following features adapted to web browsing.

- **HTTP/1.1 functionality:** WSP/B supports the functions HTTP/1.1 offers, such as extensible request/reply methods, composite objects, and content type negotiation.
- **Exchange of session headers:** Client and server can exchange request/reply headers that remain constant over the lifetime of the session
- **pull data transfer:** Pulling data from a server is the traditional mechanism of the web. This is also supported by WSP/B using the request/response mechanism from HTTP/1.1. Additionally, WSP/B supports three push mechanisms for data transfer: a confirmed data push within an existing session context, a non-confirmed data push within an

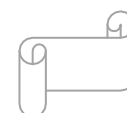

existing session context, and a non-confirmed data push without an existing session context.

- **Asynchronous requests:** Optionally, WSP/B supports a client that can send multiple requests to a server simultaneously. This improves efficiency for the requests and replies can now be coalesced into fewer messages.

## WSP/B over WTP

WSP/B uses the three service classes of WTP where, Class 0 is used for unconfirmed push, session resume, and session management. Confirmed push uses class 1, method invocation, session resume, and session management class 2.

The first example of session establishment of WSP/B using WTS class 2 transactions is shown below:

With the **S-Connect.req** primitive, a client can request a new session. Parameters are the **server address (SA)**, the **client address (CA)**, and the optional **client header (CH)** and **requested capabilities (RC)**. The session layer directly uses the addressing scheme of the layer below. WTP transfers the **connect PDU** to the server S-SAP where an **S-Connect.ind** primitive indicates a new session. Parameters are the same, but now the capabilities are mandatory. If the server accepts the new session it answers with an **S-Connect.res**, parameters are an optional **server header (SH)** with the same function as the client header and the **negotiated capabilities (NC)** needed for capability negotiation. WTP now transfers the **connreply PDU** back to the client; **S-Connect.cnf** confirms the session establishment and includes the **server header** (if present) and the **negotiated capabilities** from the server. WSP/B includes several procedures to refuse a session or to abort session establishment.

A very useful feature of WSP/B **session suspension** and **session resume** is shown below. A client can suspend the session because of several reasons. Session suspension will automatically abort all data transmission and freeze the current state of the session on the client and server side. A client suspends a session with **S-Suspend.req**, WTP transfers the **suspend PDU** to the server with a class 0 transaction, i.e., unconfirmed and unreliable. WSP/B will signal the suspension with **S-Suspend.ind** on the client and server side. The only parameter is the **reason R** for suspension. Reasons can be a user request or a suspension initiated by the service provider.

WSP/B session suspend/resume

Also shown above that, a client can later resume a suspended session with **S-Resume.req**. Parameters are **server address (SA)** and **client address (CA)**. Resuming a session is a confirmed operation. It is up to the server's operator how long this state is conserved.

Terminating a session is done by using the **S-Disconnect.req** service primitive as shown below.

WSP/B session termination

This primitive aborts all current method or push transactions used to transfer data. Disconnection is indicated on both sides using **S-Disconnect.ind**. The **reason R** for disconnection can be, e.g., network error, protocol error, peer request, congestion, and maximum SDU size exceeded.

The **S-MethodInvoke** primitive is used to request that an operation is executed by the server. The result, if any, is sent back using the **S-MethodResult** primitive as shown below:

#### WSP/B method invoke

A client requests an operation with **S-MethodInvoke.req**. Parameters are the **client transaction identifier CTID** to distinguish between pending transactions, the **method M** identifying the requested operation at the server, and the **request URI** (Uniform Resource Identifier **RU**). The WTP class 2 transaction service now transports the **method PDU** to the server. A method PDU can be either a get PDU or a post PDU.

On the server's side, **S-MethodInvoke.ind** indicates the request. In this case, a **server transaction identifier STID** distinguishes between pending transactions. The server confirms the request, so WSP/B does not generate a new PDU but relies on the lower WTP layer. Similarly, the result of the request is sent back to the client using the **SMethodResult** primitive. Additional parameters are now the **status (S)**, the **response header (RH)**, and the **response body (RB)**.

WSP does not introduce PDUs or service primitives just for the sake of symmetric and aesthetic protocol architecture. The following figure shows how WSP (thus also WSP/B) uses the underlying WTP services for its purposes. The **S-MethodInvoke.req** primitive triggers the **TR-Invoke.req** primitive, the parameters of the WSP layer are the user data of the WTP layer. The **invoke PDU** of the WTP layer carries the **method PDU** of the WSP layer inside.

For the confirmation of its service primitives the WSP layer has none of its own PDUs but uses the **acknowledgement PDUs** of the WTP layer. **S-MethodInvoke.res** triggers **TR-Invoke.res**, the **ack PDU** is transferred to the initiator, here **TR-Invoke.cnf** confirms the invoke service and triggers the **S-MethodInvoke.cnf** primitive which confirms the method invocation service. This mingling of layers saves a lot of redundant data flow but still allows a separation of the tasks between the two layers.

With the help of push primitives, a server can push data towards a client if allowed. The simplest push mechanism is the non-confirmed push as shown below.

The server sends unsolicited data with the **S-Push.req** primitive to the client. Parameters are the **push header (PH)** and the **push body (PB)** again, these are the header and the body known from HTTP. The unreliable, unconfirmed WTP class 0 transaction service transfers the **push PDU** to the client where **S-Push.ind** indicates the push event.

A more reliable push service offers the **S-ConfirmedPush** primitive as shown below.

Here the server has to determine the push using a **server push identifier (SPID)**. This helps to distinguish between different pending pushes. The reliable WTP class 1 transaction service is now used to transfer the **confpush PDU** to the client. On the client's side a **client push identifier (CPID)** is used to distinguish between different pending pushes.

### WSP/B as connectionless session service

WSP/B could be run on top of the connectionless, unreliable WDP service. As an alternative to WDP, WTLS can always be used if security is required. The service primitives are directly mapped onto each other. The following figure shows the three service primitives available for connectionless session service: **S-Unit-MethodInvoke.req** to request an operation on a server, **S-Unit-MethodResult.req** to return results to a client, and **S-Unit-Push.req** to push data onto a client. Transfer of the PDUs (**method**, **reply** and **push**) is done with the help of the standard unreliable datagram transfer service of WDP.

Besides the server address (**SA**), the client address (**CA**), the method (**M**), and the request URI (**RU**), the user of the **S-Unit-MethodInvoke.req** primitive can determine a transaction identifier (**TID**) to distinguish between different transactions on the user level. TID is communicated transparently from service user to service user.

The function of the **S-Unit-MethodResult** primitive remains the same as explained above: the **status (S)**, **response header (RH)**, and **response body (RB)** represent the result of the operation. The **S-Unit-Push** primitive has the parameters **client address (CA)**, **server address (SA)**, **push identifier (PID)**, **push header (PH)**, and **push body (PB)**.

## Wireless application environment (WAE)

The main idea behind the wireless application environment (WAE) is to create a general-purpose application environment based mainly on existing technologies and philosophies of the world wide web. One global goal of the WAE is to minimize over-the-air traffic and resource consumption on the handheld device, which is reflected in the logical model shown below:

A **client** issues an encoded request for an operation on a remote server. Encoding is necessary to minimize data sent over the air and to save resources on the handheld device. Decoders in a **gateway** now translate this encoded request into a standard request as understood by the **origin servers**. This could be a request to get a web page to set up a call. The gateway transfers this request to the appropriate origin server as if it came from a standard client. Origin servers could be standard web servers running HTTP and generating content using scripts, providing pages using a database, or applying any other (proprietary) technology.

The origin servers will respond to the request. The gateway now encodes the response and its content (if there is any) and transfers the encoded response with the content to the client. The WAE logical model not only includes this standard request/response scheme, but it also includes push services. Then an origin server pushes content to the gateway. The gateway encodes the pushed content and transmits the encoded push content to the client. Several user agents can reside within a client. User agents include such items as: browsers, phonebooks, message editors etc. WAE does not specify the number of user agents or their functionality, but assumes a basic **WML user agent** that supports WML, WMLscript, or both (i.e., a 'WML browser'). However, one more user agent has been specified with its fundamental services, the **WTA user agent**. This user agent handles access to, and interaction with, mobile telephone features (such as call control). As over time many vendor dependent user agents may develop, the standard defines a **user agent profile (UAProf)**, which describes the capabilities of a user agent.

## Wireless Markup Language (WML)

The **wireless markup language (WML)** is based on the standard HTML known from the www and on HDML. WML is specified as an XML document type. Several constraints of wireless handheld devices had to be taken into account, when designing WML.

WML follows a deck and card metaphor. A WML document is made up of multiple **cards**. Cards can be grouped together into a **deck**. A WML deck is similar to an HTML page, in that it is identified by a URL and is the unit of content transmission. A user navigates with the WML browser through a series of WML cards, reviews the contents, enters requested data, makes choices etc. The WML browser fetches decks as required from origin servers. Either these decks can be static files on the server or they can be dynamically generated. WML describes the intent of interaction in an abstract manner. The user agent on a handheld device has to decide how to



best present all elements of a card. This presentation depends much on the capabilities of the device.

WML includes several basic features:

- ❖ **Text and images:** WML gives, as do other mark-up languages, hints how text and images can be presented to a user
- ❖ **User interaction:** WML supports different elements for user input. Examples are: text entry controls for text or password entry, option selections or controls for task invocation. **Navigation:** As with HTML browsers, WML offers a history mechanism with navigation through the browsing history, hyperlinks and other intercard navigation elements.
- ❖ **Context management:** WML allows for saving the state between different decks without server interaction, i.e., variable state can last longer than a single deck, and so state can be shared across different decks.

## WML script

WMLScript complements to WML and provides a general scripting capability in the WAP architecture. While all WML content is static (after loading on the client), WMLScript offers several capabilities not supported by WML:

- ❖ **Validity check of user input:** before user input is sent to a server, WMLScript can check the validity and save bandwidth and latency in case of an error.
- ❖ **Access to device facilities:** WMLScript offers functions to access hardware components and software functions of the device.
- ❖ **Local user interaction:** Without introducing round-trip delays, WMLScript can directly and locally interact with a user, show messages or prompt for input.
- ❖ **Extensions to the device software:** With the help of WMLScript a device can be configured and new functionality can be added even after deployment.

WMLScript is based on JavaScript, but adapted to the wireless environment. WMLScript is event-based, i.e., a script may be invoked in response to certain user or environment events. WMLScript also has full access to the state model of WML, i.e., WMLScript can set and read WML variables. WMLScript provides many features known from standard programming languages such as functions, expressions, or `while`, `if`, `for`, `return` etc. The WAP Forum has specified several **standard libraries** for WMLScript (WAP Forum, 2000i). These libraries provide access to the core functionality of a WAP client so they, must be available in the client's scripting environment. The six libraries defined are **Lang, Float, String, URL, WML browser** and **Dialogs**.

## BLUETOOTH

"Bluetooth" was the nickname of Harald Blåtland II, king of Denmark from 940 to 981, who united all of Denmark and part of Norway under his rule. **Bluetooth** is a proprietary open wireless technology standard for exchanging data over short distances (using short wavelength radio transmissions in the ISM band from 2400-2480 MHz) from fixed and mobile devices, creating personal area networks (PANs) with high levels of security. The Bluetooth technology aims at so-called **ad-hoc piconets**, which are local area networks with a very limited coverage and without the need for an infrastructure.

### Bluetooth Features

- Bluetooth is wireless and automatic. You don't have to keep track of cables, connectors, and connections, and you don't need to do anything special to initiate communications. Devices find each other automatically and start conversing without user input, except where authentication is required; for example, users must log in to use their email accounts.
- Bluetooth is inexpensive. Market analysts peg the cost to incorporate Bluetooth technology into a PDA, cell phone, or other product at a minimum cost.
- The ISM band that Bluetooth uses is regulated, but unlicensed. Governments have converged on a single standard, so it's possible to use the same devices virtually wherever you travel, and you don't need to obtain legal permission in advance to begin using the technology.
- Bluetooth handles both data and voice. Its ability to handle both kinds of transmissions simultaneously makes possible such innovations as a mobile hands-free headset for voice with applications that print to fax, and that synchronize the address books on your PDA, your laptop, and your cell phone.
- Signals are omni-directional and can pass through walls and briefcases. Communicating devices don't need to be aligned and don't need an unobstructed line of sight like infrared.
- Bluetooth uses *frequency hopping*. Its *spread spectrum* approach greatly reduces the risk that communications will be intercepted.

### Bluetooth Applications

- File transfer.
- Ad-hoc networking: Communicating devices can spontaneously form a community of networks that persists only as long as it's needed

- Device synchronization: Seamless connectivity among PDAs, computers, and mobile phones allows applications to update information on multiple devices automatically when data on any one device changes.
- Peripheral connectivity.
- Car kits: Hands-free packages enable users to access phones and other devices without taking their hands off the steering wheel
- Mobile payments: Your Bluetooth-enabled phone can communicate with a Bluetooth-enabled vending machine to buy a can of Diet Pepsi, and put the charge on your phone bill.

The 802.11b protocol is designed to connect relatively large devices with lots of power and speed, such as desktops and laptops, where devices communicate at up to 11 Mbit/sec, at greater distances (up to 300 feet, or 100 meters). By contrast, Bluetooth is designed to connect small devices like PDAs, mobile phones, and peripherals at slower speeds (1 Mbit/sec), within a shorter range (30 feet, or 10 meters), which reduces power requirements. Another major difference is that 802.11b wasn't designed for voice communications, while any Bluetooth connection can support both data and voice communications.

## ***User scenarios***

Many different user scenarios can be imagined for wireless piconets or WPANs:

**Connection of peripheral devices:** Today, most devices are connected to a desktop computer via wires (e.g., keyboard, mouse, joystick, headset, speakers). This type of connection has several disadvantages: each device has its own type of cable, different plugs are needed, wires block office space. In a wireless network, no wires are needed for data transmission. However, batteries now have to replace the power supply, as the wires not only transfer data but also supply the peripheral devices with power.

**Support of ad-hoc networking:** Imagine several people coming together, discussing issues, exchanging data (schedules, sales figures etc.). For instance, students might join a lecture, with the teacher distributing data to their personal digital assistants (PDAs). Wireless networks can support this type of interaction; small devices might not have WLAN adapters following the IEEE 802.11 standard, but cheaper Bluetooth chips built in.

**Bridging of networks:** Using wireless piconets, a mobile phone can be connected to a PDA or laptop in a simple way. Mobile phones will not have full WLAN adapters built in, but could have a Bluetooth chip. The mobile phone can then act as a bridge between the local piconet and, e.g., the global GSM network.

## Networking in Bluetooth

Bluetooth operates on 79 channels in the 2.4 GHz band with 1 MHz carrier spacing. Each device performs frequency hopping with 1,600 hops/s in a pseudo random fashion. A piconet is a collection of Bluetooth devices which are synchronized to the same hopping sequence. One device in the piconet can act as **master** (M), all other devices connected to the master must act as **slaves** (S). The master determines the hopping pattern in the piconet and the slaves have to synchronize to this pattern. Each piconet has a unique hopping pattern. If a device wants to participate it has to synchronize to this. A typical piconet is shown below:

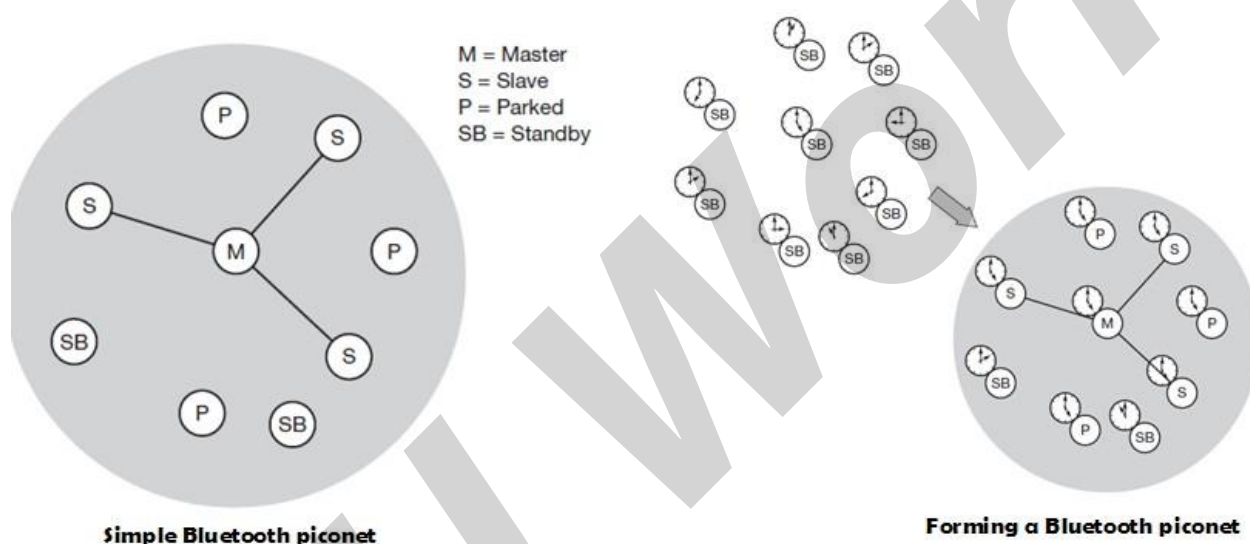

Parked devices (P) can not actively participate in the piconet (i.e., they do not have a connection), but are known and can be reactivated within some milliseconds. Devices in stand-by (SB) do not participate in the piconet. Each piconet has exactly one master and up to seven simultaneous slaves. More than 200 devices can be parked. The first step in forming a piconet involves a master sending its clock and device ID. All the Bluetooth devices have the same capability to become a master or a slave and two or three devices are sufficient to form a piconet. The unit establishing the piconet automatically becomes the master, all other devices will be slaves. The hopping pattern is determined by the device ID, a 48-bit worldwide unique identifier.

The phase in the hopping pattern is determined by the master's clock. After adjusting the internal clock according to the master a device may participate in the piconet. All active devices are assigned a 3-bit **active member address** (AMA). All parked devices use an 8-bit **parked member address** (PMA). Devices in stand-by do not need an address.

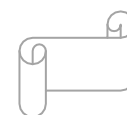

A device in one piconet can communicate to another device in another piconet, forming a **scatternet**. A master in one piconet may be a slave in another piconet. Both piconets use a different hopping sequence, always determined by the master of the piconet. Bluetooth applies **FH-CDMA** for separation of piconets. A collision occurs if two or more piconets use the same

carrier frequency at the same time. This will probably happen as the hopping sequences are not coordinated. If a device wants to participate in more than one piconet, it has to synchronize to the hopping sequence of the piconet it wants to take part in. If a device acts as slave in one piconet, it simply starts to synchronize with the hopping sequence of the piconet it wants to join. After synchronization, it acts as a slave in this piconet and no longer participates in its former piconet. To enable synchronization, a slave has to know the identity of the master that determines the hopping sequence of a piconet. Before

leaving one piconet, a slave informs the current master that it will be unavailable for a certain amount of time. The remaining devices in the piconet continue to communicate as usual.

### *Bluetooth Protocol Stack*

The Bluetooth protocol stack can be divided into a **core specification**, which describes the protocols from physical layer to the data link control together with management functions, and **profile specifications** describing many protocols and functions needed to adapt the wireless Bluetooth technology to legacy and new applications.

A high-level view of the architecture is shown. The responsibilities of the layers in this stack are as follows:

- ❖ *The radio layer* is the physical wireless connection. To avoid interference with other devices that communicate in the ISM band, the modulation is based on fast frequency hopping. Bluetooth divides the 2.4 GHz frequency band into 79 channels 1 MHz apart (from 2.402 to 2.480 GHz), and uses this spread spectrum to hop from one channel to another, up to 1600

times a second. The standard wavelength range is 10 cm to 10 m, and can be extended to 100 m by increasing transmission power.

### Bluetooth Protocol Stack

- ❖ *The baseband layer* is responsible for controlling and sending data packets over the radio link. It provides transmission channels for both data and voice. The baseband layer maintains Synchronous Connection-Oriented (SCO) links for voice and Asynchronous Connectionless (ACL) links for data. SCO packets are never retransmitted but ACL packets are, to ensure data integrity. SCO links are point-to-point symmetric connections, where time slots are reserved to guarantee timely transmission. A slave device is allowed to respond during the time slot immediately following an SCO transmission from the master. A master can support up to three SCO links to a single slave or to multiple slaves, and a single slave can support up to two SCO links to different slaves. Data transmissions on ACL links, on the other hand, are established on a per-slot basis (using slots not reserved for SCO links). ACL links support point-to-multipoint transmissions. After an ACL transmission from the master, only a slave addressed specifically may respond during the next time slot; if no device is addressed, the message is treated as a broadcast.
- ❖ *The Link Manager Protocol (LMP)* uses the links set up by the baseband to establish connections and manage piconets. Responsibilities of the LMP also include authentication and security services, and monitoring of service quality.
- ❖ *The Host Controller Interface (HCI)* is the dividing line between software and hardware. The L2CAP and layers above it are currently implemented in software, and the LMP and lower layers are in hardware. The HCI is the driver interface for the physical bus that connects these two components. The HCI may not be required. The L2CAP may be accessed directly

by the application, or through certain support protocols provided to ease the burden on application programmers.

- ❖ *The Logical Link Control and Adaptation Protocol (L2CAP)* receives application data and adapts it to the Bluetooth format. Quality of Service (QoS) parameters are exchanged at this layer.

### *Link Manager Protocol*

The link manager protocol (LMP) manages various aspects of the radio link between a master and a slave and the current parameter setting of the devices. LMP enhances baseband functionality, but higher layers can still directly access the baseband. The following groups of functions are covered by the LMP:

- ❖ **Authentication, pairing, and encryption:** Although basic authentication is handled in the baseband, LMP has to control the exchange of random numbers and signed responses. LMP is not directly involved in the encryption process, but sets the encryption mode (no encryption, point-to-point, or broadcast), key size, and random speed.
- ❖ **Synchronization:** Precise synchronization is of major importance within a Bluetooth network. The clock offset is updated each time a packet is received from the master.
- ❖ **Capability negotiation:** Not only the version of the LMP can be exchanged but also information about the supported features. Not all Bluetooth devices will support all features that are described in the standard, so devices have to agree the usage of, e.g., multi-slot packets, encryption, SCO links, voice encoding, park/sniff/hold mode, HV2/HV3 packets etc.
- ❖ **Quality of service negotiation:** Different parameters control the QoS of a Bluetooth device at these lower layers. The poll interval, i.e., the maximum time between transmissions from a master to a particular slave, controls the latency and transfer capacity. A master can also limit the number of slots available for slaves' answers to increase its own bandwidth.
- ❖ **Power control:** A Bluetooth device can measure the received signal strength. Depending on this signal level the device can direct the sender of the measured signal to increase or decrease its transmit power.
- ❖ **Link supervision:** LMP has to control the activity of a link, it may set up new SCO links, or it may declare the failure of a link.
- ❖ **State and transmission mode change:** Devices might switch the master/slave role, detach themselves from a connection, or change the operating mode

Bluetooth defines several low-power states for a device. The following figure shows the major states of a Bluetooth device and typical transitions. Every device, which is currently not participating in a piconet (and not switched off), is in **standby** mode. This is a low-power mode where only the native clock is running. The next step towards the **inquiry** mode can happen in two different ways. Either a device wants to establish a piconet or a device just wants to listen to see if something is going on.

#### Major baseband states of a Bluetooth device

- *A device wants to establish a piconet:* A user of the device wants to scan for other devices in the radio range. The device starts the inquiry procedure by sending an inquiry access code (IAC) that is common to all Bluetooth devices. The IAC is broadcast over 32 so-called wake-up carriers in turn.
- *Devices in standby that listen periodically:* Devices in standby may enter the inquiry mode periodically to search for IAC messages on the wake-up carriers. As soon as a device detects an inquiry it returns a packet containing its device address and timing information required by the master to initiate a connection. From that moment on, the device acts as slave.

If the inquiry was successful, a device enters the page mode. The inquiry phase is not coordinated, so it may take a while before the inquiry is successful. After a while, a Bluetooth device sees all the devices in its radio range.



During the **page** state two different roles are defined. After finding all required devices the master is able to set up connections to each device, i.e., setting up a piconet. As soon as a device synchronizes to the hopping pattern of the piconet it also enters the connection state. The connection state comprises the active state and the low power states: **park**, **sniff**, and **hold**. In the **active** state the slave participates in the piconet by listening, transmitting, and receiving. ACL and SCO links can be used. A master periodically synchronizes with all slaves. All devices being active must have the 3-bit **active member address** (AMA). To save battery power, a Bluetooth device can go into one of three low power states:

- **Sniff state:** The sniff state has the highest power consumption of the low power states. Here, the device listens to the piconet at a reduced rate (not on every other slot as is the case in the active state). The interval for listening into the medium can be programmed and is application dependent. The master designates a reduced number of slots for transmission to slaves in sniff state. However, the device keeps its AMA.
- **Hold state:** The device does not release its AMA but stops ACL transmission. A slave may still exchange SCO packets. If there is no activity in the piconet, the slave may either reduce power consumption or participate in another piconet.
- **Park state:** In this state the device has the lowest duty cycle and the lowest power consumption. The device releases its AMA and receives a parked member address (PMA). The device is still a member of the piconet, but gives room for another device to become active (AMA is only 3 bit, PMA 8 bit). Parked devices are still FH synchronized and wake up at certain beacon intervals for re-synchronization. All PDUs sent to parked slaves are broadcast.

## **L2CAP**

The logical link control and adaptation protocol (L2CAP) is a data link control protocol on top of the baseband layer offering logical channels between Bluetooth devices with QoS properties. L2CAP is available for ACLs only.

L2CAP provides three different types of logical channels that are transported via the ACL between master and slave:

- ❖ **Connectionless:** These unidirectional channels are typically used for broadcasts from a master to its slave(s).
- ❖ **Connection-oriented:** Each channel of this type is bi-directional and supports QoS flow specifications for each direction. These flow specs follow RFC 1363 and define average/peak data rate, maximum burst size, latency, and jitter.

- ❖ Signaling: This third type of logical channel is used to exchanging signaling messages between L2CAP entities.

Each channel can be identified by its **channel identifier (CID)**. Signaling channels always use a CID value of 1, a CID value of 2 is reserved for connectionless channels. For connection-oriented channels a unique CID ( $\geq 64$ ) is dynamically assigned at each end of the channel to identify the connection.

The following figure shows the three packet types belonging to the three logical channel types.

The **length** field indicates the length of the payload (plus PSM for connectionless PDUs). The **CID** has the multiplexing/demultiplexing function. For connectionless PDUs a **protocol/service multiplexor (PSM)** field is needed to identify the higher layer recipient for the payload. For connection-oriented PDUs the CID already fulfills this function. Several PSM values have been defined, e.g., 1 (SDP), 3 (RFCOMM), 5 (TCS-BIN). Values above 4096 can be assigned dynamically. The payload of the signaling PDU contains one or more **commands**. Each command has its own **code** (e.g., for command reject, connection request, disconnection response etc.) and an **ID** that matches a request with its reply. The **length** field indicates the length of the **data** field for this command.

Besides protocol multiplexing, flow specification, and group management, the L2CAP layer also provides segmentation and reassembly functions. Depending on the baseband capabilities, large packets have to be chopped into smaller segments.

## Security

The main security features offered by Bluetooth include a challenge response routine for authentication, a stream cipher for encryption, and a session key generation. Each connection may require a one-way, two-way, or no authentication using the challenge-response routine. The security algorithms use the public identity of a device, a secret private user key, and an internally generated random key as input parameters. For each transaction, a new random number is generated on the Bluetooth chip. Key management is left to higher layer software. The following figure shows several steps in the security architecture of Bluetooth.

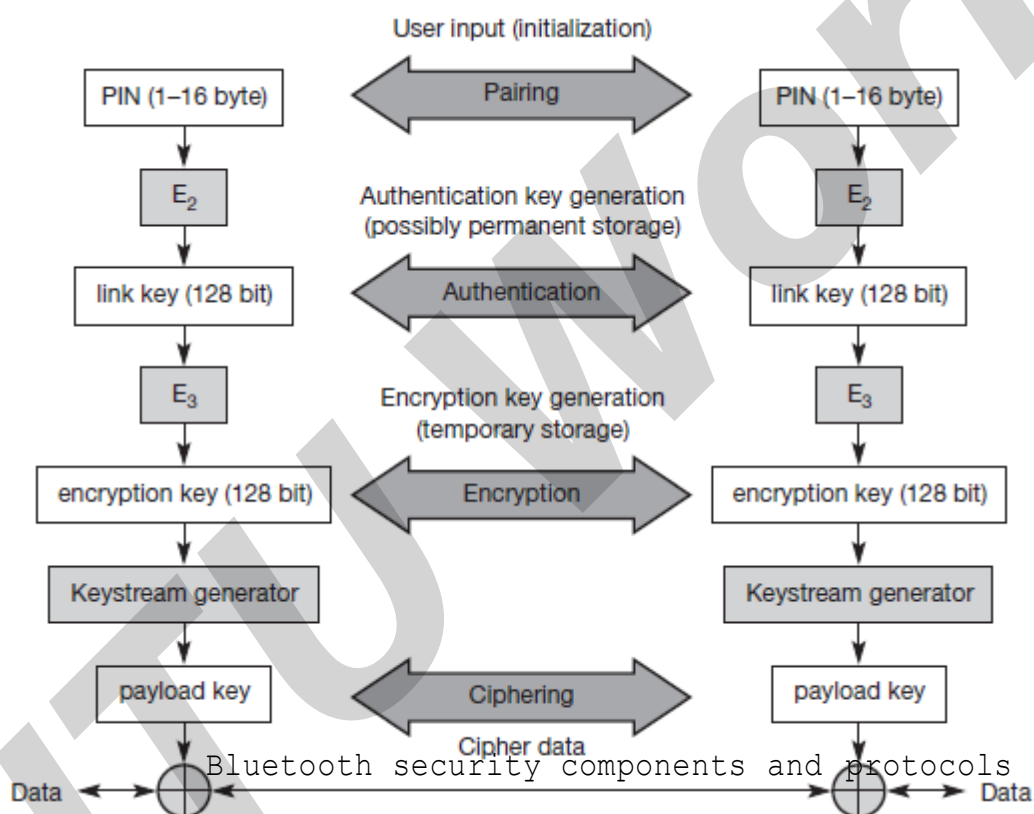

The first step, called **pairing**, is necessary if two Bluetooth devices have never met before. To set up trust between the two devices a user can enter a secret PIN into both devices. This PIN can have a length of up to 16 byte. Based on the PIN, the device address, and random numbers, several keys can be computed which can be used as link key for **authentication**. The authentication is a challenge-response process based on the link key, a random number generated by a verifier (the device that requests authentication), and the device address of the claimant (the device that is authenticated).

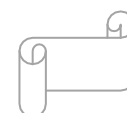

Based on the link key, and again a random number an encryption key is generated during the **encryption** stage of the security architecture. This key has a maximum size of 128 bits and can be individually generated for each transmission. Based on the encryption key, the device address and the current clock a payload key is generated for ciphering user data. The payload key is a stream of pseudo-random bits. The **ciphering** process is a simple XOR of the user data and the payload key.

All Bluetooth-enabled devices must implement the Generic Access Profile, which contains all the Bluetooth protocols and possible devices. This profile defines a security model that includes three security modes:

- *Mode 1* is an insecure mode of operation. No security procedures are initiated.
- *Mode 2* is known as *service-level enforced security*. When devices operate in this mode, no security procedures are initiated before the channel is established. This mode enables applications to have different access policies and run them in parallel.
- *Mode 3* is known as *link-level enforced security*. In this mode, security procedures are initiated before link setup is complete.

Though Bluetooth offers a better security than WEP in 802.11, it has several limitations. The PIN's are often fixed and some keys are permanently stored on the devices. The quality of the random number generators has not been specified.

### **SDP**

To find new services available in the radio proximity, Bluetooth defined the **service discovery protocol (SDP)**. SDP defines only the discovery of services, not their usage. Discovered services can be cached and gradual discovery is possible. All the information an SDP server has about a service is contained in a **service record**. This consists of a list of service attributes and is identified by a 32-bit service record handle.

A service attribute consists of an attribute ID and an attribute value. The 16-bit attribute ID distinguishes each service attribute from other service attributes within a service record. The attribute ID also identifies the semantics of the associated attribute value. The attribute value can be an integer, a UUID (universally unique identifier), a string, a Boolean, a URL (uniform resource locator) etc.

## Bluetooth Profiles

Bluetooth profiles are intended to ensure interoperability among Bluetooth-enabled devices and applications from different manufacturers and vendors. A profile defines the roles and capabilities for specific types of applications. **Profiles** represent default solutions for a certain usage model. They use a selection of protocols and parameter set to form a basis for interoperability. Protocols can be seen as horizontal layers while profiles are vertical slices as shown below:

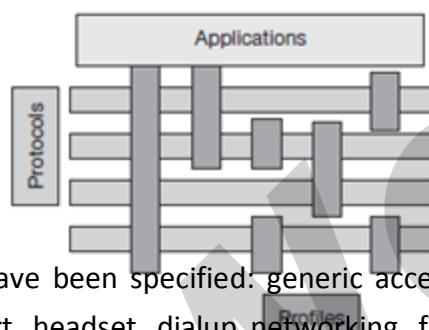

The following **basic profiles** have been specified: generic access, service discovery, cordless telephony, intercom, serial port, headset, dialup networking, fax, LAN access, generic object exchange, object push, file transfer, and synchronization. **Additional profiles** are: advanced audio distribution, PAN, audio video remote control, basic printing, basic imaging, extended service discovery, generic audio video distribution, hands-free, and hardcopy cable replacement. Some of the profiles are given below:

- The *Generic Access Profile* defines connection procedures, device discovery, and link management. It also defines procedures related to use of different security models and common format requirements for parameters accessible on the user interface level. At a minimum all Bluetooth devices must support this profile.
- The *Service Discovery Application and Profile* defines the features and procedures for an application in a Bluetooth device to discover services registered in other Bluetooth devices, and retrieves information related to the services.
- The *Serial Port Profile* defines the requirements for Bluetooth devices that need to set up connections that emulate serial cables and use the RFCOMM protocol.
- The *LAN Access Profile* defines how Bluetooth devices can access the services of a LAN using PPP, and shows how PPP mechanisms can be used to form a network consisting of Bluetooth devices.

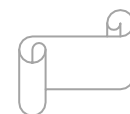

- The *Synchronization Profile* defines the application requirements for Bluetooth devices that need to synchronize data on two or more devices.

## Java 2 Micro Edition (J2ME)

Sun Microsystems defines J2ME as "a highly optimized Java run-time environment targeting a wide range of consumer products, including pagers, cellular phones, screen-phones, digital set-top boxes and car navigation systems." J2ME brings the cross-platform functionality of the Java language to smaller devices, allowing mobile wireless devices to share applications. Java 2 Micro Edition maintains the qualities that Java technology has become known for:

- built-in consistency across products in terms of running anywhere, anytime, on any device
- the power of a high-level object-oriented programming language with a large developer base;
- portability of code;
- safe network delivery; and
- upward scalability with J2SE and J2EE

While connected consumer devices such as cell phones, pagers, personal organizers and set-top boxes have many things in common, they are also diverse in form, function and features. Information appliances tend to be special-purpose, limited-function devices. To address this diversity, an essential requirement for J2ME is not only small size but also modularity and customizability. The J2ME architecture is modular and scalable so that it can support the kinds of flexible deployment demanded by the consumer and embedded markets. To support this kind of customizability and extensibility, two essential concepts are defined by J2ME:

- ❖ *Configuration*. A J2ME configuration defines a minimum platform for a "horizontal" category or grouping of devices, each with similar requirements on total memory budget and processing power. A configuration defines the Java language and virtual machine features and minimum class libraries that a device manufacturer or a content provider can expect to be available on all devices of the same category.
- ❖ *Profile*. A J2ME profile is layered on top of (and thus extends) a configuration. A profile addresses the specific demands of a certain "vertical" market segment or device family. The main goal of a profile is to guarantee interoperability within a certain vertical device family or domain by defining a standard Java platform for that market. Profiles typically include

class libraries that are far more domain-specific than the class libraries provided in a configuration.

J2ME software layer stack

## Configurations

A configuration is a subset of profile. A configuration defines a Java platform for a “horizontal” category or grouping of devices with similar requirements on total memory budget and other hardware capabilities. More specifically, a configuration:

- specifies the Java programming language features supported,
- specifies the Java virtual machine features supported,
- specifies the basic Java libraries and APIs supported.

To avoid fragmentation, there will be a very limited number of J2ME configurations. Currently, the goal is to define two standard J2ME configurations:

- **Connected, Limited Device Configuration (CLDC).** The market consisting of personal, mobile, connected information devices is served by the CLDC. This configuration includes some new classes, not drawn from the J2SE APIs, designed specifically to fit the needs of small-footprint devices. It is used specifically with the KVM for 16-bit or 32-bit devices with limited amounts of memory. This is the configuration (and the virtual machine) used for developing small J2ME applications.
- **Connected Device Configuration (CDC).** The market consisting of shared, fixed, connected information devices is served by the Connected Device Configuration (CDC). To ensure upward compatibility between configurations, the CDC shall be a superset of the CLDC. This

is used with the C virtual machine (CVM) and is used for 32-bit architectures requiring more than 2 MB of memory.

JNTU World

J2ME Universe



## Profiles

The J2ME framework provides the concept of a *profile* to make it possible to define Java platforms for specific vertical markets. Profiles can serve two distinct portability requirements:

- A profile provides a complete toolkit for implementing applications for a particular kind of device, such as a pager, set-top box, cell phone, washing machine, or interactive electronic toy.
- A profile may also be created to support a significant, coherent group of applications that might be hosted on several categories of devices.

Foundation profile contains APIs of J2SE without GUIs. PersonalProfile is profile for embedded devices. Two profiles have been defined for J2ME and are built on CLDC: KJava and Mobile Information Device Profile (MIDP). These profiles are geared toward smaller devices.

MIDP 3.0 is the latest profile version, which is a profile for special-featured phones and handheld devices. It provides improved UI's, UI extensibility and interoperability between the devices. It supports multiple network interfaces in a device, IPv6, large display devices and high performance games. Development tools are used to develop MIDP applications. MIDP applications are composed of two parts:

- JAR File – Contains all of the classes and resources used by the application
- JAD File – Application descriptor, describes how to run the MIDP application

	<b>Source Package</b>	<b>Sets of Java class libraries</b>
1	<i>Java.lang</i>	standard java types and classes for String, Integer, Math, Thread, Security and Exception
2	<i>Java.io</i>	Standard java types and classes for input and output streams
3	<i>Java.util</i>	A set of classes such as Timers, Calenders, Dates, Hashtables, Vectors and others
4	<i>Javax.microedition.rms</i>	A record management system (RMS) API to retrieve and save data and limited querying capability
5	<i>Javax.microedition.pim</i>	Personal information management API (optional), access the device's address book
6	<i>Javax.microedition.pki</i>	Secure connections authenticate API's

MIDP source packages and sets of Java class libraries

## **K Virtual Machine**

The KVM is a compact, portable Java virtual machine specifically designed from the ground up for small, resource-constrained devices. The high-level design goal for the KVM was to create the smallest possible “complete” Java virtual machine that would maintain all the central aspects of the Java programming language, but would run in a resource-constrained device with only a few hundred kilobytes total memory budget. More specifically, the KVM was designed to be:

- small, with a static memory footprint of the virtual machine core in the range of 40 kilobytes to 80 kilobytes (depending on compilation options and the target platform,)
- clean, well-commented, and highly portable,
- modular and customizable, as “complete” and “fast” as possible without sacrificing the other design goals.

The “K” in KVM stands for “kilo.” It was so named because its memory budget is measured in kilobytes (whereas desktop systems are measured in megabytes). KVM is suitable for 16/32-bit RISC/CISC microprocessors with a total memory budget of no more than a few hundred kilobytes (potentially less than 128 kilobytes). This typically applies to digital cellular phones, pagers, personal organizers, and small retail payment terminals.

JNTU World