



# Modelling of Parallel Hybrid Transmission for Electric Vehicles

Voruganti Bharath Kumar<sup>1</sup>, P Kamalakar<sup>2</sup>, Ashish Kumar Singh<sup>3</sup>, Waseem Ahamed<sup>4</sup>

<sup>1</sup>Assistant Professor in EEE Department, St. Martin's Engineering College (Autonomous), Secunderabad-500100, INDIA

<sup>2</sup>Assistant Professor in EEE Department, Malla Reddy Engineering College (Autonomous), Maisammaguda, Secunderabad 500100, INDIA

<sup>3</sup>Assistant Professor in Mechanical Department, Hyderabad Institute of Technology and Management, (Autonomous), Medchal - 501401, INDIA

<sup>4</sup>Assistant Professor in Mechanical Department, B V Raju Institute of Technology, Narsapur -502313, INDIA

**Abstract**— The electric vehicle has been researched as an alternate mode of transportation due to rising environmental concerns and ever-stricter emissions laws. However, due to its limited range and lengthy charging times, the electric vehicle has not yet proven to be an acceptable answer for the automobile consumer. One approach of utilising the great efficiency and absence of emissions of an electric vehicle while maintaining the range and convenient refuelling periods of a normal gasoline-powered vehicle is to add an internal combustion engine to increase the range of the electric vehicle. The term that describes this type of vehicle is a hybrid electric vehicle. A hybrid vehicle is one that is powered by at least two different sources of energy. A vehicle with an electric motor as one of its power sources is referred to as a "hybrid-electric vehicle." The other source of motive power can be a variety of technologies, but the most typical is a gasoline or diesel-fueled internal combustion engine. This paper presents Modelling of Parallel Hybrid Transmission for Electric Vehicles

**Keywords**— *hybrid electric vehicle, Battery, IC Engine, Power Converter, Motor.*

## I. INTRODUCTION

In the short to medium term, hybrid electric vehicles (HEVs) with an engine and one or more electric machines are commonly recognised as the most promising alternative for clean transportation [1]. Various automakers are now working on hybrid electric vehicles. These vehicles are currently being sold as a method to increase the efficiency of our transportation system while also reducing our reliance on and consumption of foreign petroleum [2],[3],[4]. Recent REV research efforts have been focused on building energy-efficient and cost-effective propulsion systems. The two most often accepted classifications for hybrid modes are series and parallel. While the series design is good for high energy demands, the parallel hybrid is better for high road power demands [5],[6].

## II. PARALLEL HYBRID TRANSMISSION

The parallel HEV allows both the internal combustion engine (ICE) and the electric motor (EM) to send power to the wheels. Because both the ICE and the EM are connected to the drive shaft of the wheels through two clutches, the propulsion power can come from either the ICE or the EM. When the ICE's output is greater than that required to move the wheels, the EM can be employed as a generator to charge the battery via regenerative braking or by absorbing power from the ICE.

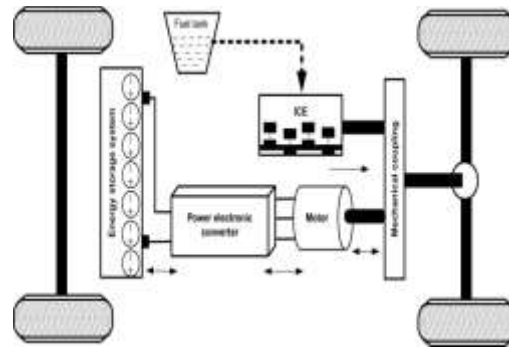

Fig. 1. Schematic diagram of Parallel Hybrid Transmission

## II. POWER FLOW CONTROL IN PARALLEL HYBRID

There are four modes of operation for the parallel hybrid system. These are the four modes of operation..

### A. Mode-1

During start up or full throttle acceleration (Figure 2a); both the ICE and the EM share the required power to propel the vehicle. Typically, the relative distribution between the ICE and electric motor is 80-20%.

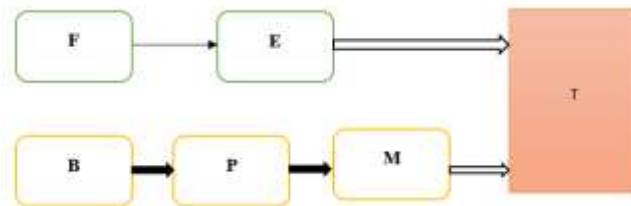

Fig. 2a start up

### B. Mode-II

During normal driving (Figure 2b), the required traction power is supplied by the ICE only and the EM remains in off mode.

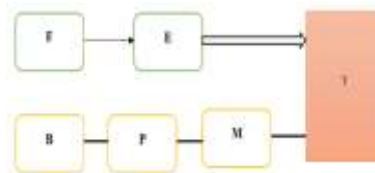

Fig. 2b normal driving

### C. Mode-III

During braking or deceleration (Figure 2.3), the EM acts as a generator to charge the battery via the power converter.

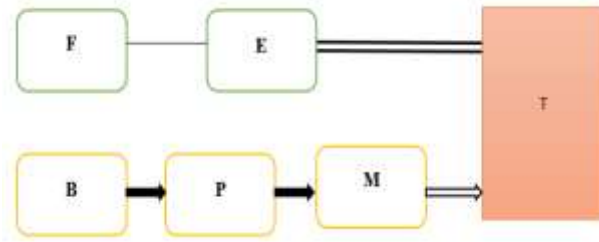

Fig. 2c Braking or deceleration

D. Mode-IV

Under light load condition (Figure 2d), the traction power is delivered by the ICE and the ICE also charges the battery via the EM.

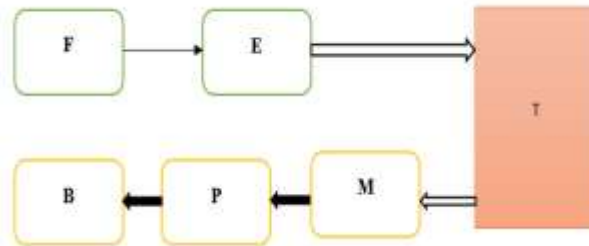

Fig. 2d light load

B: Battery G: Generator E: ICE F: Fuel tank

M: Motor P: Power Converter

T: Transmission (including brakes, clutches and gears)

- Mechanical link
- Hydraulic link
- Electrical link

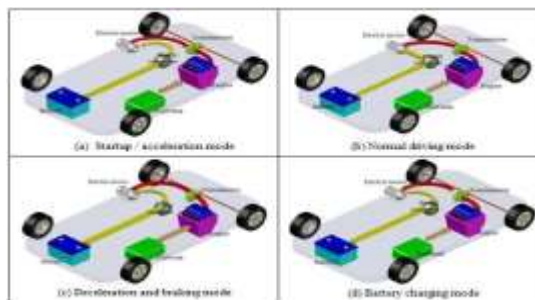

III. LIST OF VEHICLES



The parallel hybrid transmission using in following vehicles

- Honda J-VX
- Honda Insight
- Honda Dualnote
- Honda Fit Hybrid
- Honda Fit Shuttle
- Honda Civic Hybrid
- Honda Accord Hybrid
- Honda Freed Hybrid
- Honda CR-Z
- Acura ILX Hybrid

**Honda J-VX :** The Honda J-VX was the first hybrid sports car concept to employ Honda's Integrated Motor Assist electric hybrid system and was initially unveiled at the Tokyo Motor Show in October, 1997. It achieved 70mpg (30km/l) and featured a 1.0 liter, 3 cylinder VTEC engine, supercapacitor electrical storage, an all-glass roof, airbag-like "air belts", used lightweight materials, and aerodynamic design. Eventually it would evolve into the Honda VV, a Pre-production prototype of the Honda Insight.

**Honda Insight:** The Insight uses the first generation of Honda's [Integrated Motor Assist](#) (IMA) hybrid technology. The gasoline engine is a 67 hp (50 kW; 68 PS), 1.0 litre, [ECA series 3-cylinder](#) unit providing lean burn operation with an air-to-fuel ratio that can reach 25.8 to 1. The engine uses lightweight aluminum, magnesium, and plastic to minimize weight.<sup>[16]</sup> The electrical motor assist adds another 10 kW (13 hp) (at 3000 rpm) and a maximum of 36 pound-feet (49 Nm) of torque when called on, resulting in 73 hp (54 kW; 74 PS) at 5700 rpm and 91 foot-pounds force (123 N·m) of torque at 2000 rpm, with the aim to boost performance to the level of a typical 1.5 L gasoline engine.<sup>[17][18]</sup> It also acts as a generator during deceleration and braking to recharge the vehicle's batteries, and as the Insight's starter motor.<sup>[16]</sup> (This improves fuel efficiency and extends the lifetime and fade resistance of the brakes, without adding [unsprung weight](#)). When the car is not moving, for example at a stop light, the engine shuts off. Power steering is [electric](#), reducing accessory drag.

**Honda Dualnote:** The Dualnote was powered by a 3.5 litres (213.6 cu in) [double overhead camshaft](#) (DOHC) [i-VTEC V6](#) motor with Honda's [Integrated Motor Assist](#) electric hybrid system. This engine setup was estimated to produce 400 [horsepower](#) (298 kW; 406 PS) while still being capable of [fuel efficiency](#) of approximately 18 km/L (51 mpg-imp; 42 mpg-US) (5.6 L/100 km).

**Honda Fit Hybrid :** The fourth-generation Fit is offered with a new hybrid powertrain option marketed as the e:HEV, the system uses Honda's dual-motor i-MMD (Intelligent Multi-Mode Drive) hybrid system. The system combines a 1.5-litre DOHC i-VTEC four-cylinder petrol engine that on its own makes 98 PS (97 hp; 72 kW) from 5,600 to 6,400 rpm and 127 N·m (13.0 kg·m; 93.7 lb·ft) from 4,500 to 5,000 rpm with two electric motors, with one of them acting as a generator to recharge the lithium-ion battery while the other is an electric propulsion motor capable of spinning at 13,300 rpm to handle low-speed acceleration. The engine sends power to the front wheels through a single fixed-gear ratio and a lock-up clutch, which is claimed to provide a smoother transfer of torque during acceleration. The setup is claimed to be more compact and refined compared to a planetary eCVT typically found in other hybrid vehicles. The system is rated at 109 PS (108 hp; 80 kW) and 253 N·m (25.8 kg·m; 187 lb·ft) of torque.

#### IV. SIMULATION

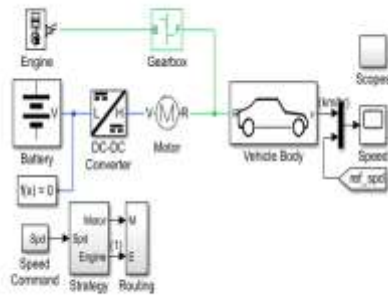

Fig. 3 Basic architecture of a parallel hybrid transmission

The Basic architecture of a parallel hybrid transmission shown in fig 3.

The function of each block explained below.

A. Engine:

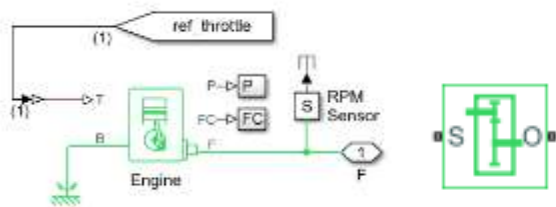

Fig. 3a Engine

Fig. 3b Gear box

B. Gear box:

The Gear Box block symbolises a nonplanetary, fixed gear ratio gearbox in its optimum state. The gear ratio is calculated by dividing the angular velocity of the input shaft by the angular velocity of the output shaft. Connections S and O are mechanical rotational conserving ports associated with the box input and output shaft, respectively. The block positive directions are from S to the reference point and from the reference point to O.

C. DC Voltage Source :

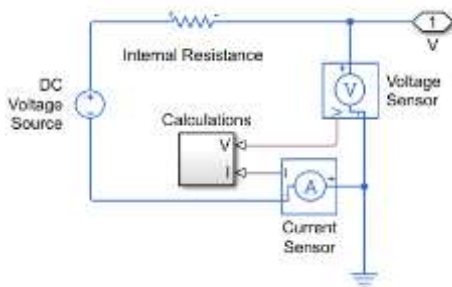

Fig. 3c Dc Voltage source

The DC Voltage Source block illustrates a perfect voltage source that can maintain a specific voltage at its output regardless of the current flowing through it. The Constant voltage parameter, which can be positive or negative, is used to determine the output voltage. Connections + and - conserve electrical ports that correspond to the voltage source's positive and negative terminals, respectively. The voltage across the source is equal to the difference between the voltages at the positive and negative terminals,  $V(+)-V(-)$ , and the current is positive if it flows from positive to negative.

D. DC-DC Converter:

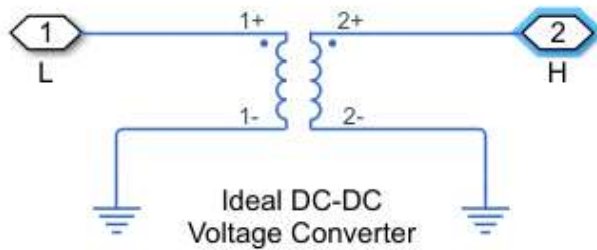

Fig. 3d DC-DC Converter

A behavioural model of a power converter is represented by the DC-DC Converter block. On the load side, this power converter adjusts voltage. The required quantity of power is extracted from the supply side to balance input power, output power, and losses. The converter can also enable regenerative power transfer from the load to the supply.

E. Motor:

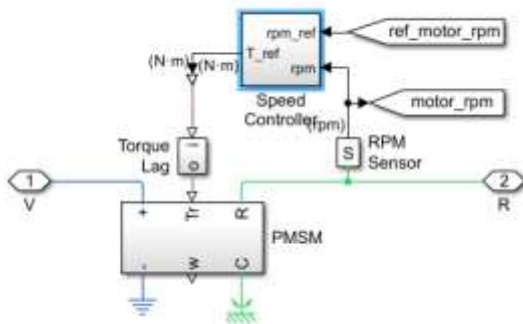

Fig. 3e Motor

PMSM is controlled by speed controller and speed is measured by speed sensor.



F. Speed Command :

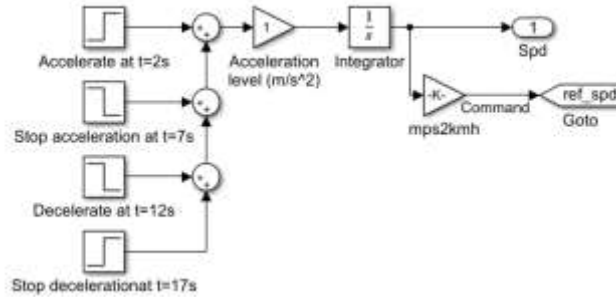

Fig. 3f Speed Command

Speed command block used to assign the accelerate deaccelerates timings.

G. Strategy :

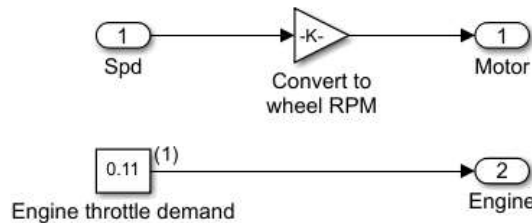

Fig. 3g Strategy

This block receives the Speed data as an input from the Speed command block. It's converted to wheel revolutions per minute and passed to the Routing Block. The engine throttle demand has been designed so that the combustion engine provides just enough power to keep the vehicle moving at a steady speed when the vehicle is started, and so battery power is near to zero.

VI. RESULTS

A. Effect of follower(F) to base(B) teeth ratio (NF/NB)

To observe the effect of teeth ratio of gear box we changed value of followed to base ratio to 8.5.

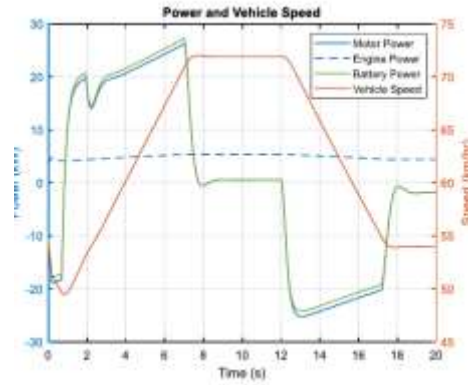

The motor and battery dissipate more power in the initial phase, as shown in the graph above, while the rest of the phases remain the same as before adjusting the follower to base teeth ratio.

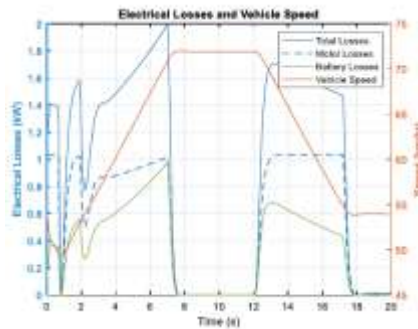

It can be seen from the electrical losses and vehicle speed plot that during the first phase, due to higher power dissipation, motor and battery losses alter as well.

### B. Change in Battery Pack Voltage

Honda Civic features 132 battery cells, each of which is rated at 1.2 volts, for a total battery pack voltage of 158.4 volts (132 x 1.2 V). Nickel-metal hydride batteries with a capacity of 5.5 Ah and a volume decrease of 12%. We changed the constant voltage from DC Voltage Source from 201.6 to 170V in this experiment. We also noticed that the winding ratio of the DC-to-DC voltage converter has changed from 500/201.6 to 500/170 as a result of these alterations.

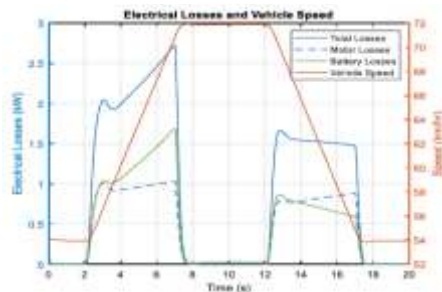

As the DC-to-DC voltage converter's winding ratio grew, the battery voltage decreased. The electrical losses plot shows that battery losses have increased, resulting in an increase in overall electrical losses during the acceleration and deceleration phases. As a result of this experiment, we can deduce that increasing the battery voltage will result in minimal battery losses.



### C. Change in Torque control time constant of motor and Drivenge in Battery Pack Voltage

To observe the effect of torque control time constant ( $T_c$ ) we changed value from 0.3 to 0.6. The power and vehicle speed plot shows that while the vehicle speed is constant, the battery and motor power increases slightly, and when the vehicle speed is steady and in deceleration mode, the battery and motor power declines suddenly.

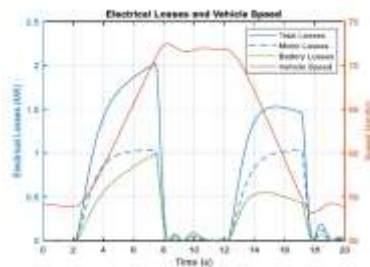
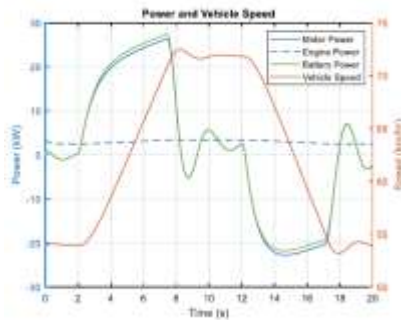

Electrical losses and vehicle speed figure shows that while the vehicle speed is constant, battery and motor losses grow somewhat, and when the vehicle speed is constant and in deceleration mode, battery and motor losses reduce dramatically.

## VI. CONCLUSION

The simulation findings reveal that the transmission system design has an impact on vehicle performance, and the parallel hybrid vehicle employs the combined power of the two power units.

Using the MATLAB simscape tools, this paper explored the variance of key parameters and elaborated on the understanding of the parallel hybrid system.

It is understood that the energy management system and control techniques have an effect on fuel consumption, air pollution, and hybrid vehicle performance in various driving cycles depending on specific characteristics.

## REFERENCES

- [1] C. C. Chan, "The state of the art of electric, hybrid, and fuel cellvehicles,"Proc. IEEE, vol. 95, no. 4, pp. 704-718, Apr. 2007.
- [2] H.Moghbeli, A.Saleki , S.Rezazade, "Design and Simulation of electric drive for hybrid vehicle Runna," National Conference of Technology , Energy and Data on Electrical & computer engineering [In Persian], May2015.
- [3] T. Markel and K. Wipke, "Modeling grid-connected hybrid electric vehicles using ADVISOR," Sixteenth Annual Battery Conference on Applications and Advances. Proceedings of the Conference (Cat.No.01TH8533), Long Beach, CA, 2001, pp. 23-29.
- [4] Y. Firouz, M. T. Bina and B. Eskandari, "Efficiency ofthree-levelneutral- point clamped converters: analysis and experimental validation of power losses, thermal modelling and lifetime prediction," in IET Power Electronics, vol. 7, no. 1, pp. 209-219, January 2014.
- [5] Rahman, Z., Butler, K, and Ehsani, M., "A Comparison Study Between Two Parallel Hybrid Control Concepts," SAE Technical Paper 2000-01-0994,2000.
- [6] M. J. Mojibian and M. Tavakoli Bina, "Classification of multilevel converters with a modular reduced structure: implementing a prominent 3 I-level 5 kVA class B converter," in IET Power Electronics, vol. 8, no. 1, pp. 20-32, 1 2015.
- [7] <https://www.sciencedirect.com/topics/engineering/parallel-hybrid-configuration>