



DESIGN OF TRANSFORMER LESS UPFC BASED ON MULTI LEVEL INVERTER

Raja Reddy. Duvvuru

Associate Professor, Malla Reddy Engineering College (A), Hyderabad, Telangana, India

K. Anitha Reddy

Assistant Professor, Malla Reddy Engineering College (A) Hyderabad, Telangana, India

Narendra Kumar.Ch

Associate Professor, Malla Reddy Engineering College (A), Hyderabad, Telangana, India

R. Siva Sai Rama Krishna

Technical Associate, Tech Mahindra, Hyderabad, Telangana, India

A.V. Sudhakara Reddy

Associate Professor, Malla Reddy Engineering College (A), Hyderabad, Telangana, India

Rajesh Reddy. Duvvuru

Assistant Professor, Narayana Engineering College, Gudur, Andhra Pradesh, India

ABSTRACT

The conventional Unified Power Flow Controller (UPFC) exists two back 2 back inverters and more complex zigzag transformers for isolation and accomplishment high power & voltage ratings. To overcome these difficulties, two zigzag transformers are wholly eliminated in this place two cascaded multi-level inverters are presented. The single configuration and control of two CMIs as a power flow controller lead to the possible to separately control real and reactive power over a transmission line. The proposed configuration is exceptional features and several advantages over the traditional UPFC such as transformer less, high efficiency, light weight, low cost, high reliability and fast dynamic response. In this work, Fuzzy Logic Controller (FLC) is design to improve the system performance. In this work is done by MATLAB/Simulation model.

Key words: Multi level inverter, Transformer, CMI, UPFC, FLC

Cite this Article: Raja Reddy. Duvvuru, K. Anitha Reddy, Narendra Kumar.Ch, R. Siva Sai Rama Krishna, A.V. Sudhakara Reddy and Rajesh Reddy. Duvvuru, Design of Transformer Less UPFC based on Multi Level Inverter, *International Journal of Electrical Engineering and Technology*, 11(4), 2020, pp. 122-134.

<http://www.iaeme.com/IJEET/issues.asp?JType=IJEET&VType=11&IType=4>

1. INTRODUCTION

The radial system are presented to transferring power with less reliability under uncertainty conditions, to avoid this problem have implemented the grid system. In recent days, power capability in grid system has to empower load ability of line, but additional control devices are used to get better performance operation and reliability. Hence, solution for power flow control in grid network, no limit for reactors, SSSC, UPFC and so forth. And also providing better solutions for power quality issues we are using custom power devices like STATCOM, DVR, and UPQC. Generally, the principle of FACTS has to enlarge capability and controllability of power transmitted in ac-system [1]. Comparing to past 20 years ago, this is drastically change came to our world. We need efficient and fast operating devices. Thus our electrical engineering mixed with combining mechanical & electronics engineering for providing fast and efficient equipment. These are sensitive and sophisticated devices manufacturing with mostly electronic components. In today life, large transformers are utilized in several appliances that are FACTS equipment are example to reach values in grid system. This requirement is provide to power flow controlled in transmission system. Generally, large transformers have following limitations are high priced, massively, energy wastage and collapse at few disturbances in system. Therefore system is not capable for sudden changing in power flow conditions. These problems are eradicated by introducing the power electronic devices. These devices are providing to large power and increasing power controls for utility applications.

2. MULTI-LEVEL INVERTERS

Multi-level inverter was brought into application by Dr. Nabae in 1981. This type inverters were classified with different strategies is: diode-clamped type, flying capacitor type and cascade multilevel type have developed [2]. So these inverters have following advantages are:

- Very low voltage dv/dt and low distortion in output-voltage waveforms.
- Small distortion in current at input waveforms.
- Low common node voltage.
- Facilitate the utilization of commercial low voltage devices in high/medium voltage applications.
- Minor switching losses because used short switching frequency.

Meanwhile, dominance shared by multilevel arrangement, these obtained more benefits and limitations of different strategies. This diodes can raises the cost but also cause problems and presents parasitic inductances. The FCI require large capacitance, and its complicated control. Also, to maintain each capacitor voltage this needs the high-switching frequency. Comparatively, modular implementation of CMI is best suited and it's able to develop multi-step voltage waveform in form of staircase, when increasing the no. of levels while approaching nearer to sinusoidal output voltage. Moreover, there are no need additional circuits for voltage balancing at dc link. Therefore structure design and layout is simple, hence it builds more useful for high voltage and huge energy applications. Commonly, multilevel inverter is classified into two major types are Fundamental Frequency Modulation (FFM) and second one is Pulse Width Modulation (PWM) are utilized. Every device of FFM is simply switches to develop a voltage, the no. of levels is increasing while approaching a sinusoidal output-voltage [5].

3. APPLICATIONS OF MULTI-LEVEL INVERTER IN FACTS DEVICES

Above mentioned FACTS controllers, no substance in either transmission level or distribution level, have to response on heavy and difficulty of zig-zag transformers for output voltage and isolation requirement. Multi-level inverter is to build up technologies, particularly CMI has to utilize in FACTS application of multilevel design. The CMI based STATCOMs have been established in Europe and Asia (up to 200Mvar). Moreover, it can also demonstrate that CMI has based SSSC can coupled direct to transmission line without coupling transformer [3].

In despite of, the CMI could not couple directly to general UPFC, because it requires two inverters deal with real power ex-change. This problem can solved, a UPFC with CMI,s was introduced to eradicate of zig-zag transformers, Fig.1 shows at Circuit configuration of UPFC, that needed the normal multi-pulse inverter based UPFC and still required a isolation transformer [4-5] .

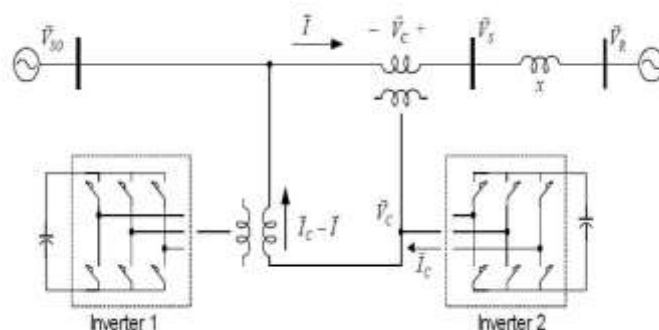
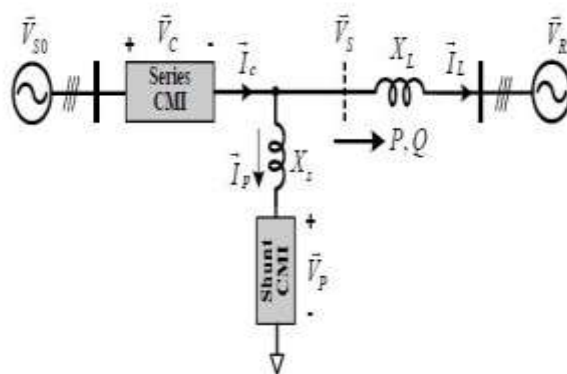

Figure 1 Circuit configuration of UPFC.

The transformer is eliminated totally, a new transformer-less UPFC has been proposed with novel configuration of two CMIs [6]. The system configuration is shown at Fig.2 (a). This arrangement UPFC exists two CMIs, one is series CMI, and it associated in series with line and the other shunt CMI, which parallel connected afterwards series CMI at sending end respectively. Each CMI has built of series cascade H bridge modules as shown Fig.2 (b) [7].



(a)

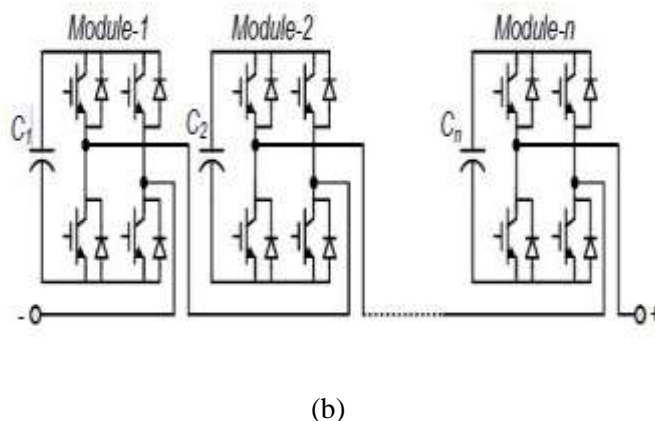

Figure 2 (a) Novel configuration of transformer-less UPFC (b) One phase of cascaded multilevel inverter.

4. CONTROL OF TRANSFORMERLESS UPFC

4.1. Dynamic Models of UPFC

In previous section, equations are restricted to steady-state analysis operation. A vector-oriented control is implement to perform dynamic conditions also for proposed transformer less UPFC, the dynamic modules is mandatory. And it based on synchronous reference (dq) outline. Voltage (V_{s0}) at actual sending end for the phase-angle is achieved from digital phase-locked loop (PLL), while abc to dq transformation used. In entire system, A dynamic models are illustrated at Fig.3 will classified into various parts, In dynamic models, voltages are from new sending end to user end bus is:

$$\begin{cases} V_{sd} = R_L i_{Ld} + L_L \frac{di_{Ld}}{dt} - \omega L_L i_{Lq} + V_{Rd} \\ V_{sq} = R_L i_{Lq} + L_L \frac{di_{Ld}}{dt} + \omega L_L i_{Ld} + V_{Rq} \end{cases} \dots\dots (1)$$

Since, the series-CMI voltage V_c is subtracted from actual voltage V_s is equal to new voltage V_{s0} at sending end, are

$$\begin{cases} V_{cd} = V_{sod} - V_{sd} \\ V_{cq} = V_{soq} - V_{sq} \end{cases} (2)$$

Further model from new sending end to shunt CMI is

$$\begin{cases} V_{sd} = R_s i_{Pd} + L_s \frac{di_{Pd}}{dt} - \omega L_s i_{Pq} + V_{pd} \\ V_{sq} = R_s i_{Pq} + L_s \frac{di_{Pd}}{dt} + \omega L_s i_{Pd} + V_{pq} \end{cases} \dots\dots (3)$$

4.2. Overall DC Voltage and Power Flow Control

It is desired to implement a control system, that stabilizes independently of P & Q over line, then similar as capacitor voltages of two CMIs has maintain at given values. While they are parted into three stages, that are stage-I, stage-II and stage-III.

Stage-I: The \vec{V}_{c0}^* and \vec{I}_{p0}^* are calculated from P^*/Q^* . As mentioned earlier, the \vec{V}_{c0}^* is series-CMI voltage as reference, that developed according to transmitted power ordered is

specified, while $\overrightarrow{I^*_{p0}}$ is reference for shunt-CMI current, which keeps the zero active power for two CMIs are specified. Therefore, the $\overrightarrow{V^*_{c0}}$ is calculated alternative way instead of directly calculated. Reference line currents are I^*_{Ld}/I^*_{Lq} are computed with P^*/Q^* reference, then d- & q-axis components of series voltage V^*_{c0d}, V^*_{c0q} are determined. This includes the first dynamic model. Then current was controlled through a decoupling feed-forward control, so it achieved the better dynamic response for the line current [8].

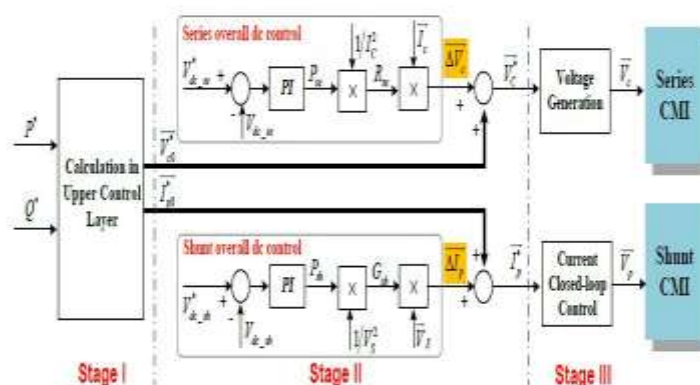
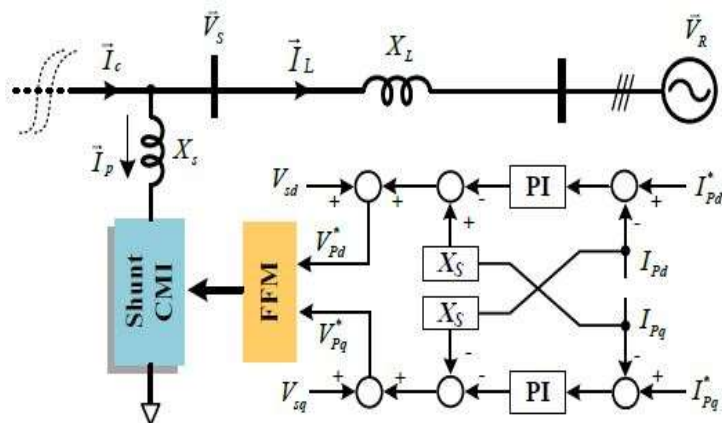

Figure 3 Overall DC voltage and power flow control

Stage-II: Overall dc-link voltage regulation. In previous stage a dc link voltage cannot sustained because followed three causes are, 1)the CMIs always have a power loss, 2) parameters deviations at error calculation and 3) error between actual and reference output. To maintain a dc link voltage with robust designs and variables of $\overrightarrow{\Delta V_c}$, $\overrightarrow{\Delta I_p}$ are presented for voltage regulation at dc link for series and shunt CMIs respectively, shown in Fig.3. Respectively $V^*_{dc_se}$ and $V^*_{dc_sh}$ is series and shunt CMIs references of dc voltages and V_{dc_se} and V_{dc_sh} are averaged for both CMIs of dc feedback [9].

For series-CMI, P_{se} is the output of overall dc-link voltage regulation loop, R_{se} is determined by ratio of P_{se} to I^2_{se} , finally $\overrightarrow{\Delta V_c}$ is produced with R_{se} and series-CMI current $\overrightarrow{I_c}$, which considered as active voltage component. When $P_{se} = P_{loss}$, resistance R_{se} are balanced for dc link and series CMI. For shunt-CMI, $\overrightarrow{\Delta I_p}$ is introduces for DC voltage control in same manner.

Stage-III: Generation of voltage for series and current for shunt CMIs respectively. For shunt CMI, output current can control by feedback signal of current with $\overrightarrow{I^*_p}$ as reference current, illustrated at Fig.4 (a,b) whereas, output of series CMI voltage can generated directly from $\overrightarrow{V^*_c}$ by FFM [10].



(a)

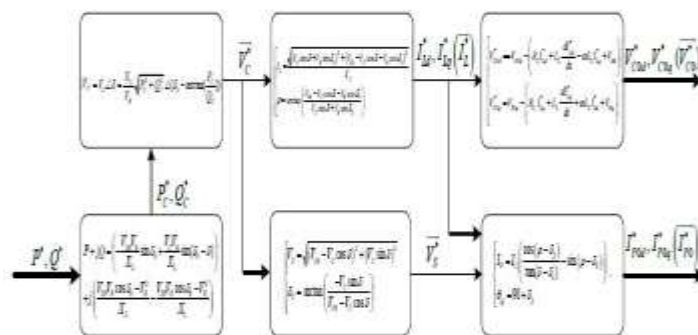

(b)

Figure 4 (a) Closed loop current for shunt CMI (b) P^*/Q^* to $\overline{V_{c0}^*}$ and $\overline{I_{p0}^*}$ calculation.

The given Fig.5 transformer less UPFC are proposed with desired control and modulation strategies, proposed system of 4160V are implemented in Matlab/simulink and the voltage $\overline{V_R}$ at sending end is similar amplitude of actual voltage $\overline{V_{s0}}$ at sending end, hence a 30° phase lagging. A transformer2 are establishes that 30° phase lagging difference with Y/Δ arrangement. Basic functions of UPFC are implemented this system [11].

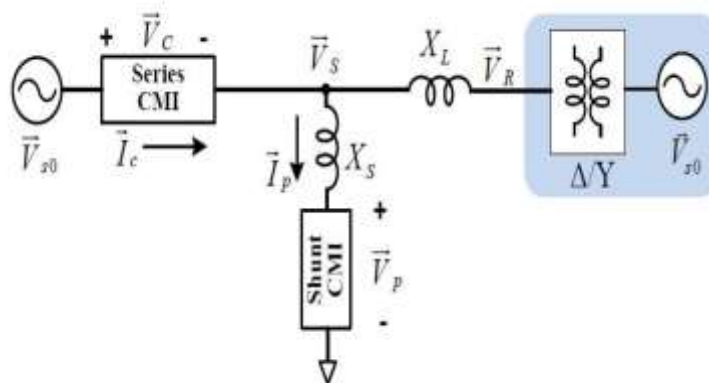

Figure 5 Equivalent circuit of transformer less UPFC.

5. FUZZY LOGIC CONTROL

5.1. Introduction to Fuzzy Logic

Fuzzy logic is another class of artificial intelligence, but its application in control theory has been developed in recent days. According to George Boole, humanoid thinking are based on yes/no or 1/0 logic. But the human thinking does not always follow the crisp logic yes/no, but this is qualitative, uncertain, and imprecise in nature. Based on the imprecise inputs, Lotfi Zadeh an Irish computer scientist developed fuzzy logic or fuzzy set theory. In the developing days it was highly criticized by the professionals, but in recently it is emerged as the new discipline of artificial intelligence.

The control architecture of process which is based on FL is defined as fuzzy control. A fuzzy control system specifically embeds experience and perception of a human plant operator. The design of normal control system is constructed on mathematical modeling of system. But this mathematical implementation is complex to design. On the other hand fuzzy control does not need any mathematical model and mainly on operator experience and heuristic. Fuzzy logic found in several applications specifically in power electronic controls at recent days. The generalized designing procedure for fuzzy control given as follows[12].

- At first, analyse the whether the system elements to warrant to FL applications.
- Collect all the information regarding the system parameters to be controlled.
- Identify the main elements where FL to be implemented.
- Identify input and output variables of each fuzzy system.
- Design the corresponding membership function (MF) for each variable.
- Formulate fuzzy rule table.
- Using defuzzification method to get required output.

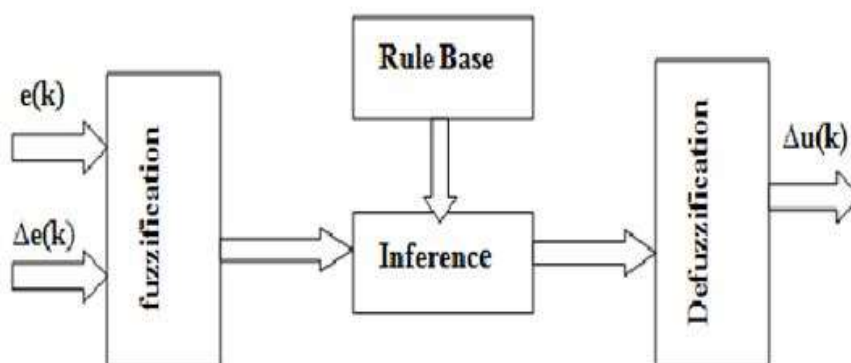

Figure 6 Block diagram of operation of FL.

Fuzzy logic execution of block diagram is presented in Fig.6, in which it contains mainly three basic blocks called as fuzzification, inference and defuzzification.

5.2. Fuzzification

Fuzzification is process where the numerical or any other format of input data is converted into fuzzy membership functions (MF). In FL there are so numerous types of membership functions like triangular membership function; trapezoidal membership function, Gaussian membership function etc. are available in fuzzy toolbox. Here the input variable is error and

change in error and output variable is change in duty cycle. The suitable membership functions are implemented for these variables.

5.3. Inference

The actual rules are given in this block. A suitable operator like AND, OR and NOT will be selected and IF-THEN rules are implemented. Select the appropriate operator between input variables. The rules are framed on knowledge base as human thinking.

5.4. De-fuzzification

Till now the result of implication and aggregation step is the fuzzy output, and union of all individual membership functions are validated. Conversion of this fuzzy output into crisp output is called defuzzification. Some of defuzzification methods like centre of area or centre of gravity, height method and mean of maxima methods are available. In this work centre of gravity (COG) method is utilized for de-fuzzification. Crisp output Z_0 of the Z variable is considered as geometric center of output fuzzy value $\mu_{out}(Z)$ area, where $\mu_{out}(Z)$ of is formed by taking union of all contributions of all rules. The general expression of COG defuzzification is

$$Z_0 = \frac{\int Z \cdot \mu_{out}(Z)}{\int \mu_{out}(Z) dZ} \quad (4)$$

With discretized universe of discourse, the expression is

$$Z_0 = \frac{\sum_{i=1}^n Z_i \mu_{out}(Z_i)}{\sum_{i=1}^n \mu_{out}(Z_i)} \quad \dots \quad (5)$$

COG method of defuzzification is well known method in fuzzy systems as it is simple and fast.

Fuzzy logic for transformer less UPFC pulses is implemented using Matlab/Simulink fuzzy logic toolbox. The fuzzy logic toolbox is user friendly program developed in the Matlab environment. There are mainly five graphical tools used for building, editing, and witnessing of fuzzy inference system in fuzzy toolbox.

- Fuzzy inference system (FIS) editor
- Membership function editor
- Rule base editor

5.5. FIS Editor

After opening the fuzzy toolbox, FIS editor opens which displays general information about fuzzy system and this FIS editor is presented in Fig.7.

At left side of the top of editor consist of input variables and right side is output variables. MFs is shown in diagram is simple icons and there are not actual MFs. It is containing system name and inference method are indicated at below and right side the variable name for the associated MFs are given. All the viewer and editor boxes shows development of controlling the system.

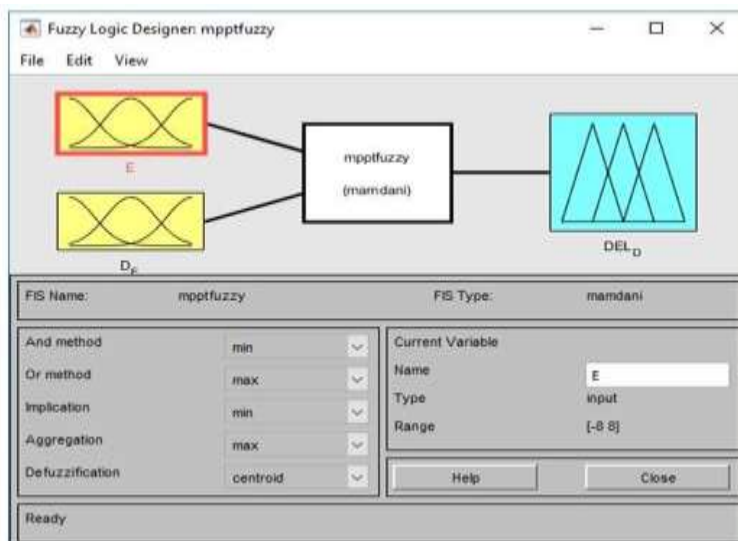

Figure 7 Fuzzy interfacing editor

5.6. Membership Function Editor

In proposed fuzzy system there are two input variables and single output variables are implemented. Input variables of fuzzy system are error (E), change in error (ΔE) and output variable is change in duty cycle (ΔD).

Error and change in error values are given as input to FIS editor and the MFs function for this input and out variables are given in fig.6. shows the MF of input variable error (E) and this work triangular based MF functions are considered.

6. SIMULINK DESIGN AND RESULTS

Simulation results are performed in Matlab/Simulink. In Simscape Power System toolbox is used for implementation of transformer less UPFC. Fig.8.4 (a,b) shows simulation model implemented in simulink and internal block diagram. Control structure is implemented as from proposed system and it helps for system stability and provides smooth variation at any changes in loadability as well as power commands in system.

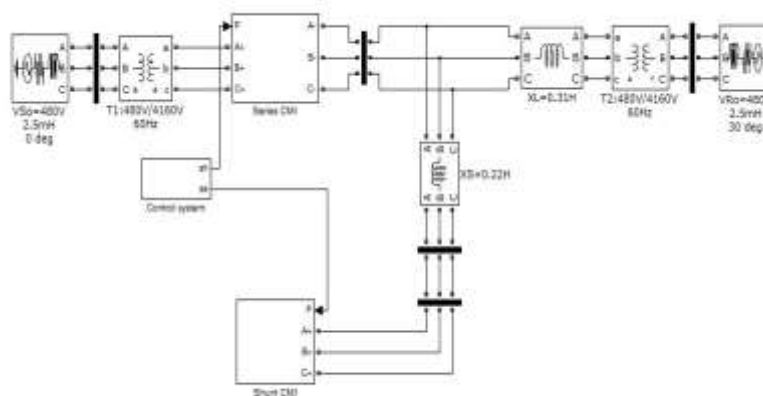

Figure 8 (a).Simulation model for proposed system

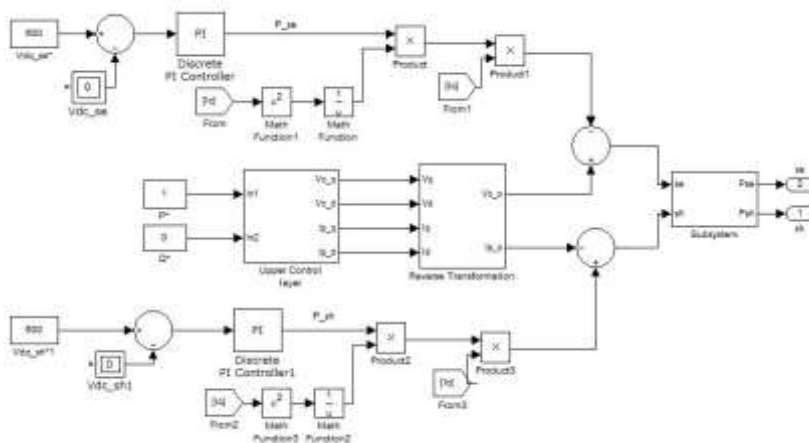

Figure 8 (b) Internal block diagram simulink block

6.1. Phase Shifting Control

Case1 to Case2:

From case1 to case2 (30° to 15° phase shift). In previous, there is 30° phase difference between voltages i.e., actual sending point \vec{V}_{S0} and receiving terminal \vec{V}_R voltages. For case1 $\vec{V}_S = \vec{V}_R$, the \vec{V}_C is injected to shift \vec{V}_{S0} by 30° lagging. Here, UPFC is compensating voltage difference caused by transformer 30° phase shift. Therefore, zero line current \vec{I}_L has achieved.

While case2, new \vec{V}_S is shifted from \vec{V}_{S0} by 15°, therefore, 15° phase difference between \vec{V}_S and \vec{V}_R is 15°. These results, 7.3A line current \vec{I}_L . Fig.(9) shows shunt-CMI line voltage V_{Pab} and line current \vec{I}_L . FFM have been generated with low THD of shunt-CMI phase voltage, even line-voltage has lesser THD because triplen harmonics in balanced system are absented and it is nearer to sinusoidal where doesn't usage extra filters. Here current easily and speedily raised from 0 to 7.3A, when operating point is changed from case1 to case2.



Figure 9 Shunt-CMI line voltage V_{Pab} and line current \vec{I}_{La} in case1 to case2.

Case2 to Case3:

Like wise, case2 to case3 (15° to 0° phase shift). For case3 indicates a system has without compensation for 0° phase shift, then $\vec{V}_s = \vec{V}_{s0}$ and difference of \vec{V}_s & \vec{V}_R is 30° . Hence, resulting current around 14.5A.

FFM has generated V_{pa} and V_{pb} with optimal firing angles, these are form in staircase. Then, shunt-CMI phase voltage V_{pa} & V_{pb} and line currents are I_{La} , I_{Lb} and I_{Lc} is illustrated at Fig.10 & 11.

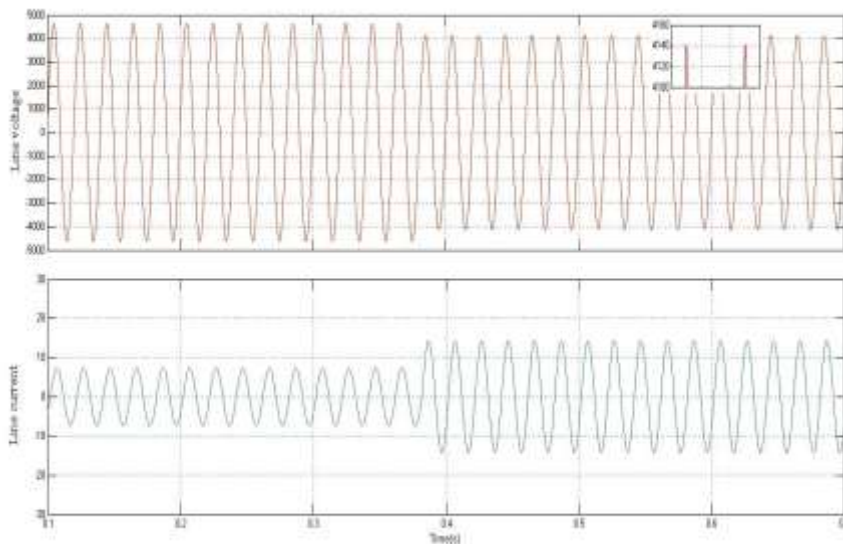

Figure 10 Shunt-CMI line voltage V_{pab} and line current \vec{I}_{La} in case2 to case3.

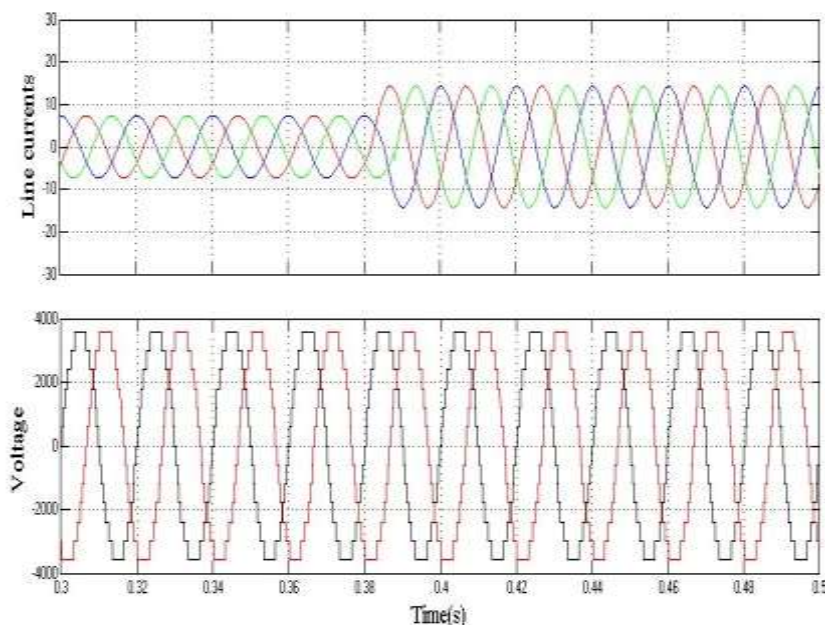

Figure 11 In mode1 to mode2, Line currents are I_{La} , I_{Lb} and I_{Lc} and shunt CMI phase voltages V_{pa} & V_{pb} .

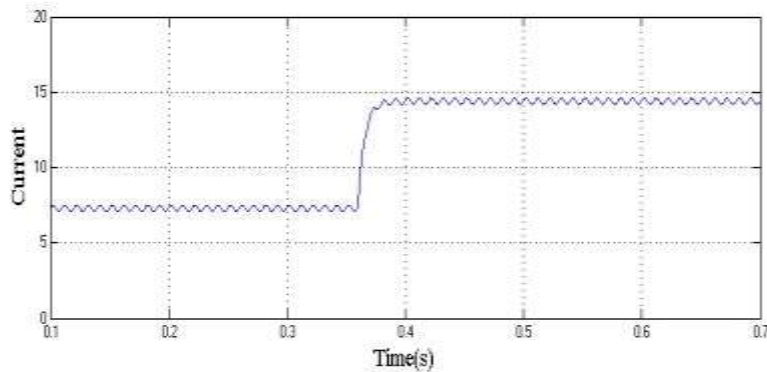

Figure 12 Dynamic response for changing case2 to case3.

The operating point changed from case2 to case3, then current is rapidly increases from 7.3A to 14.5A (amplitude) as shows Fig 12.

7. CONCLUSION

Hence, the cascaded multilevel inverter are used to eliminate the large transformers, generates output nearer to sinusoidal waveform and fast dynamic response. The controlling of new transformer less UPFC has successive improvements are extremely lower switching losses, greater efficiency of CMI by using FFM technique, all UPFC functions are achieved and quick dynamic response of the system. The operation and performance of new transformer less UPFC have been analyzed by using MATLAB/Simulink model. In proposed system FLC is improved the system performance and it gives better performance compared to conventional PI controller.

REFERENCES

- [1] N. Hingorani and L. Gyugyi, (2000) *Understanding Facts: Concept and Technology of Flexible AC Transmission Systems*. Piscataway, NJ, USA: IEEE Press.
- [2] B. Gultekin and M. Ermis, (2013) "Cascaded Multilevel Converter-Based Transmission STATCOM: System Design Methodology and Development of a 12 kV 12 MVar Power Stage," *Power Electronics, IEEE Transactions on*, vol. 28, pp. 4930-4950.
- [3] F. Peeng, J. S. Lai, J.W. McKeever, and J. Van Coevering, (1996) "A multilevel voltage-source inverter with separate dc sources for static var generation," *IEEE Trans. Ind. Appl.*, vol. 32, no. 5, pp. 1130–1138.
- [4] H. Fujita, H. Akargi, and Y. Watanoble, (2006) "Dynamic control and performance of a unified power flow controller for stabilizing an AC transmission system," *IEEE Trans. Power Electron.*, vol. 21, no. 4, pp. 1013–1020.
- [5] L. Liu, P. Zhu, Y. Kang, and J. Chen, (2007) "Power-flow control performance analysis of a unified power-flow controller in a novel control scheme," *IEEE Trans. Power Del.*, vol.22, no. 3, pp. 1613–1619.
- [6] T. Yang, Y. Liu, X. R. Wang, D. Gunasekaran, U. Karki, and F. Z. Peng, (2015) "Modulation and Control of Transformer-less UPFC," *IEEE Transactions on Power Electronics*, vol. PP, pp. 1-1.
- [7] Z. Peng, S. Zhang, S. T. Yang, G. Deepak, and K. Ujjwal, (2014) "Transformerless unified power flow controller using the cascade multilevel inverter," in *Proc. Int. Power Electron. Conf.*, pp. 1342–1349.

- [8] H. Akagi, S. Inoue, and T. Yoshii, (2007) "Control and performance of a transformerless cascade PWM STATCOM with star configuration," IEEE Trans. Ind. Appl., vol. 43, no. 4, pp. 1041–1049, Jul./Aug.
- [9] B. Gultekin, C. O. Gercek, T. Atalik, M. Deniz, N. Bicer, M. Ermis, K. N. Kose, (2012) "Design and implementation of a 154-kV 50-Mvar transmission STATCOM based on 21-level cascaded multilevel converter," IEEE Trans. Ind. Appl., vol. 48, no. 3, pp. 1030–1045, May/Jun.
- [10] J. Wang and F. Z. Peng, (2004) "Unified power flow controller using the cascade multilevel inverter," IEEE Trans. Power Electron., vol. 19, no. 4, pp. 1077–1084.
- [11] F. Z. Peng, J.W. Mckeever, and D. J. Adams, (1997) "Cascade multilevel inverters for utility application," in Proc. Conf. IEEE Ind. Electron. Soc., Nov. pp. 437–442.
- [12] J. Arun Naik (2018) "Fuzzy Controlled Transformer-Less Upfc For Ac Grid With Cascaded Multilevel Inverters" International Journal of Management, Technology and Engineering, Volume 8, Issue IX, September/2018, pp: 1-8.