

Effect of Tool Overhang Length on Turning Operation Using Finite Element Model

B.TULASIRAMARAO, P. RAMREDDY, K. SRINIVAS, A.RAVEENDRA

Abstract: Turning surface accuracy and high productivity rates have become the vital determinants and both the accuracy and surface quality plays vital role. In this paper the cutting tool modeled with finet element model and for different tool overhanging lengths analytical modal has prepared. The modal and stiffness data of the tool are extracted from ANSYS software also the mode shapes were drawn. Tool overhang was selected as input and the influences of tool overhangs on the stability of turning using finite element was obtained. The stability lobe diagrams corresponding to different tool overhangs different stiffness, tool frequencies and damping ratios were presented.

key words- ansys software, finite element model ,tool over hang length and SLD.

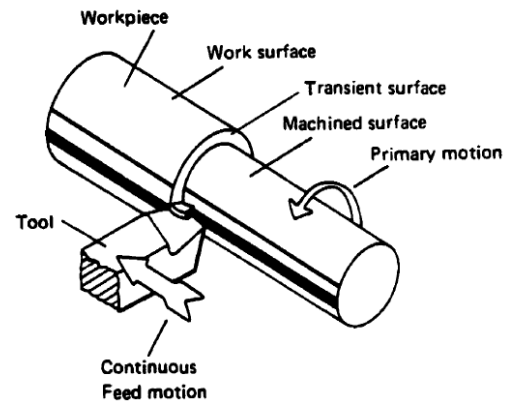

Figure 1.1 : Cylindrical turning on a lathe

I. INTRODUCTION

Turning is one of the most predominant machining operations in various manufacturing industry. In this process, work-piece rotates about its own longitudinal axis in the headstock on a machine called a lathe. The work-piece is fixed to a chuck at one end called the head stock and by a tailstock at the other end. A cutting tool which is mounted on the tool post of the lathe is fed along the work-piece parallel to the longitudinal axis to remove the excess material and produce the required shape. In a basic turning process, there are several parameters that define the cutting conditions of the work piece. They are feed rate of the tool, cutting speed of the tool, and cutting depth. Cutting speed is defined as the rate at which the uncut surface of the work-piece passes along the cutting edge of the cutting tool. Feed rate denotes is the distance moved by the cutting tool along the longitudinal direction during each revolution. Cutting depth is calculated as the thickness of the metal removed along the radial direction by the cutting tool while moving long the longitudinal direction during each revolution. Cutting depth is denoted as the thickness of the metal removed in the radial direction while revolving about the longitudinal axis. The principal surface machined is concentric with the axis of the job as shown in Fig 1.1.

Turning operations are largely used to manufacture products with accurate size and shapes in the manufacturing industry. Its applications varies from turning of dies and molds which are compact to huge jet engine accessories which are made of heat resistant alloy components, aircraft fuselage and wing panel structures, and especially biomedical parts.

1.1 stability lobe diagram

The stability lobe diagram depends on many parameters including tool stiffness, frequency, damping ratio, tool material and geometry, work piece material and its dynamics along with the cutting parameters. The cutting process parameters such as tool speed, feed rate, depth of cut provided to the tool, length of the tool etc. has a considerable influence on the chatter behavior. Higher cutting speeds leads to less production time and reduction of tool life. Comparing the feed rate with depth of cut, the latter has more influences on the stability behavior of the job. Tool overhang is defined as the length by which the tool extends from the tool holder when mounted on the tool post of the lathe.

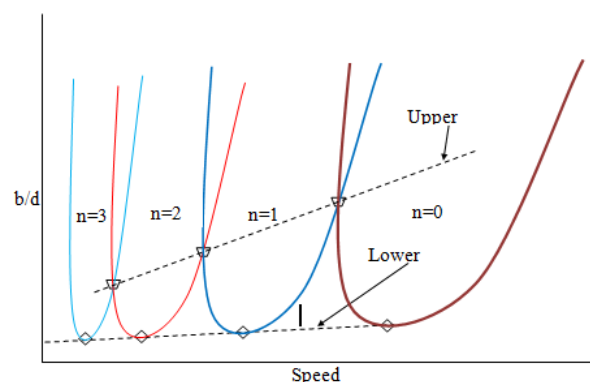

Fig.1.2 Stability lobe diagram

Length is a variable factor that can be used to tune the machining process. It acts as an absorber for the vibrations produced during machining. The stability lobe diagram has upper and lower boundaries which are also influenced by the tool wear during cutting operation.

Revised Manuscript Received on January 25, 2019.

B.TULASIRAMARAO, Research Scholar jntu, Hyderabad, Telangana, India.

Dr. P. RAMREDDY, Professor, Dept of Mech.Engg and Former Registrar JNTU, Hyderabad, Telangana,India.

Dr. K. SRINIVAS, Professor, Dept of Mech. Engg, RVR&JC College of Engineering, Guntur, AP, India.

Dr.A.RAVEENDRA, Assoc.Professor,Dept of Mech.Engg, MallaReddy Engineering College,Secunderabad, Telangana, India.

Effect Of Tool Overhang Length On Turning Operation Using Finite Element Model

1. EFFECTS OF TOOL OVERHANG LENGTH

Classical models available in literature, employed either the elastic tool or a rigid work-piece. These models may not express exactly the dynamic behavior of the system. The dynamic operation of the cutting depends on the geometrical and mechanical characteristics of the tool and work-piece. This section describes the results of tool overhang effect on the output features such as cutting edge forces and surface roughness quality. Experiments were carried out on an engine lathe machine to study the effect of tool overhang on stability. Results of finite element model of the system are also shown.

II. ANALYTICAL RESULTS

The modal and stiffness data of the tool are extracted separately from ANSYS software. Initially the solid model of the tool is developed without losing all details of the geometry, and it is meshed with solid elements. Natural frequencies, damping ratios and stiffness values are obtained first. The solid model of the tool (employed in the experiments) is generated in Autodesk-Inventor. Figure 3.1 shows the dimensions of the tools employed in the present task.

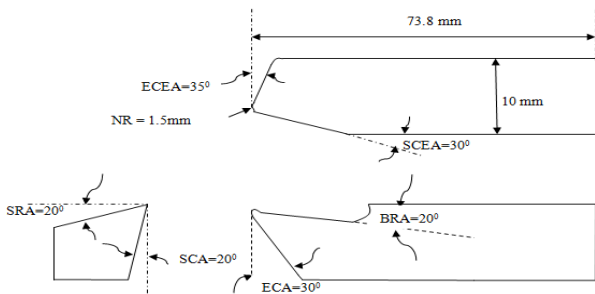

Fig. 3.1 Signature of the present cutting tool employed in solid modeling

(ECEA: End cutting edge angle, SRA: Side rake angle, BRA: Back rake angle, ECA: End clearance angle, SCA:

Table 3.1 Modal and stiffness data of tool

Tool Overhang (mm)	Stiffness(N/m)			Natural Frequency(Hz)	Damping ratio		
	K_x	K_y	K_z	ω_y	ζ_x	ζ_y	ζ_z
70	930	3301	717	112	0.0295	0.027	0.033
63	1103	3412	779	122	0.0416	0.052	0.045
55	1434	4424	1077	138	0.0425	0.043	0.05
47	2439	7310	1751	165	0.0158	0.008	0.016
39	5128	13390	3156	199	0.0428	0.042	0.026
30	5426	15680	3620	204	0.0222	0.019	0.022

The work-piece is modeled as a finite element beam with 4 elements and total 5 nodes. The following dimensions of the work-piece are considered:

- Length=480mm,
- Diameter=50mm,
- Young's modulus: 210 GPa,
- Density=7860kg/m³,
- Damping ratio $\zeta_w=0.25$,
- Rotational stiffness of the chuck $K_t=10^4$ Nm/rad.

Side clearance angle, SCEA: Side cutting edge angle, NR: Nose radius)

This is imported into ANSYS(version:8) and solid tetrahedral elements with 10 nodes (SOLID 92) and three degrees of freedom (U_x , U_y , U_z) are used to mesh the solid geometry with the following material properties: Young's modulus (E)=200 GPa,

Poisson's ratio = 0.28, Density= 8150 kg/m³.

Figure 3.2 shows the meshed geometry of the cutting tool.

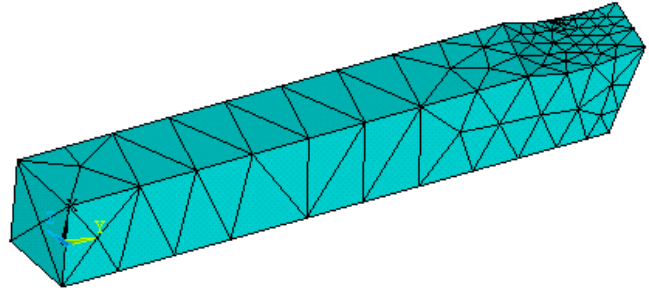

Fig.3.2 Finite element model of the present cutting tool

The amount of tool overhang is specified as the distance from tool tip to the nodal area over which the tool holder is mounted. The tool holder boundary is simulated with fixed conditions in all the directions. Thus in order to vary the overhang length, the positions of the nodes under arrest are to be changed. The stiffness of the tool is obtained from static analysis; natural frequencies are obtained from modal analysis while the damping ratios are predicted from harmonic response curves. With several values of tool overhang the modal and stiffness data of the cutting tool obtained is shown in table 3.1.

The tool interaction dynamic forces F_x act at a specified node where the cutting tool is in contact with the work piece/job. The assembled mass and stiffness matrices are obtained from the element matrices described below.

$$k = \frac{EI}{l^3} \begin{bmatrix} 12 & 6l & -12 & 6l \\ 6l & 4l^2 & -6l & 2l^2 \\ -12 & -6l & 12 & -6l \\ 6l & 2l^2 & -6l & 4l^2 \end{bmatrix}, \quad m = \frac{\rho Al}{420} \begin{bmatrix} 156 & 22l & 54 & -13l \\ 22l & 4l^2 & 13l & -3l^2 \\ 54 & 13l & 156 & -22l \\ -13l & -3l^2 & -22l & 4l^2 \end{bmatrix}$$

The first three mode shapes of tailstock supported work-piece are shown in Figure 2.3. The fundamental frequency of work-piece can be seen as 2588 rad/sec which is much higher than the equivalent work-piece without tailstock support.

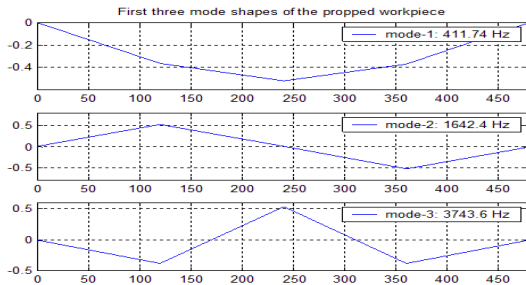

Fig.3.3 First three modes of propped cantilever work-piece

The first normalized modal vector is

$$\{\phi^{(1)}\} = [0 \ -3.3654 \ -0.3665 \ -2.416 \ -0.5205 \ -0.0132 \ -0.3688 \ 2.4098 \ 0 \ 3.4162]^T$$

This is used to un-couple the differential equations and permits all the 10 equations to express as a single second order differential equation in terms of one modal co-ordinate p_1 . The equation so obtained when the cutting tool is in contact with the work-piece at the node-4 can be written as

$$\ddot{p}_1 + 129400\dot{p}_1 + 6697744p_1 = -0.3688Cb[h_0 - v_c(t) + v_c(t - \tau) + 0.3688p_1(t) - 0.3688p_1(t - \tau)]$$

The stability lobe diagrams corresponding to different tool overhangs (different stiffness, tool frequencies and damping ratios) are presented in Figure 4.20 (a)-(c). It is seen that tool overhang has much influence on stability of cutting.

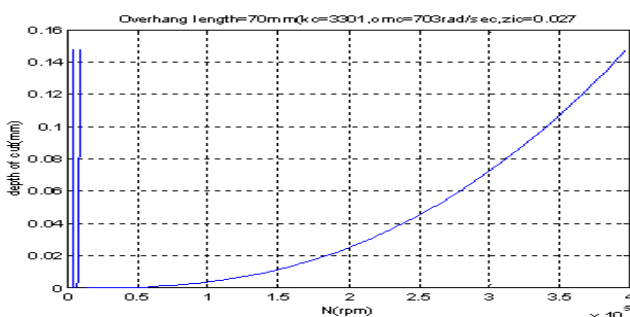

(a)

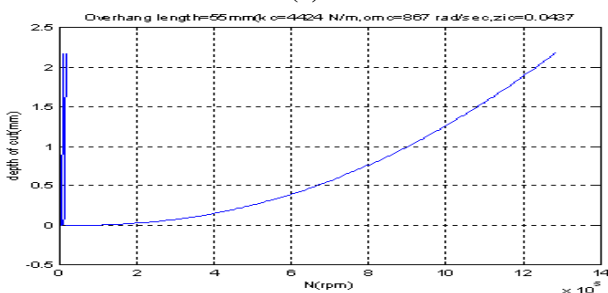

(b)

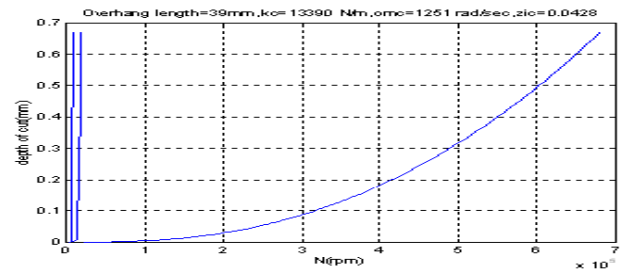

(c)

Fig. 3.4 Stability lobe diagrams at different overhang lengths.

In the diagrams, the rightmost lobe ($n=0$) at higher speeds occupies wide area and dominates the rest. It is observed that the increase in tool overhang first improves the stable depths of cut, then with further increase, again the critical depths reduces. Thus there is an optimum overhang between the extreme cases under consideration.

III. CONCLUSION

In this experimental work, stability analysis in turning process has been presented. An attempt also made to establish the influences of tool overhang on the stability of turning using finite element modeling. A model of cutting tool pertaining to Single degree of freedom was prepared from the first mode of dynamics of a three dimensional finite element model of an orthogonal cutting tool. Likewise, the work piece dynamics is arrived with finite element beam model. The tool-work interaction forces were expressed in terms of current and previous deformations of tool and work. The stability lobe diagrams with different tool overhang lengths (stiffness) were plotted.

REFERENCES

1. D.B. Welbourn and J.D. Smith, "Machine-tool Dynamics: An introduction", Cambridge, 1970.
2. J.Cook and H. Nathan, "Self-Excited Vibrations in Metal Cutting," ASME Transactions, Journal of Engineering for industry, Vol. 81, pp. 183- 186,1979.
3. S.F.Bao, W.G. Zhang, S.Y. Yu, S.M. Qiao, and F.L.Yang, "A New Approach to the Early Prediction of Turning Chatter", Journal of Vibration and Acoustics, Vol. 116, pp. 485- 488, 1994.
4. Y.S.Tarn, H.T.Young and B.Y.Lee, "An analytical model of chatter vibration in metal cutting", International Journal of Machine Tools and Manufacture, vol.34, pp.183-197, 1994.
5. Iturrospe, V. Atxa, and J.M. Abete, "State-space analysis of mode-coupling in orthogonal metal cutting under wave regeneration", International Journal of Machine Tools & manufacture, vol. 47, pp.1583-1592, 2007.
6. I.E.Minis, E.B. Magrab, and I.O.Pandelidis, "Improved Methods for the Prediction of Chatter in Turning, Part3: A Generalized Linear Theory", Trans. ASME Journal of Engineering for Industry, Vol. 112, pp. 28-35, 1990.
7. D.W.Liu and C.R. Liu, "An Analytical Model of Cutting Dynamics. Part 1: Model Building", Trans. ASME, Journal of Engineering for Industry, Vol. 107, pp. 107- 111, 1995.
8. M.N.Hamdon and A.E.Bayoumi, "Analysis for regenerative machine tool chatter", Journal of Manufacturing Science and Engineering, vol. 11, pp. 345-349,1997
9. M.N.Hamdon and A.E.Bayoumi, "An approach to study the effects of tool geometry on the primary chatter vibration in orthogonal cutting", Journal of Sound and Vibration, vol. 128(3) pp. 451-469, 1999.
10. J.R.Pratt and A.H. Nayfeh, "Design and Modeling for Chatter Control", Nonlinear Dynamics, Vol. 19, pp. 49-69, 1999.

