

# Power Quality Improvement in Integrated System using Inductive UPQC

A. V. Sudhakara Reddy\*, Md. Imran Ahmed\*, Flah Aymen\*\*, Ch. Rami Reddy\*‡,  
Ch. Narendra Kumar\*, D. Raja Reddy\*, B. Srikanth Goud\*\*\*

\* Electrical and Electronics Engineering, Malla Reddy Engineering College (A), Maisammaguda, Telangana. 500100

\*\* Research Unit of Energy Processes Environment and Electrical Systems, National Engineering School of Gabes,  
University of Gabes, Tunisia 6029

\*\*\* Electrical and Electronics Engineering, Anurag College of Engineering, Ghatkesar, Telangana. 501301  
(sreddy4svu@gmail.com, mdimranahmed.eee@gmail.com, flaheymening@yahoo.fr, creddy229@gmail.com, chnkeee@gmail.com,  
rajajntuacep@gmail.com, srikanthgoud.b@anuraghyd.ac.in)

‡ Corresponding Author: Ch. Rami Reddy, Malla Reddy Engineering College (A), Maisammaguda, Dhulapally, Secunderabad,  
Telangana. 500100, Tel: +91-9154463336, E-Mail: creddy229@gmail.com

*Received: 31.03.2021 Accepted: 18.04.2021*

**Abstract:** Harmonics pollution is very dangerous in medium power applications. Generally, harmonics are produced in the system due to the connection of nonlinear loads. This article presents a novel load voltage and current harmonic compensation, voltage sag and swells compensation approach using hybrid UPQC. The proposed synchronous reference controller uses the Carrier Pulse Width Modulation (CPWM) technique for the proper control of UPQC. The simulations are carried on Matlab/Simulink platform. The output results present the proposed hybrid UPQC compensates the load current harmonics, voltage sag and swell effectively. The load voltage harmonics are reduced from 11.65% to 1.53% and the current harmonics are reduced from 30.97% to 2.24% respectively.

**Keywords:** Inductive UPQC, Harmonic Compensation, Voltage sag, Voltage swell, Reactive power compensation

## 1. Introduction

The use of Non Linear Load (NLL) and high penetration of Renewable Energy Sources (RES) with the grid produce the harmonics. The power electronic elements are the main sources of the harmonics which degrade the quality of power received by the end-users [1]. The RES which is associated with the system at the distribution level is called Distributed Generation (DG). In the distribution networks, it is recommended to use the UPQC for harmonic compensation and reactive power compensation. The UPQC can be installed at the grid side or NLL side or DG side. Various locations of UPQC on the integrated system are shown in Fig.1. The UPQC is placed at the grid side and the NLL/RES is integrated with the grid through a special transformer [2]. It can be observed from Fig. 1, the load current harmonics will flow through the special transformer which causes serious power quality problems such as extra core losses, copper losses, vibrations and temperature rises. For this position of UPQC, it is possible to bypass the harmonics from the grid, but the effect on the special transformer is unavoidable [3]. In Fig.2, the UPQC is placed on the DG side. In this configuration also, the special transformer is affected by the harmonics. When the UPQC in this configuration, if operated in parallel with converter-based

DG systems, it loses its stability. The UPQC can perform simultaneous operations with series and Shunt Active Power Filter (SAPF). Various UPQC advancements are presented in the literature with the reduced number of switches, improved DC link voltage and better power quality production [4]. The inductive Power Filter (IPF) proposed in the literature mitigates the harmonic effect on the special transformer and also counters the source of harmonics in the system. The IPF approach uses a set of single-tuned filters. The performance of these passive filters is limited. The strength of IPF in terms of voltage regulation and harmonic compensation is better [5]. This paper presents a new inductive filter-based hybrid UPQC for the elimination of voltage and current harmonics in the integrated system as presented in Fig.3. This hybrid UPQC integrates the benefits of IPF and hybrid SAPF (HSAPF). This integration will counter the effect on special transformers due to harmonics [6]. The shunt part of the UPQC provides reactive power compensation and regulates the DC link voltage effectively for the compensation of current harmonics. Whereas the series part of UPQC regulates the voltage, compensates the voltage sag, swell and voltage harmonics. Accurate harmonic detection is very essential for the better operation of UPQC. Various researchers propose analog bandpass filters for the removal of harmonics which are very simple in structure [7].

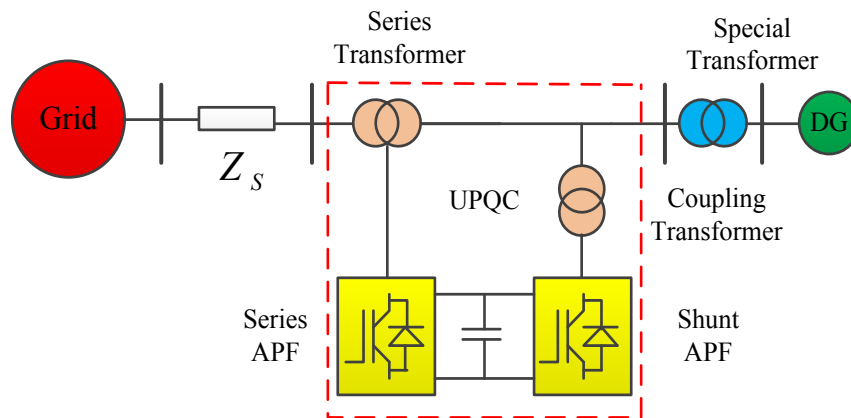

Fig.1: Grid side UPQC arrangement

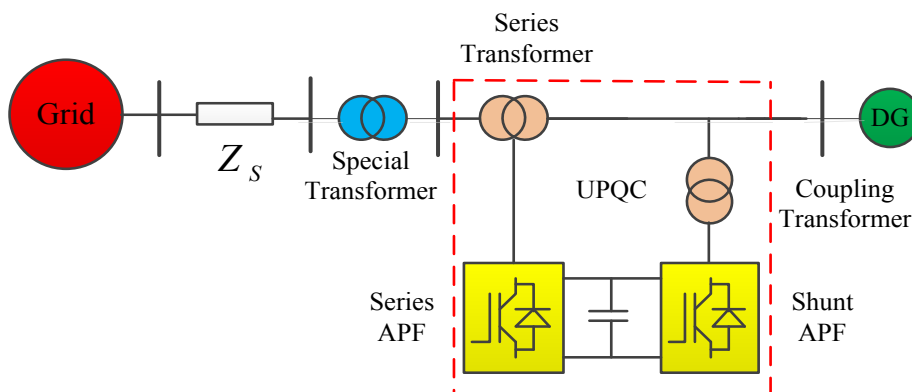

Fig.2: Load side UPQC arrangement

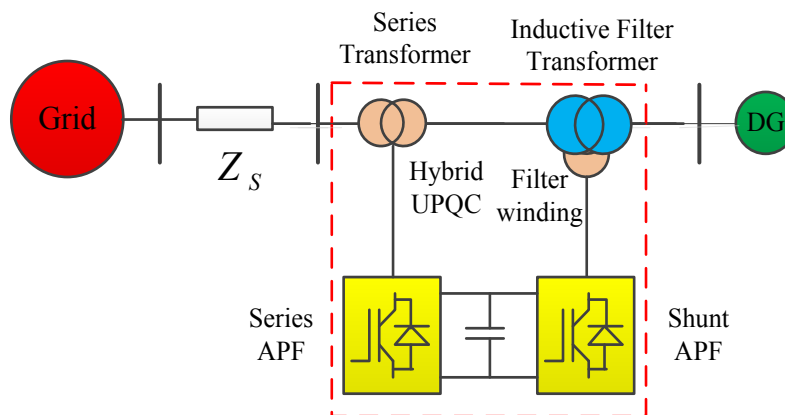

Fig. 3: Proposed UPQC arrangement

Wavelet transforms and instantaneous reactive power control theory has the shortcomings of complex structures and poor result. The dq0 method compensates the voltage and current harmonics effectively by combing the phase-locked loop with reactive power control theory and clock in phase grid frequency [8]. DC link voltage harmonics are reduced by introducing a small capacitor in series with coupling inductor of shunt active filter [9-12]]. A fuzzy logic controller for voltage sag, swell and harmonic compensation is proposed [13-15], on three phase three wire system. This controller combines the series and shunt active filters with UPQC and effectively compensates the voltage and current harmonics compared to the conventional PI controller. For the proper control of the UPQC system, the fuzzy logic control strategy and artificial neural networks are used [18-

20]. An adaptive control mechanism with radial bias neural network function is proposed in the literature, in which the parameters of PID controllers are tuned online. For reducing the switching harmonics hysteresis controllers with a random variable loop is used [21-22]. Particle swarm optimization (PSO) with adaptive neuro-fuzzy inference controller and H infinity controllers are proposed to improve the voltage and current quality [23-25]. Various optimization techniques are added additionally to the controllers like Cuckoo search [26], gravitational search, atom search, genetic algorithms, bio geography-based optimization [27-31], grey wolf optimization for enhancing the THD in the integrated system. These optimization techniques have the added advantage of reducing the THD to low value [32-37]. This paper presents the inductive UPQC for the compensation of voltage, current

harmonics, voltage sag, swell and reactive power compensation with SGDFC based Synchronous Reference Controller (SRF) controller. This SRF controller generates the optimized pulses with the use of the CPWM approach. The proposed system has the advantage of very low THD after adding the UPQC with the inductive transformer. The remaining paper is structured as follows. Section II presents the proposed test system, Section III presents the equivalent circuit of the proposed UPQC structure, Section IV presents the proposed controller structure, Section V describes the results and the conclusions are drawn in Section VI.

**2. Inductive Hybrid UPQC Structure**

The basic inductive hybrid UPQC is depicted in Fig. 4. It consists of a UPQC with HSAPF and series Active Power Filter (APF), Inductive Filtering Transformer (IFT), load with medium power ratings and DG units [7]. The HSAPF and series APF are connected back to back and designed based on the neutral point clamped converter principle. The passive filter of HSAPF is a double resonant passive filter that has two resonant frequencies which can sustain more voltages. The passive filter of series APF is a low pass LCR filter. The IFT is a three winding transformer with YYD windings.

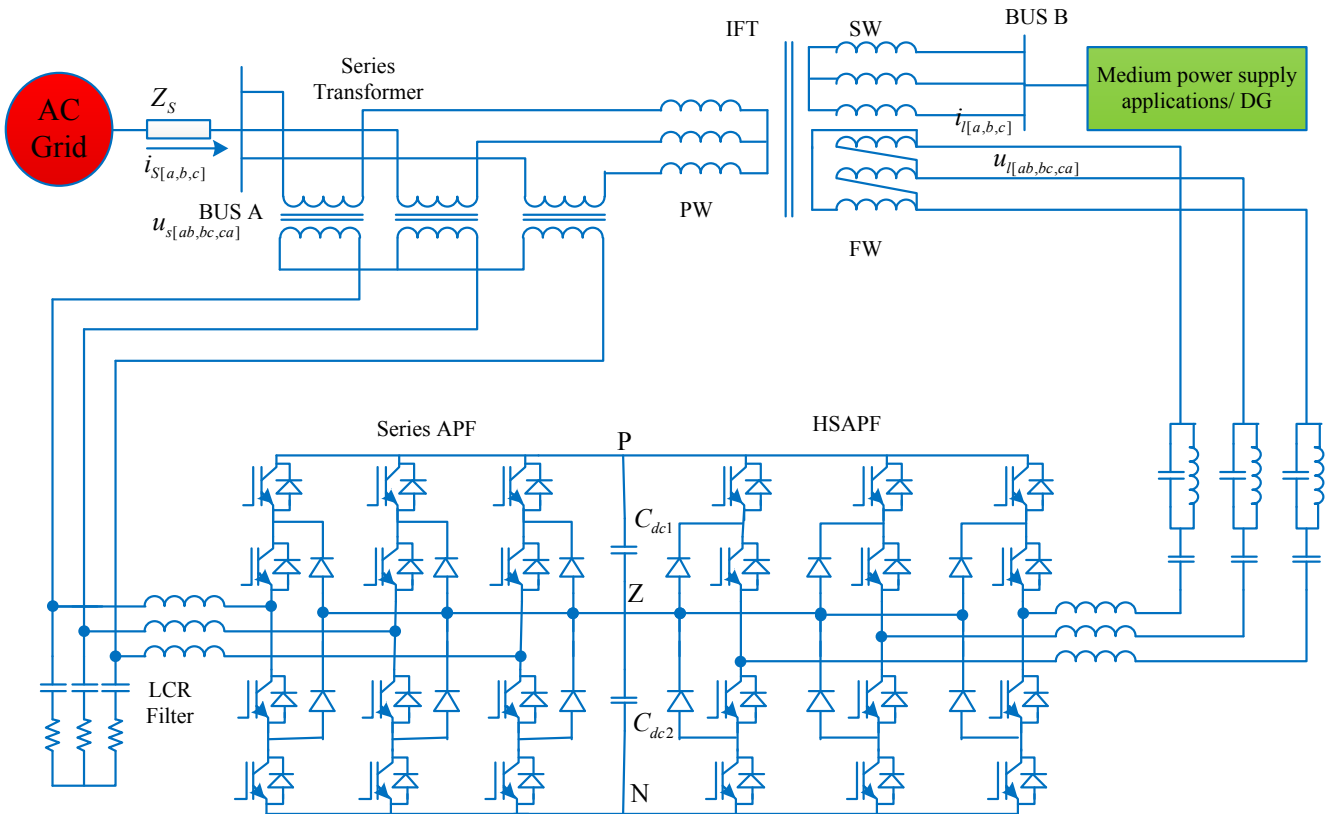

**Fig.4:** Test system with proposed inductive hybrid UPQC

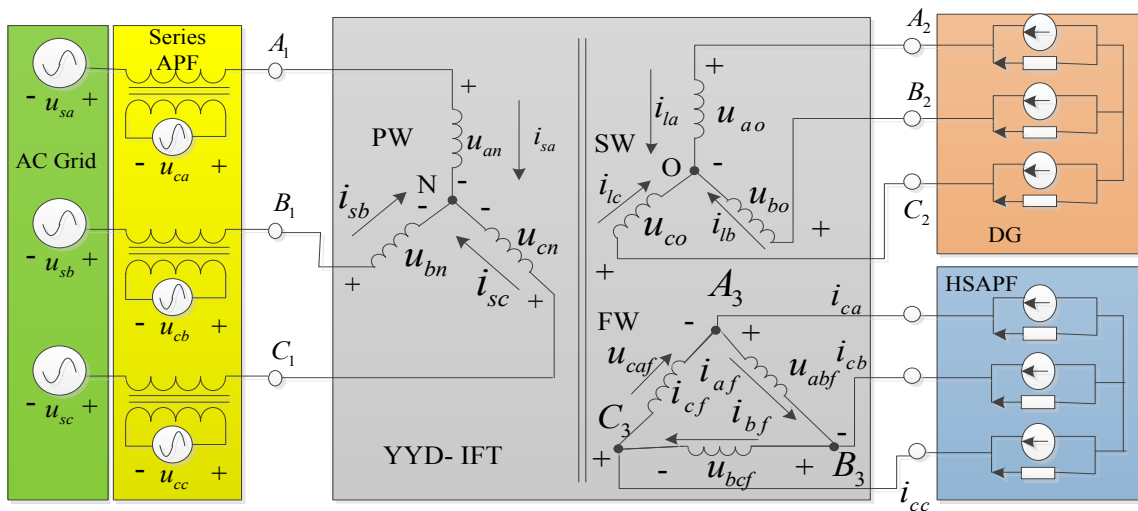

**Fig. 5:** Equivalent circuit of proposed UPQC arrangement

The primary winding of IFT is connected to the utility grid through the series transformer. The secondary winding of IFT is connected to the DG units or medium power application loads [8]. The third filter winding of IFT is connected to the HSAPF. The inductive filtering is achieved with the IFT and HSAPF. The parameters of the test system are shown in Table. I. When the harmonic magnetic balance is achieved between the secondary winding and filtering winding, the harmonics in the secondary are compensated by the filtering winding which causes the reduction of harmonics in the primary of IFT. The benefit of this configuration is it compensates the harmonics well on the transformer and supplies the load reactive power demand.

**Table. I:** Parameters of the test system

Parameter	Value
Grid	10kV
Series Transformer	5.77kV/0.23kV
Frequency	50 Hz
DC Capacitor	9450 μF
DC Reference voltage	800 V
Filter Transformer	
Winding type	YYD
Primary winding voltage	5.77kV
Secondary winding voltage	0.23 kV
Filter winding voltage	0.4 kV
Rating of YYD Transformer	630 kVA

### 3. Proposed Control Mechanism

#### 3.1 Equivalent circuit model

The circuit equivalent model of the proposed test approach is shown in Fig. 5. It is assumed that the DG is assumed as non sinusoidal current source with impedance parallel. The HSAPF is treated as non sinusoidal source current type in shunt with impedance [9]. The series filter is treated as a controllable voltage source. The equivalent impedance of three windings PW, SW and FW are  $Z_1$ ,  $Z_2$  and  $Z_3$  respectively. The hybrid UPQC is installed between grid and DG with three windings, the proposed series transformer and IFT are step-down transformers.

#### 3.2 Current harmonic control

This section describes the detailed analysis of the harmonic current compensation mechanism. The function of HSAPF is to compensate for the current harmonics and to make the load currents free from harmonics. From the magnetic balance principle of the transformer, the currents in three winding of transformer are (1)

$$\begin{cases} N_{i1}i_{sa} + N_{i2}i_{1a} + N_{i3}i_{af} = 0 \\ N_{i1}i_{sb} + N_{i2}i_{1b} + N_{i3}i_{bf} = 0 \\ N_{i1}i_{sc} + N_{i2}i_{1c} + N_{i3}i_{cf} = 0 \end{cases} \quad (1)$$

Voltage signal equations of multiple winding based transformer are (2)

$$\begin{cases} V_{an1} - \frac{N_{i1}}{N_{i3}}V_{abf} = i_{sa}Z_1 - \frac{N_{i1}}{N_{i3}}i_{af}Z_3 \\ V_{bn1} - \frac{N_{i1}}{N_{i3}}V_{bcf} = i_{sb}Z_1 - \frac{N_{i1}}{N_{i3}}i_{bf}Z_3 \\ V_{cn1} - \frac{N_{i1}}{N_{i3}}V_{caf} = i_{sc}Z_1 - \frac{N_{i1}}{N_{i3}}i_{cf}Z_3 \end{cases} \quad (2)$$

As per the Kirchhoff current law, the current in filter winding is described in (3)

$$\begin{cases} V_{abf} = i_{zb}Z_{ob} - i_{za}Z_{oa} = (i_{zb} - i_{za})Z_o \\ V_{bcf} = i_{zc}Z_{oc} - i_{zb}Z_{ob} = (i_{zc} - i_{zb})Z_o \\ V_{caf} = i_{za}Z_{oa} - i_{zc}Z_{oc} = (i_{za} - i_{zc})Z_o \end{cases} \quad (3)$$

The voltage equations of filter winding are described as (4)

$$\begin{cases} i_{sa} + i_{sb} + i_{sc} = 0 \\ i_{1a} + i_{1b} + i_{1c} = 0 \\ i_{af} + i_{bf} + i_{fc} = 0 \\ i_{af} = i_{cf} + i_{ca} \\ i_{bf} = i_{af} + i_{cb} \\ i_{cf} = i_{bf} + i_{cc} \end{cases} \quad (4)$$

From equations (1)-(4), the grid currents are obtained as (5)

$$\begin{cases} i_{sa} = \frac{V_{an1} - \frac{N_{i1}}{N_{i3}}(i_{ra} - i_{rb})Z_0 - \frac{N_{i1}N_{i2}}{N_{i3}^2}(Z_3 + 3Z_0)i_{1a}}{Z_1 + \frac{N_{i1}^2}{N_{i3}^2}(Z_3 + 3Z_0)} \\ i_{sb} = \frac{V_{bn1} - \frac{N_{i1}}{N_{i3}}(i_{rb} - i_{rc})Z_0 - \frac{N_{i1}N_{i2}}{N_{i3}^2}(Z_3 + 3Z_0)i_{1b}}{Z_1 + \frac{N_{i1}^2}{N_{i3}^2}(Z_3 + 3Z_0)} \\ i_{sc} = \frac{V_{cn1} - \frac{N_{i1}}{N_{i3}}(i_{rc} - i_{ra})Z_0 - \frac{N_{i1}N_{i2}}{N_{i3}^2}(Z_3 + 3Z_0)i_{1c}}{Z_1 + \frac{N_{i1}^2}{N_{i3}^2}(Z_3 + 3Z_0)} \end{cases} \quad (5)$$

From equation (5), the grid currents are majorly affected by currents of HSAPF, load currents, primary voltages and grid currents. Assume the primary voltages are completely compensated and the current has no harmonics, then the HSAPF reference currents should meet equation (6)

$$\begin{cases} i_{ra} = \frac{N_{i2}}{N_{i3}} \frac{(Z_3 + 3Z_0)}{3Z_0} (i_{1c} - i_{1a}) \\ i_{rb} = \frac{N_{i2}}{N_{i3}} \frac{(Z_3 + 3Z_0)}{3Z_0} (i_{1a} - i_{1b}) \\ i_{rc} = \frac{N_{i2}}{N_{i3}} \frac{(Z_3 + 3Z_0)}{3Z_0} (i_{1c} - i_{1c}) \end{cases} \quad (6)$$

$$\begin{cases} V_{an1} = V_{sa} + \frac{N_1}{N_2} V_{ca} \\ V_{bn1} = V_{sb} + \frac{N_1}{N_2} V_{cb} \\ V_{cn1} = V_{sc} + \frac{N_1}{N_2} V_{cc} \end{cases} \quad (9)$$

To remove the effect of  $Z_3$  filter performance, this impedance is diagnosed in such a way it is close to zero. Hence, the reference currents are simplified as (7)

$$\begin{cases} i_{ra} = \frac{N_{i2}}{N_{i3}} (i_{1c} - i_{1a}) \\ i_{rb} = \frac{N_{i2}}{N_{i3}} (i_{1a} - i_{1b}) \\ i_{rc} = \frac{N_{i2}}{N_{i3}} (i_{1c} - i_{1c}) \end{cases} \quad (7)$$

From (8) and (9), if the primary voltages have deviated from the normal values, the reference voltages are (10)

$$\begin{cases} V_{cra} = \left( \frac{N_{i1}}{N_{i2}} V_{La}^* - V_{sa} \right) \frac{N_2}{N_1} \\ V_{crb} = \left( \frac{N_{i1}}{N_{i2}} V_{Lb}^* - V_{sb} \right) \frac{N_2}{N_1} \\ V_{crc} = \left( \frac{N_{i1}}{N_{i2}} V_{Lc}^* - V_{sc} \right) \frac{N_2}{N_1} \end{cases} \quad (10)$$

### 3.3 Voltage harmonic control

The series APF controls the voltages and is responsible for harmonic less sinusoidal voltages with suitable amplitudes [10]. By controlling the secondary winding voltages of the IFT, the NLL voltages are controlled. Under no-load situations, the open circuit secondary voltages are presented as (8)

$$\begin{cases} V_{a0} = \frac{N_{i1}}{N_{i2}} V_{an1} \\ V_{b0} = \frac{N_{i1}}{N_{i2}} V_{bn1} \\ V_{c0} = \frac{N_{i1}}{N_{i2}} V_{cn1} \end{cases} \quad (8)$$

As per the faraday law and Kirchoff's voltage law, the primary voltages are written as (9)

## 4 Proposed Controller

The suggested hybrid UPQC is controlled with a synchronous reference controller. Here the HSAPF and series filter are independently controlled. The HSAPF compensates the current harmonics and regulates the DC link voltage. The series regulator compensates the load voltages.

### 4.1 Pre-filtering with SGDFT based PLL

Both series and shunt filters must be in association with utility. The conventional PLL provides weak achievement under non ideal voltage signals, hence in this paper, a new pre-filter approach is introduced which uses SGDFT. The basic controller structure of SGDFT filter-based PLL is depicted in Fig. 6. It has three main parts they are positive sequence components separation, voltage normalization and SRF PLL [11]. The voltage normalization technique is provided to eliminate the achievement of changing input signals on synchronous reference PLL. The realization of SGDFT based filter is shown in Fig. 7. This SGDFT based filter removes the serious deviations in voltages efficiently as the PI controller is tuned properly.

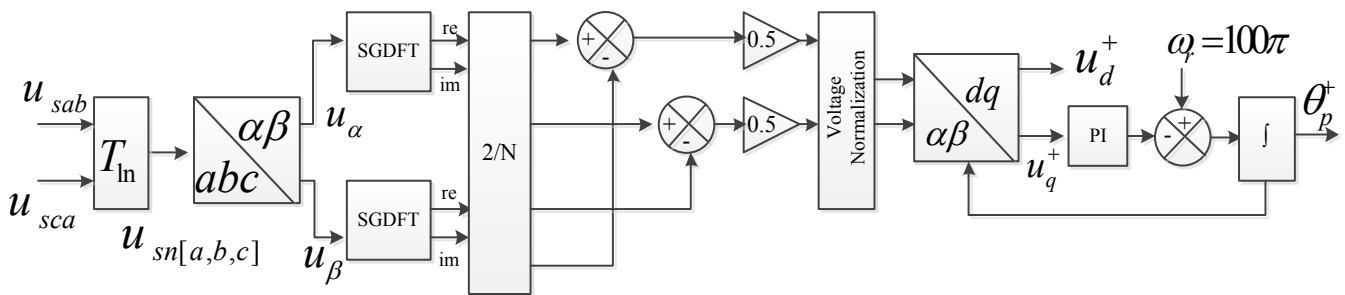

Fig.6: SGDFT based SRF controller